

FEATURES

- 420 - 450 MHz
- Amplitude Tracking ± 0.25 dB Port/Port
- Phase Tracking $\pm 3^\circ$ Max
- Isolation (Input/Output, 111 dB)



**MODEL NO.
100D9106**

**Switch / Attenuator /
Phase Shifter**

MFD

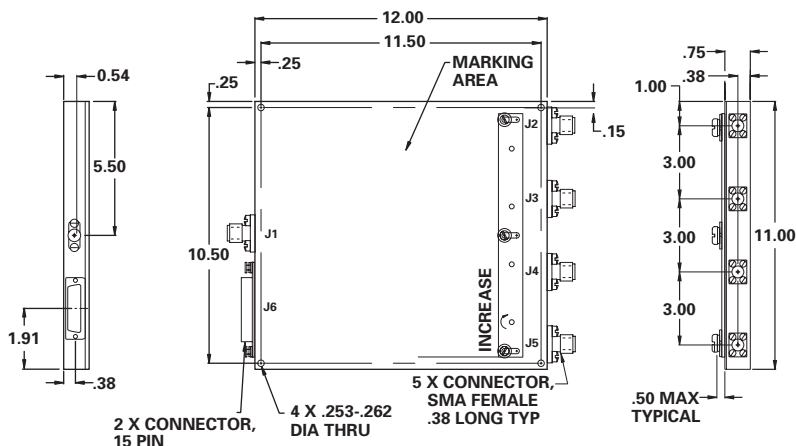

.xx = .02
.xxx = .010

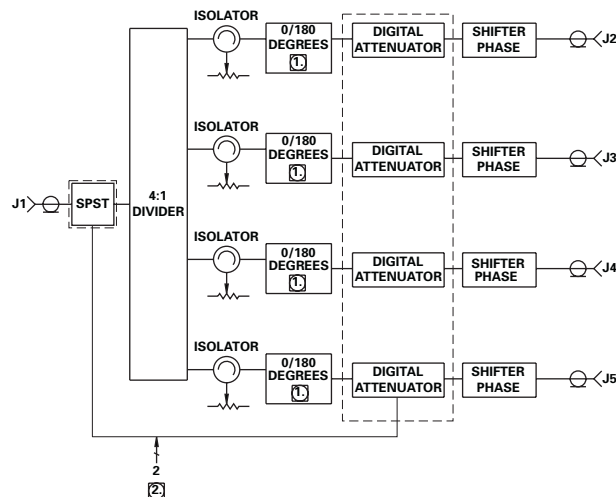

GUARANTEED PERFORMANCE

Parameter	Min	Typ	Max	Units	Conditions
Operating Frequency	420		450	MHz	
DC Current		150	200	mA	At +15 VDC Supply
Control Type					
Control Current	High			μ A	$V_{IH} = +2.7$ V
	Low		11	μ A	$V_{IL} = +0.5$ V
Insertion Loss		10		dB	Excluding 3 dB
Isolation	90	111		dB	In / Out
	40	65		dB	Out / Out
VSWR		1.0/1	1.3/1		
Impedance		50		OHMS	
Switching Speed			1	μ Sec	50% TTL to 90% / 10% RF
Transition (Rise/Fall) Time				nSec	90% / 10% or 10% / 90% RF
Switching (Video) Transients				V	Peak Value
Intercept Points				dBm	
	2nd			dBm	
	3rd			dBm	
RF Power	Operate	+13		dBm	
	No Damage	+16		dBm	
Operating Temperature	+15		+50	$^\circ$ C	TA