

FEATURES

- 350 - 450 MHz
- 1.7 dB Insertion Loss
- 55 dB Isolation
- 6 Line Encoded TTL Control
- Constant Phase
- Bite Circuitry
- SMA Connectors



**MODEL NO.
DSWM9040**

PIN Diode Switch SP40T

HDI

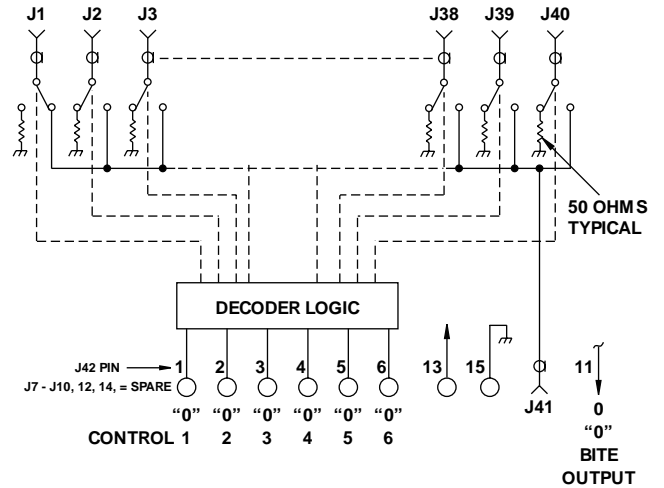
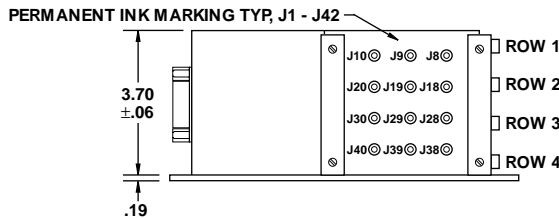
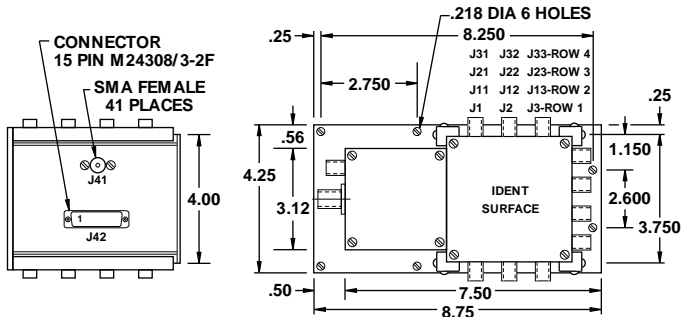

GUARANTEED PERFORMANCE

Parameter	Min	Typ	Max	Units	Conditions
Operating Frequency	350		450	MHz	
DC Current			120	mA	At +5 VDC Supply
Control Type		TTL			6 Line, See Control Table
Bite Circuitry		TTL			Logic "1" = Failure Output goes high within 1.5 μSec of Failure
Control Current	High Low	1 1	±10 ±10	μA	V _{IH} = +2.7 V V _{IL} = +0.5 V
Insertion Loss		1.7	3.0	dB	
Insertion Loss Flatness			±0.5	dB	
Insertion Loss Stability			0.3	dB	Over Temperature
Insertion Loss Matching			±0.3	dB	370 - 450 MHz
Insertion Phase Ripple			±2.0	DEG	From Linear
Insertion Phase Stability			±2.0	DEG	Over Temperature
Insertion Phase Matching			±0.5	DEG	370 - 450 MHz
Isolation	45	55		dB	Between Outputs
VSWR	Thru Termination	1.15	1.3/1 1.3/1		
Impedance		50		OHMS	
Switching Speed		4	5	μSec	50% TTL to 10% / 90% RF
Transition (Rise/Fall) Time		1.5		μSec	10% / 90% to 90% / 10% RF
RF Power	Operate No Damage		+20	dBm	0.1 dB Compression
Operating Temperature	-15	+25	+70	°C	TA

