

## FEATURES

- Total Integration of GaAs MMIC Attenuators, Silicon MMIC Amplifiers, and TTL Drivers
- Ultra Small 1.3 x 1.5 Surface Mount Package
- Phase and Amplitude Balance Channel to Channel

HDI

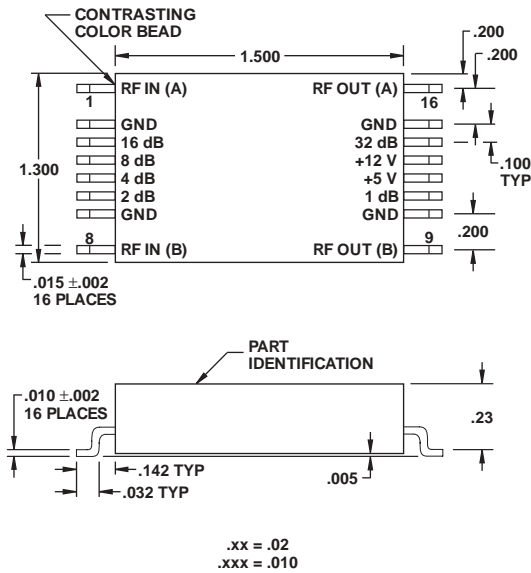

MODEL NO.  
DA0900

Dual Attenuator / Amplifier

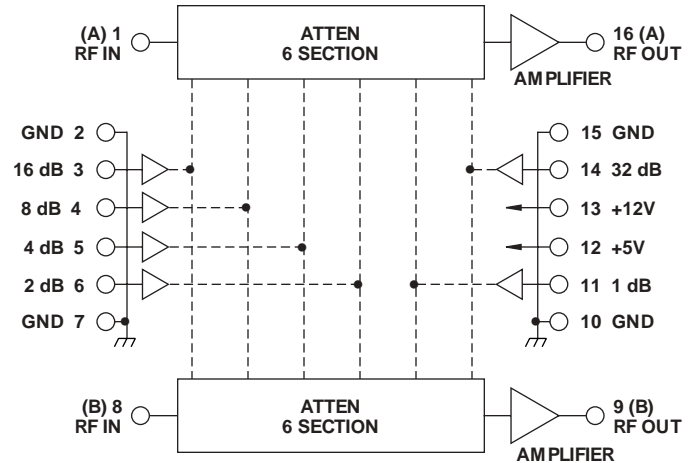

## GUARANTEED PERFORMANCE

Parameter	Min	Typ	Max	Units	Conditions
Operating Frequency	20		300	MHz	
DC Current		3	10	mA	At +5 VDC Supply
		34	50	mA	At +12 VDC Supply
Control Type		TTL			6 Line Logic "0" = Thru Logic "1" = Attenuation
Control Current	High	0	±40	µA	VIH = +2.7V
	Low	0	±40	µA	VIL = +0.5V
Insertion Gain	14	16	20	dB	
Noise Figure		7	10	dB	
Isolation	Channel to Channel	60	66	dB	20 - 100 MHz
		40	54	dB	100 - 300 MHz
Phase Vs. Attenuation		±6	±10	DEG	Channel to Channel
	Balance	±2	±5	DEG	
Attenuation	LSB	0	1	dB	1, 2, 4, 8, 16, 32 ±(0.25 dB ±2% of Atten. Setting in dB) Channel to Channel
	Range		63	dB	
	Accuracy			dB	
	Balance		0.2	±0.5	dB
VSWR		1.2/1	1.4/1		
Impedance		50		OHMS	
Switching Speed		36	50	nSec	50% TTL to 90% / 10% RF
Transition (Rise/Fall) Time		20		nSec	90% / 10% or 10% / 90% RF
RF Power	Operate	+5	+0	dBm	0.1 dB Compression
	No Damage		+20	dBm	
Operating Temperature	-55	+25	+85	°C	TA

