

**Features**

- Built-in zener Di between collector gate VCL typ. 400V
- Built-in gate protection diode
- SMD PKG TO252
- Low saturated voltage  
VCE(sat) Max. 1.4V (at VGE=10V, IC=5A)

**Package**

TO252



**Applications**

- Ignitor

**Equivalent circuit**

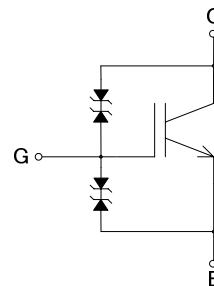

**Absolute maximum ratings**

(Ta=25°C)

Characteristic	Symbol	Rating	Unit
Collector to Emitter Voltage	VCES	CLAMPED	V
Gate to Emitter Voltage	VGE	±20	V
Continuous Collector Current	IC(DC)	15	A
Maximum Allowable Power Dissipation	PC	55 (Tc=25°C)	W
Operating Junction Temperature	Tj	150	°C
Storage Temperature	Tstg	-55 to +150	°C

The information included herein is believed to be accurate and reliable. However, SANKEN ELECTRIC CO., LTD assumes no responsibility for its use ; nor for any infringements of patents or other rights of third parties that may result from its use.

**Electrical characteristics**

(Ta=25°C)

Characteristic	Symbol	Test Conditions	Limits			Unit
			MIN.	TYP.	MAX.	
Collector to Emitter Breakdown Voltage	V(BR)CES	IC= 2mA, VGE=0V	375	400	425	V
Gate to Emitter Breakdown Voltage	V(BR)GES	IG=±100μA, VCE=0V	±20			V
Emitter to Collector Breakdown Voltage	V(BR)ECS	IEC=10mA, VGE=0V	20			V
Collector to Emitter Leakage Current	ICES	VCE=300V, VGE=0V			100	μA
Gate to Emitter Leakage Curren	IGES	VGE=±20V, VCE=0V			±100	μA
Gate Threshold Voltage	VGE(th)	VCE= 10V, IC=1mA	1.4	1.8	2.2	V
Collector to Emitter Saturation Voltage	VCE(sat)	VGE=4.5V, IC= 5A		1.2	1.5	V
Collector to Emitter Saturation Voltage	VCE(sat)	VGE=10V, IC= 5A		1.1	1.4	V
Collector to Emitter Saturation Voltage	VCE(sat)	VGE=10V, IC= 10A		1.4	1.7	V
Input Capacitance	Cies	VCE=10V f=1.0MHz VGE=0V		700		pF
Output Capacitance	Coes			300		
Reverse Transfer Capacitance	Cres			220		
Self Clamped Inductive Switching Energy	ES/B	L=5mH, Rg=200Ω	150			mJ

The information included herein is believed to be accurate and reliable. However, SANKEN ELECTRIC CO., LTD assumes no responsibility for its use ; nor for any infringements of patents or other rights of third parties that may result from its use.

**Characteristic Curves (Tc=25°C)**

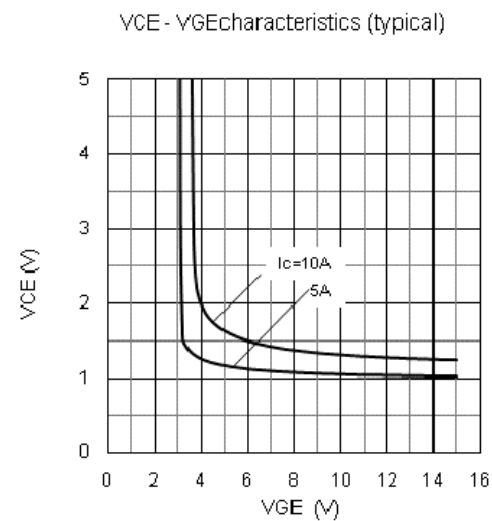
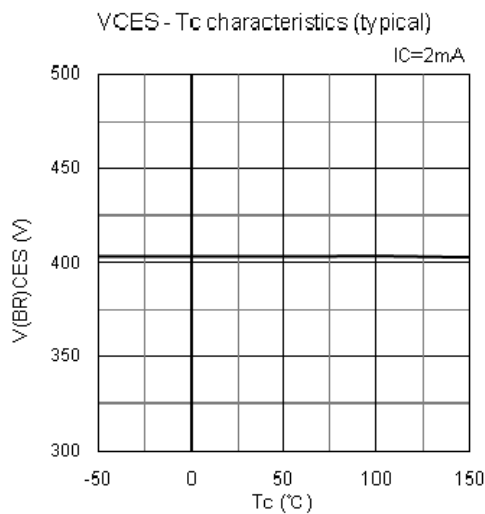
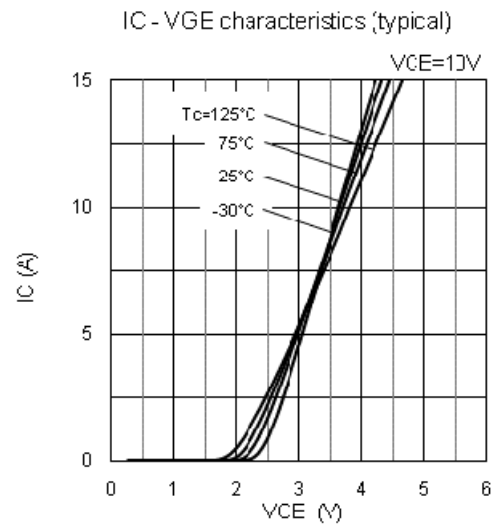
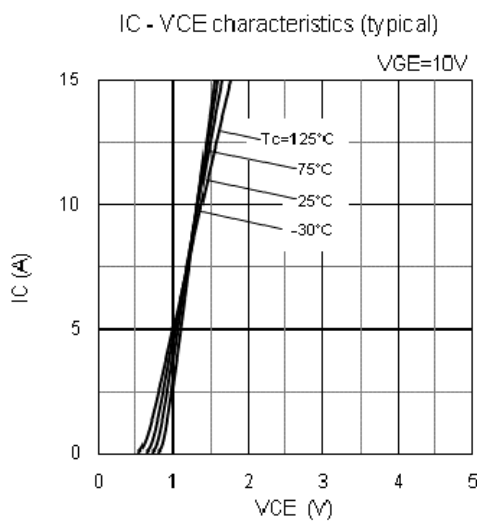
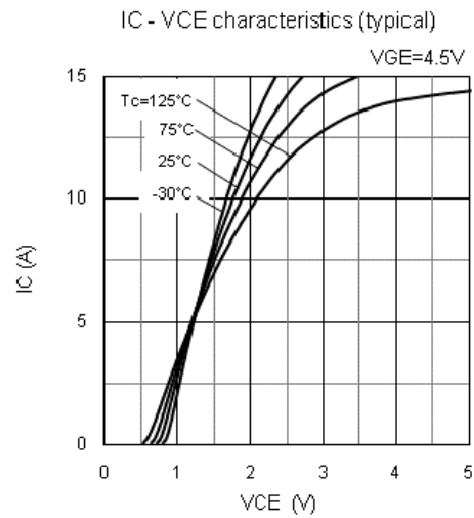
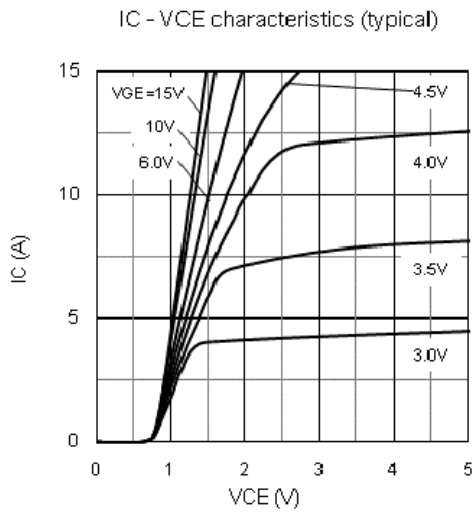

The information included herein is believed to be accurate and reliable. However, SANKEN ELECTRIC CO., LTD assumes no responsibility for its use ; nor for any infringements of patents or other rights of third parties that may result from its use.

**Characteristic Curves (Tc=25°C)**

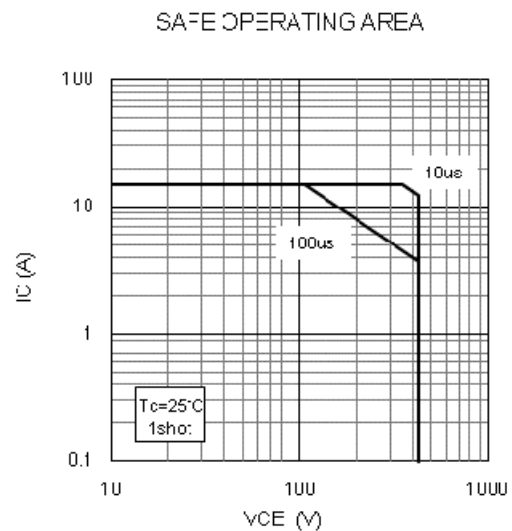
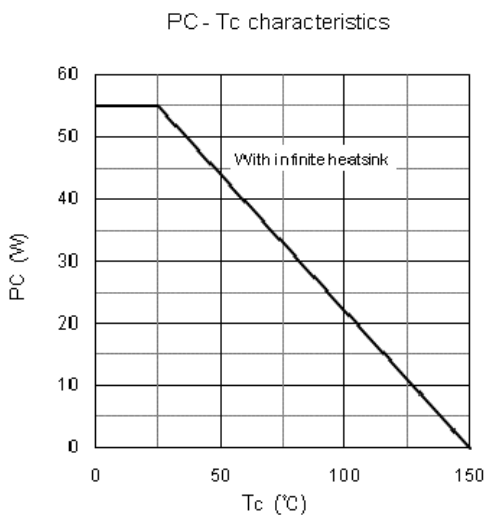
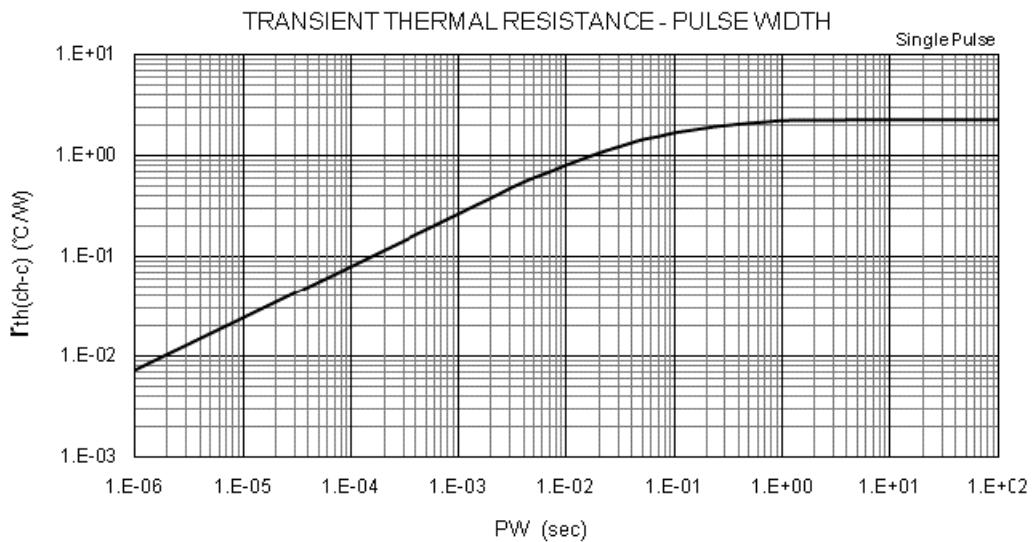
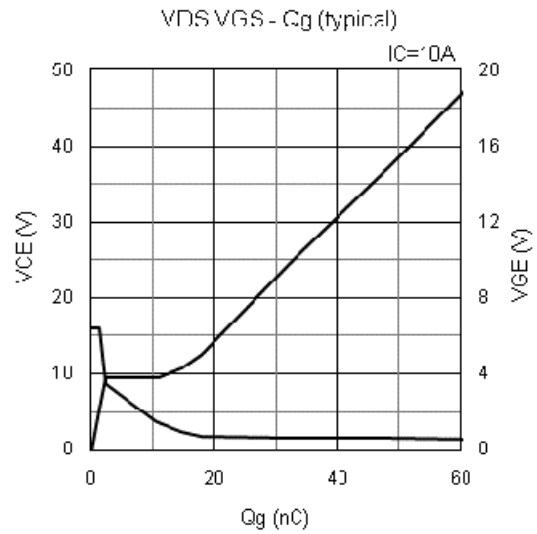
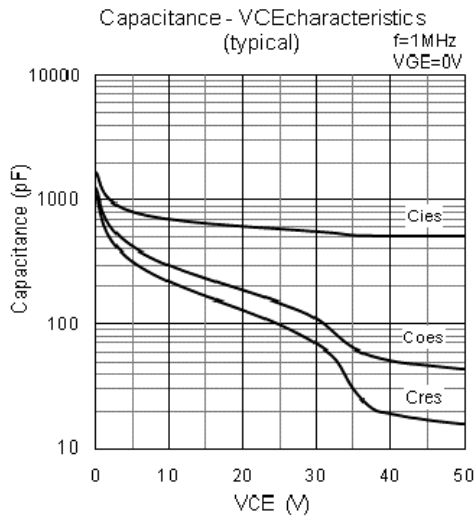

The information included herein is believed to be accurate and reliable. However, SANKEN ELECTRIC CO., LTD assumes no responsibility for its use ; nor for any infringements of patents or other rights of third parties that may result from its use.

**Outline**

TO252

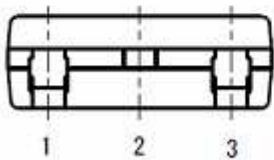
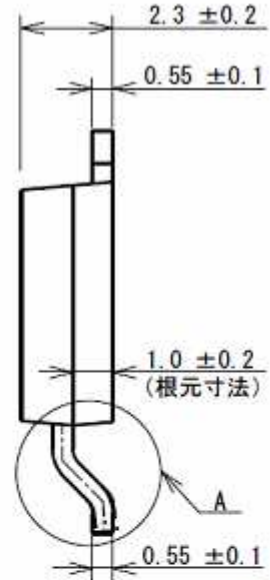
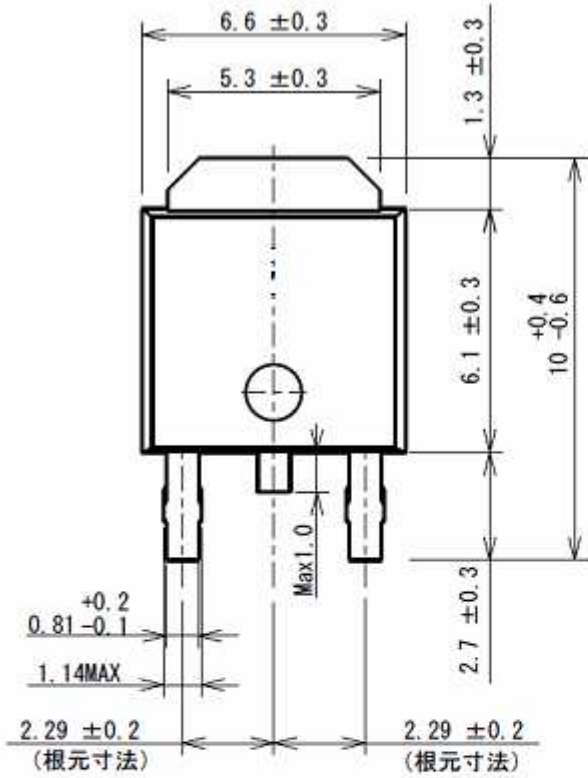

Pin assignment

- (1) Gate
- (2) Drain
- (3) Source

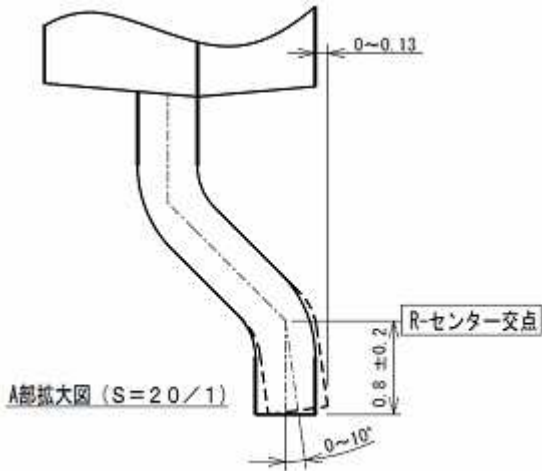
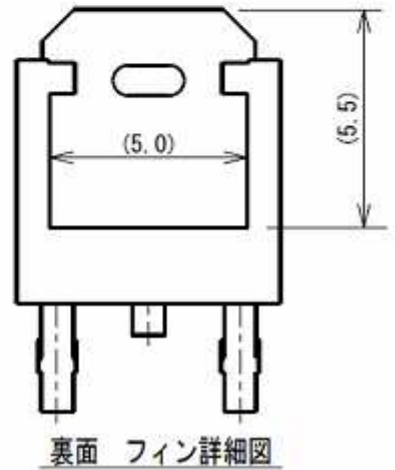

Weight Approx.0.33g