

SN8200

Wi-Fi Network Controller Module

User Manual And Datasheet

Version: 1.2

May 30, 2013

Note: SyChip, LLC. reserves the right to make changes in specifications at any time and without notice. The information furnished in this data sheet is believed to be accurate and reliable. However, no responsibility is assumed by SyChip for its use, nor any infringements of patents or other rights of third parties resulting from its use. No license is generated under any rights of SyChip or its supporters unless specifically agreed.

Revision History

Revision	Date	Author	Change Description
0.1	12/09/2012	Y. Fang	Initial version
0.5	02/03/2012	Y. Fang	Preliminary version
0.6	2/20/2012	N. Nagayama	Update performance data and adjusted table format
0.7	04/20/2012	J. Gregus	Update CE compliance information
1.0	08/27/2012	Y. Fang	Formal Release
1.1	01/23/2013	Y. Fang	Added Power Rail Current Specification and Standby Mode Current Consumption
1.2	05/30/2013	R. Willett	Changed specs in Table 1 for Pin 2, 3, 4, and 30

Table of Contents

1	SYSTEM DESCRIPTIONS	6
1.1	APPLICATIONS	6
1.2	MODULE SUMMARY	6
1.3	BLOCK DIAGRAM	7
1.4	ACRONYMS.....	7
2	MECHANICAL SPECIFICATIONS	8
2.1	MODULE DIMENSION	8
2.2	MODULE TOP AND SIDE VIEW	8
2.3	MODULE FOOTPRINT (TOP VIEW)	9
2.4	MODULE PIN-OUT.....	10
3	DC ELECTRICAL SPECIFICATIONS	13
3.1	TYPICAL POWER CONSUMPTION.....	13
4	RF SPECIFICATIONS	14
4.1	DC/RF CHARACTERISTICS FOR IEEE 802.11B	14
4.2	DC/RF CHARACTERISTICS FOR IEEE 802.11G.....	15
4.3	DC/RF CHARACTERISTICS FOR IEEE 802.11N.....	16
5	ENVIRONMENTAL SPECIFICATIONS	17
5.1	ABSOLUTE MAXIMUM RATINGS	17
5.2	RECOMMENDED OPERATING CONDITIONS.....	17
6	APPLICATION INFORMATION	18
6.1	EXTERNAL DIGITAL INTERFACES	18
6.1.1	<i>Reference connection for UART host interface</i>	18
6.1.2	<i>Reference connection for the SPI host interface</i>	19
6.2	RECOMMENDED HOST (CUSTOMER) CIRCUIT BOARD PCB PATTERN	20
6.3	HOST PCB LAYOUT RECOMMENDATIONS	20
6.4	MODULE LOCATION	21
6.4.1	<i>Location in x-y plane</i>	22
6.4.2	<i>Location in z-plane</i>	22
7	ASSEMBLY INFORMATION	23
7.1	LEAD-FREE SOLDERING REFLOW PROFILE.....	23
8	PACKAGING AND MARKING INFORMATION	24
8.1	CARRIER TAPE DIMENSIONS.....	24
8.2	MODULE MARKING INFORMATION	24
9	ORDERING INFORMATION	25
10	ROHS DECLARATION	25
11	REGULATORY INFORMATION	25
11.1	FCC NOTICE (USA)	25
11.2	FCC LABELING REQUIREMENTS	26
11.3	RF EXPOSURE.....	26
11.4	IC NOTICE (CANADA).....	26
11.5	IC LABELING REQUIREMENTS	27
11.6	CE NOTICE (EUROPE).....	27



Murata Wireless Solutions



11.7	CE LABELING REQUIREMENTS	27
12	TECHNICAL SUPPORT CONTACT	28
13	DISCLAIMER	28

LIST OF FIGURES

FIGURE 1 SN8200 MODULE BLOCK DIAGRAM 7

FIGURE 2 MODULE TOP AND SIDE VIEW 8

FIGURE 3 DETAILED MECHANICAL DATA (TOP VIEW) 9

FIGURE 4 UART HOST INTERFACE REFERENCE DIAGRAM 18

FIGURE 5 SPI HOST INTERFACE REFERENCE DIAGRAM 19

FIGURE 6 RECOMMENDED HOST (CUSTOMER) PCB PATTERN 20

FIGURE 7 RECOMMENDED HOST CIRCUIT BOARD DESIGN UNDERNEATH THE MODULE 21

FIGURE 8 RECOMMENDED LOCATIONS IN XY-PLANE 22

FIGURE 9 LOCATIONS NOT RECOMMENDED IN XY-PLANE 22

FIGURE 10 RECOMMENDED LOCATIONS IN Z-PLANE 22

FIGURE 11 LOCATIONS NOT RECOMMENDED IN XY-PLANE 22

FIGURE 12 REFLOW PROFILE PATTERN 23

FIGURE 13 CARRIER TAPE DIMENSIONS 24

FIGURE 14 MODULE MARKING DETAIL 24

LIST OF TABLES

TABLE 1 MODULE CONNECTOR SIGNAL DESCRIPTION 10

TABLE 2 TYPICAL POWER CONSUMPTION 13

TABLE 3 RF CHARACTERISTICS FOR IEEE 802.11B 14

TABLE 4 RF CHARACTERISTICS FOR IEEE 802.11G 15

TABLE 5 RF CHARACTERISTICS FOR IEEE 802.11N 16

TABLE 6 ABSOLUTE MAXIMUM RATING 17

TABLE 7 RECOMMENDED OPERATING CONDITIONS 17

TABLE 8 REFLOW PROFILE RECOMMENDATION 23

1 System Descriptions

1.1 Applications

SN8200 is a complete low power self-contained embedded wireless solution to address the connectivity demand in M2M applications. It integrates micro-controller, Wi-Fi BB/MAC/RF IC, RF front end, clocks, and on-board antenna into a small form factor module. SN8200 can be controlled by a host device through a serial interface; it can also serve as a standalone Wi-Fi station or network controller. Thus, it can be used to enable wireless connectivity to the simplest products with minimal engineering resources.

The SN8200 provides standard IEEE802.11 b/g/n functions. The integrated MCU supports Broadcom WICED™ software. It can be used for a variety of different applications, such as wireless sensor node, serial to Wi-Fi transceiver, Wi-Fi network controller, Wi-Fi gateway/bridges plus internet server.

When used in a system where the SN8200 is controlled by a host CPU, the serial host interface makes it very easy to integrate. When used in a system without a host CPU, the integrated ARM Cortex-M3 can be used to run a variety of applications.

The SN8200 Wi-Fi module can be used for Wi-Fi gateway if combined with other radio module. For example, one can design a Zigbee Wi-Fi gateway by combine SN8200 with SyChip SN3020 Zigbee module. SyChip provides a reference design to enable the OEM customer. This gateway design can be used for low cost and low power consumption applications like Home Area Networks.

1.2 Module Summary

- 2.4GHz IEEE 802.11b/g/n radio technology
- Dimension: 30.5 mm × 19.4 mm × 2.8 mm
- On-board antenna
- Transmit power: +18 dBm @ 11b /11Mbps
- Max receive sensitivity: -96dBm
- MCU: ARM Cortex-M3
- Diverse serial interface: UART, SPI
- Sensor applications support: ADC, DAC, I2C, GPIO
- Operating temperature range: -30°C to 85°C
- RoHS compliant
- MSL Level 3
- FCC/IC certified; CE compliant

1.3 Block Diagram

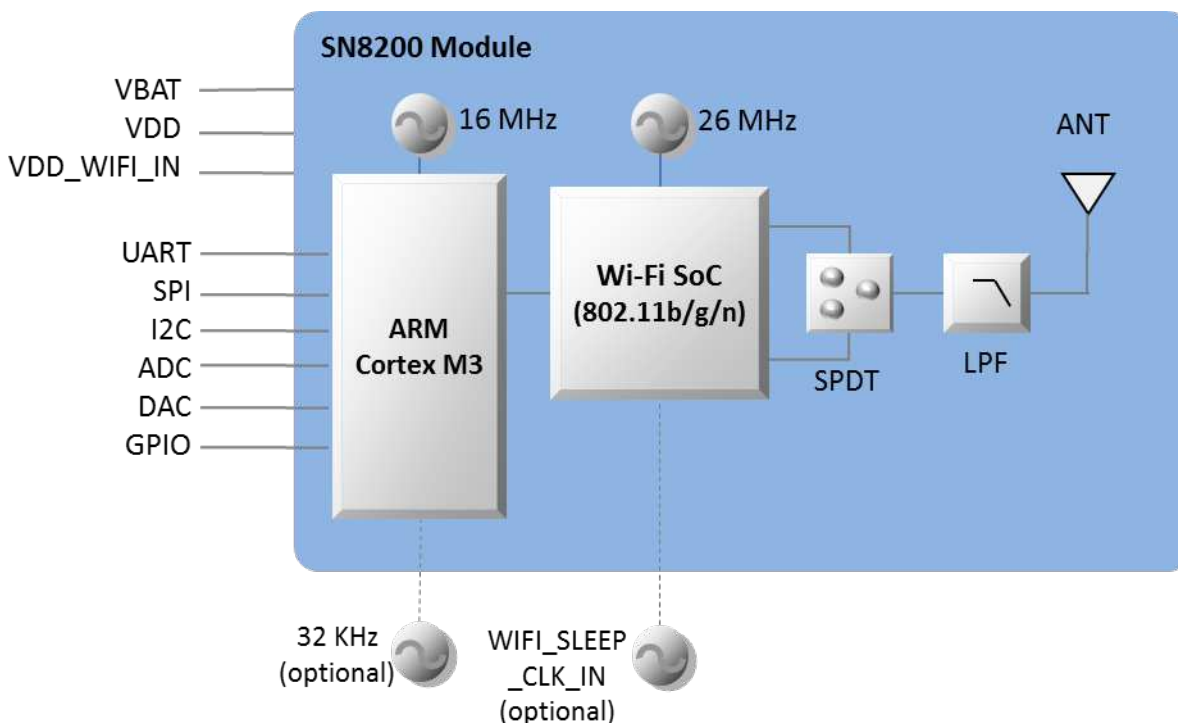

Figure 1 SN8200 Module Block Diagram

1.4 Acronyms

ADC	Analog to Digital Converter
GPIO	General-Purpose Input-Output
I2C	Intelligent Interface Controller
ISM	Industrial, Scientific and Medical
MAC	Medium Access Control
MSL	Moisture Sensitivity Level
PER	Packet Error Rate
ROHS	Restriction of Hazardous Substances
SPI	Serial Peripheral Interface
UART	Universal Asynchronous Receiver-Transmitter

2 Mechanical Specifications

2.1 Module dimension

Parameter	Typical	Units
Dimension (LxWxH)	30.5 x 19.4 x 2.8	mm
Dimension tolerances (LxWxH)	±0.2	mm

2.2 Module top and side view

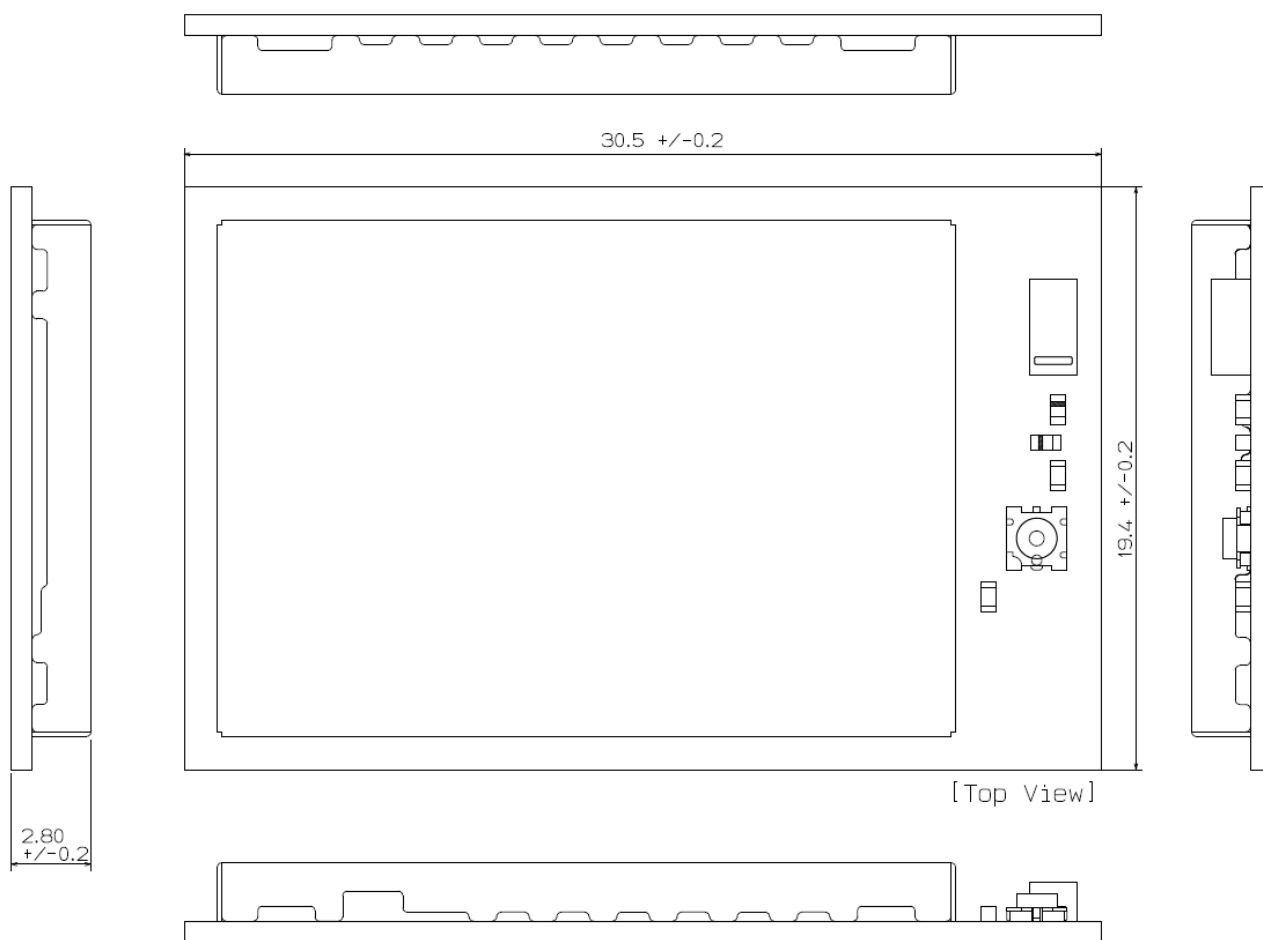

Figure 2 Module Top and Side View

2.3 Module footprint (top view)

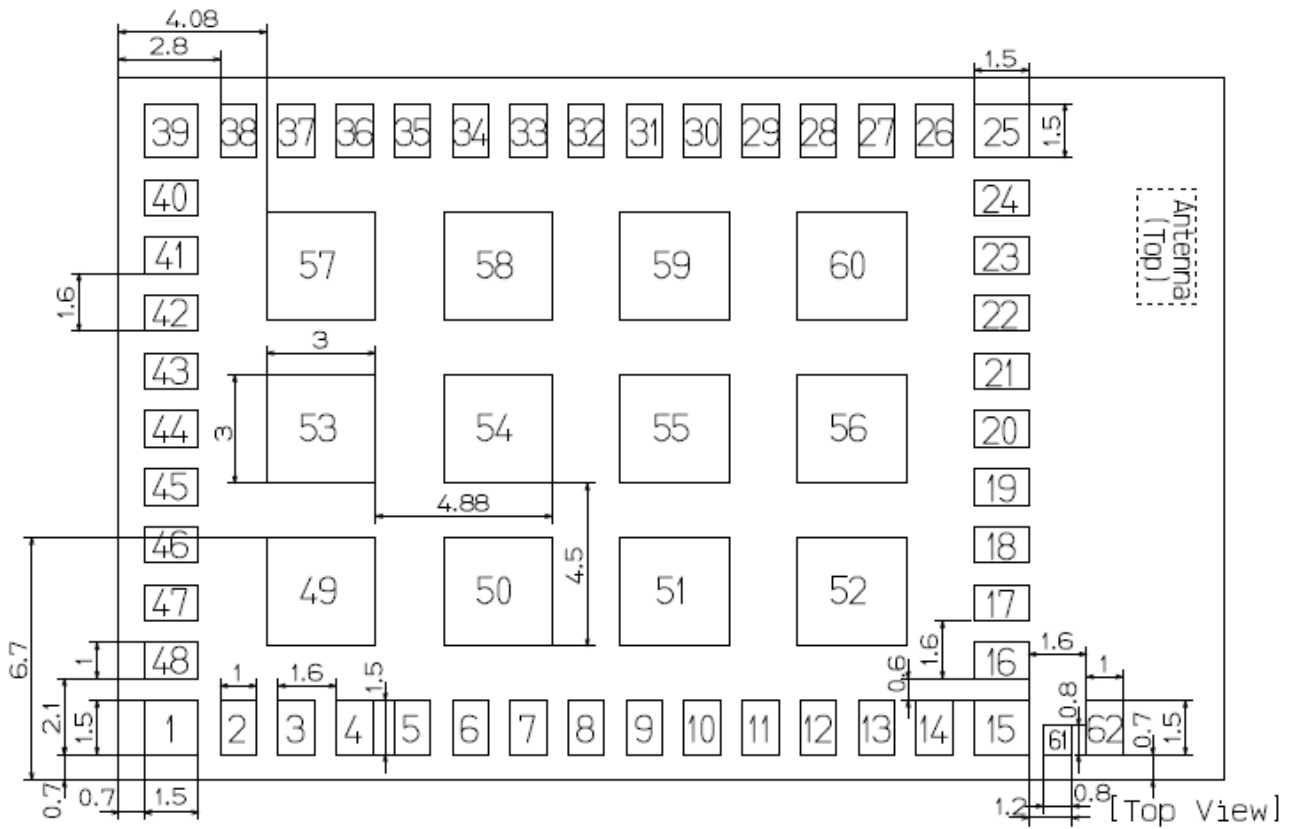

Figure 3 Detailed Mechanical Data (top view)

2.4 Module Pin-out

Table 1 Module Connector Signal Description

Pin #	Pin name	I/O	Description
1	GND	-	Ground
2	OSC32_IN	I/O	Optional precision 32.768 kHz slow clock input. No connect if not used
3	OSC32_OUT	I/O	No connect
4	WIFI_VDD_EN	I/O	No connect
5	ADC3	I/O	General purpose I/O or ADC3
6	ADC4	I/O	General purpose I/O or ADC4
7	ADC5	I/O	General purpose I/O or ADC5
8	VDD	PI	DC supply for MCU and I/O
9	ADC6	I/O	General purpose I/O or ADC6
10	DAC2	I/O	General purpose I/O or DAC2
11	DAC1	I/O	General purpose I/O or DAC1
12	ADC1	I/O	General purpose I/O or ADC1
13	Reserved	-	No connect
14	Reserved	-	No connect
15	GND	-	Ground
16	GND	-	Ground
17	GND	-	Ground
18	GND	-	Ground
19	GND	-	Ground
20	GND	-	Ground
21	GND	-	Ground
22	GND	-	Ground
23	GND	-	Ground
24	GND	-	Ground
25	GND	-	Ground
26	VDD_WIFI_IN	PI	Wi-Fi power supply
27	Reserved	-	No connect
28	Reserved	-	No connect
29	Reserved	-	No connect
30	WIFI_SLEEP_CLK_IN	I	Optional precision 32.768 kHz Wi-Fi sleep

Pin #	Pin name	I/O	Description
			clock input. Tie to GND if not used
31	GND	-	Ground
32	UART_TX	I/O	General purpose I/O or UART_TX
33	UART_RX	I/O	General purpose I/O or UART_RX
34	UART_CTS	I/O	General purpose I/O or UART_CTS
35	UART_RTS	I/O	General purpose I/O or UART_RTS
36	JTMS	I/O	General purpose I/O or JTMS
37	JTDI/SPI_NSS	I/O	General purpose I/O or JTDI or SPI_NSS
38	JTCK	I/O	General purpose I/O or JTCK
39	Ground	-	Ground
40	JTDO/SPI_SCK	I/O	General purpose I/O or JTDO or SPI_SCK
41	JTRST/SPI_MISO	I/O	General purpose I/O or JTRST or SPI_MISO
42	SPI_MOSI	I/O	General purpose I/O or SPI_MOSI
43	I2C_SCL	I/O	General purpose I/O or I2C_SCL
44	I2C_SDA	I/O	General purpose I/O or I2C_SDA
45	BOOT	-	Normal operation if connected to ground at power up.
46	ADC2	I/O	General purpose I/O or ADC2
47	MICRO_RST_N	I	Module reset
48	VBAT	PI	Power supply for backup circuitry when VDD is not present
49	GND	-	Ground
50	GND	-	Ground
51	GND	-	Ground
52	GND	-	Ground
53	GND	-	Ground
54	GND	-	Ground
55	GND	-	Ground
56	GND	-	Ground
57	GND	-	Ground
58	GND	-	Ground
59	GND	-	Ground
60	GND	-	Ground

Pin #	Pin name	I/O	Description
61	Reserved	-	No connect
62	GND	-	Ground

3 DC Electrical Specifications

3.1 Typical Power Consumption

Condition: 25C, includes both Wi-Fi chip and microcontroller

Table 2 Typical Power Consumption

Item		Condition	Values			Units
			Min	Typ	Max	
11b	Receive mode	11Mbps		110		mA
	Transmit mode (18dBm/ 100% Duty Cycle)			370		mA
11g	Receive mode	54Mbps		110		mA
	Transmit mode (14.5 dBm/ 100 % Duty Cycle)			290		mA
11n	Receive mode	MCS7		110		mA
	Transmit mode (13.5dBm/ 100% Duty Cycle)			280		mA
Standby Mode with IEEE802.11 Power Save		DTIM 1, Telnet session established and idling		3.15		mA
Standby Mode with IEEE802.11 Power Save		DTIM 3, Telnet session established and idling		1.28		mA

4 RF Specifications

4.1 DC/RF Characteristics for IEEE 802.11b

Conditions: 25deg.C, VDD_WIFI_IN=3.6V, VDD= 3.3V (11Mbps mode unless otherwise specified.)

Measured at 50Ω terminal load connected to the RF connector

Table 3 RF Characteristics for IEEE 802.11b

Parameters	Specification			
Modulation	DSSS/CCK			
Physical layer data rate	1,2,5.5,11Mbps			
RF Characteristics	Min	Typ.	Max.	Unit
Frequency range	2400	--	2483.5	MHz
Carrier frequency error	-20	--	+20	ppm
Transmit output power	16	18	20	dBm
Spectrum mask				
1 st side lobes	--	--	-30	dBr
2 nd side lobes	--	--	-50	dBr
Power-on and Power-down ramp	--	--	2	usec
RF Carrier Suppression	15	--	--	dBc
Modulation accuracy (EVM)	--	--	35	%
Outband spurious emissions				
30MHz to 1GHz (BW=100KHz)			-96	dBm
1GHz to 12.75GHz (BW=1MHz)			-41	dBm
1.8GHz to 1.9GHz (BW=1MHz)			-65	dBm
5.15GHz to 5.3GHz (BW=1MHz)			-85	dBm
Receive Minimum Sensitivity				
1Mbps (FER≤ 8%)	-94	-96	--	dBm
11Mbps (FER≤ 8%)	-86	-88	--	dBm
Maximum input level (FER≤ 8%)	-9.5	--	--	dBm
Adjacent channel rejection (FER≤ 8%)	35			dB

[Note]

1. Derate by 1.5 dB for temperatures less than -10C or more than 55C in transceiver mode.
2. Derate by 1.5 dB for temperatures less than -30C to -10C and 55C to 85C in receiver mode.

4.2 DC/RF Characteristics for IEEE 802.11g

Conditions: 25deg.C, VDD_WIFI_IN=3.6V, VDD= 3.3V (54Mbps mode unless otherwise specified.)

Measured at 50Ω terminal load connected to the RF connector

Table 4 RF Characteristics for IEEE 802.11g

Parameters	Specification			
Standard conformance	IEEE 802.11 g			
Modulation	OFDM			
Data rate	6, 9, 12, 18, 24, 36, 48, 54Mbps			
RF Characteristics	Min	Typ.	Max.	Unit
Frequency range	2400	--	2483.5	MHz
Carrier frequency error	-20	--	+20	ppm
Transmit output power	12.5	14.5	16.5	dBm
Spectrum mask				
9MHz to 11MHz (0dB ~ -20dB)	0		-	dB
11MHz to 20MHz (-20dB ~ -28dB)	0		-	dB
20MHz to 30MHz (-28dB ~ -40dB)	0		-	dB
30MHz to 33MHz (-40dB)	0		-	dB
Constellation Error (EVM)	--	--	-25	dB
Outband spurious emissions				
30MHz to 1GHz (BW=100KHz)			-96	dBm
1GHz to 12.75GHz (BW=1MHz)			-41	dBm
1.8GHz to 1.9GHz (BW=1MHz)			-65	dBm
5.15GHz to 5.3GHz (BW=1MHz)			-85	dBm
Received Minimum Sensitivity				
6Mbps (PER≤ 10%)	-87	-89	--	dBm
54Mbps (PER ≤ 10%)	-72	-74	--	dBm
Maximum input level (PER ≤ 10%)	-13	--	--	dBm
Adjacent channel rejection (PER ≤ 10%)	-1			dB

[Note]

1. Derate by 1.5 dB for temperatures less than -10C or more than 55C in transceiver mode.
2. Derate by 1.5 dB for temperatures less than -30C to -10C and 55C to 85C in receiver mode.

4.3 DC/RF Characteristics for IEEE 802.11n

Conditions: 25deg.C, VDD_WIFI_IN=3.6V, VDD= 3.3V (65Mbps mode unless otherwise specified.)

Measured at 50Ω terminal load connected to the RF connector

Table 5 RF Characteristics for IEEE 802.11n

Parameters	Specification			
Standard conformance	IEEE 802.11 n			
Modulation	OFDM			
Data rate	6.5, 13, 19.5, 26, 39, 52, 58.5, 65Mbps			
RF Characteristics	Min	Typ.	Max.	Unit
Frequency range	2400	--	2483.5	MHz
Carrier frequency error	-20	--	+20	Ppm
Power level	11	13	15	dBm
Spectrum mask				
9MHz to 11MHz (0dB ~ -20dB)	0		-	dB
11MHz to 20MHz (-20dB ~ -28dB)	0		-	dB
20MHz to 30MHz (-28dB ~ -45dB)	0		-	dB
30MHz to 33MHz (-45dB)	0		-	dB
Constellation Error (EVM)	--	--	-28	dB
Outband spurious emissions				
30MHz to 1GHz (BW=100KHz)			-96	dBm
1GHz to 12.75GHz (BW=1MHz)			-41	dBm
1.8GHz to 1.9GHz (BW=1MHz)			-65	dBm
5.15GHz to 5.3GHz (BW=1MHz)			-85	dBm
Received Minimum Sensitivity				
65Mbps (PER ≤ 10%)	-69	-71	--	dBm
Maximum input level (PER ≤ 10%)	-13			dB
Adjacent channel rejection (PER ≤ 10%)	-2			dB

[Note]

1. Derate by 1.5 dB for temperatures less than -10C or more than 55C in transceiver mode.
2. Derate by 1.5 dB for temperatures less than -30C to -10C and 55C to 85C in receiver mode.

5 Environmental Specifications

5.1 Absolute maximum ratings

Table 6 Absolute Maximum Rating

Symbol	Description	Min	Max	Unit
T _{op}	Operating temperature	-30	85	°C
T _{st}	Storage temperature	-40	85	°C
VDD	Power supply	0	4.0	V
VBAT	Power supply for backup circuitry when VDD is not present	0	4.0	V
VDD_WiFi	Wi-Fi Power supply	0	6.0	V
RFin	RF input power		0	dBm
MSL	Moisture Sensitivity Level	3		
RoHS	Restriction of Hazardous Substances	Compliant		

5.2 Recommended Operating Conditions

Table 7 Recommended Operating Conditions

	Min (V)	Typical (V)	Max (V)	Supply Current Specification (mA)
VDD	2.4	3.3	3.6	150
VBAT	2.0	3.3	3.6	10
VDD_WiFi	3.4	3.6	4.0	500

6 Application Information

6.1 External digital interfaces

6.1.1 Reference connection for UART host interface

Figure 4 illustrates the connections between SN8200 module and the host MCU via UART interface. A level shifter may be needed if the host UART interface level does not match with SN8200.

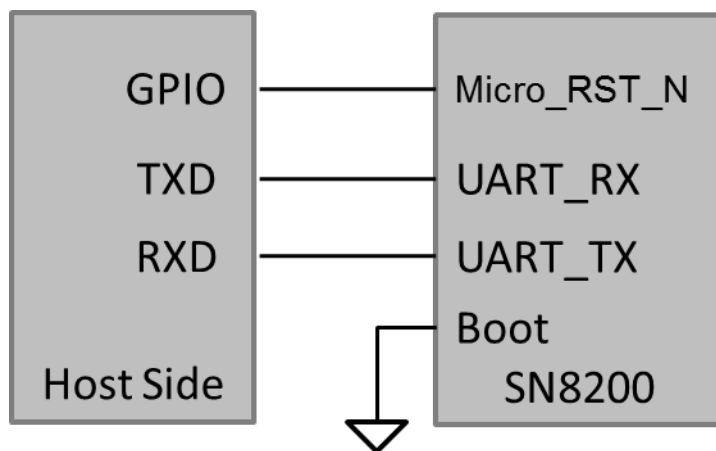

Figure 4 UART Host Interface Reference Diagram

6.1.2 Reference connection for the SPI host interface

Figure 5 illustrates the connections between SN8200 module and the host MCU via SPI interface.

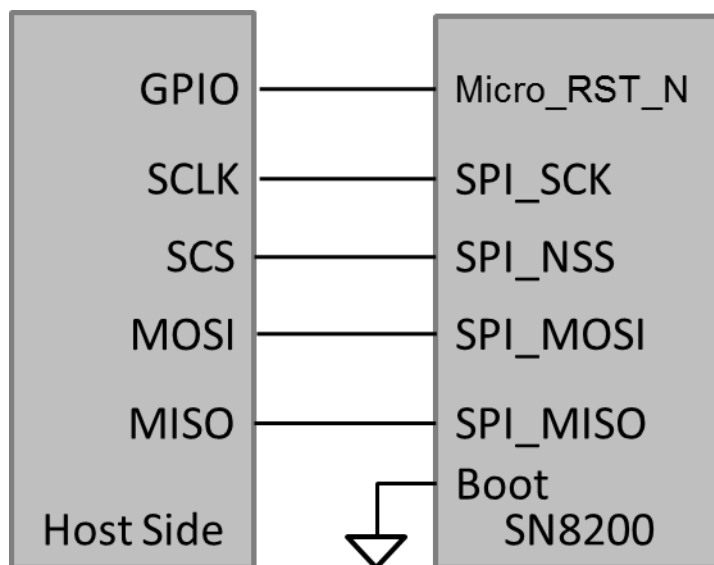

Figure 5 SPI Host Interface Reference Diagram

6.2 Recommended host (customer) circuit board PCB pattern

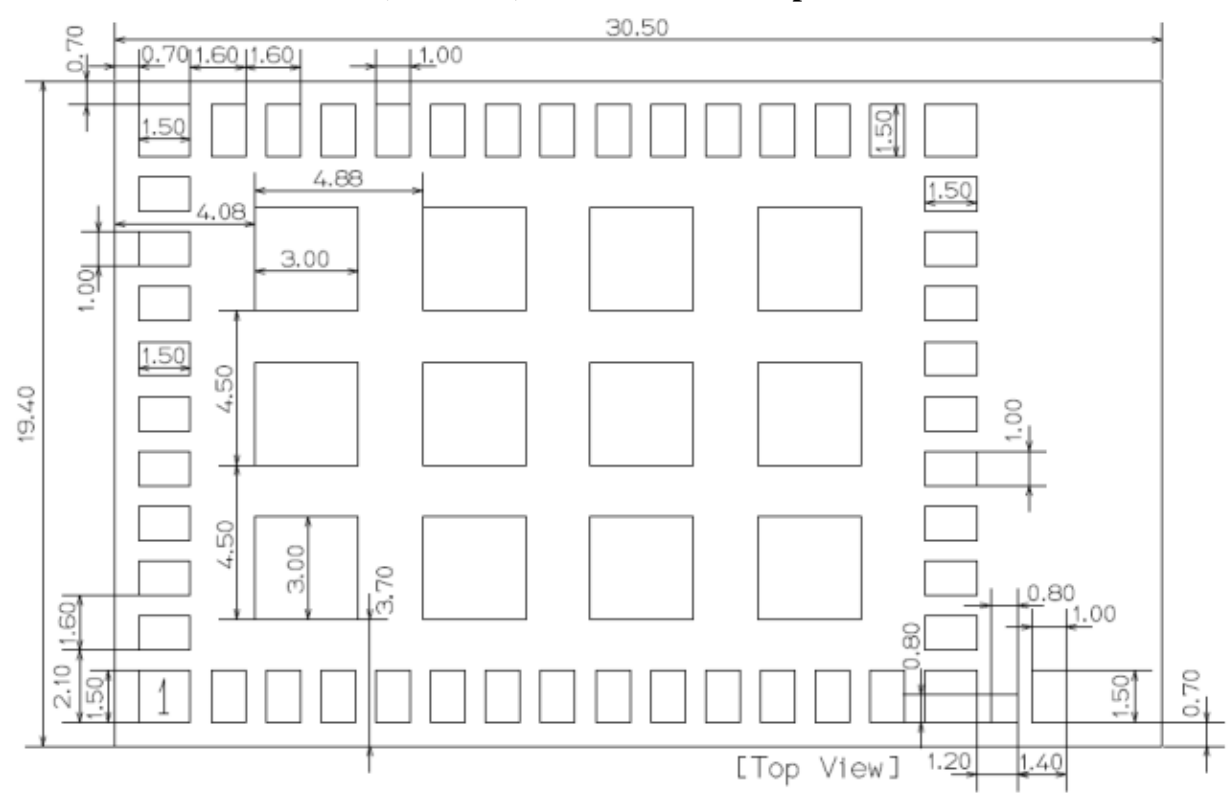

Figure 6 Recommended Host (customer) PCB Pattern

6.3 Host PCB layout recommendations

The SN8200 module has an onboard antenna therefore it requires careful host PCB layout underneath the module such that the radio can achieve its best RF performance. Refer to Figure 7 for the requirements.

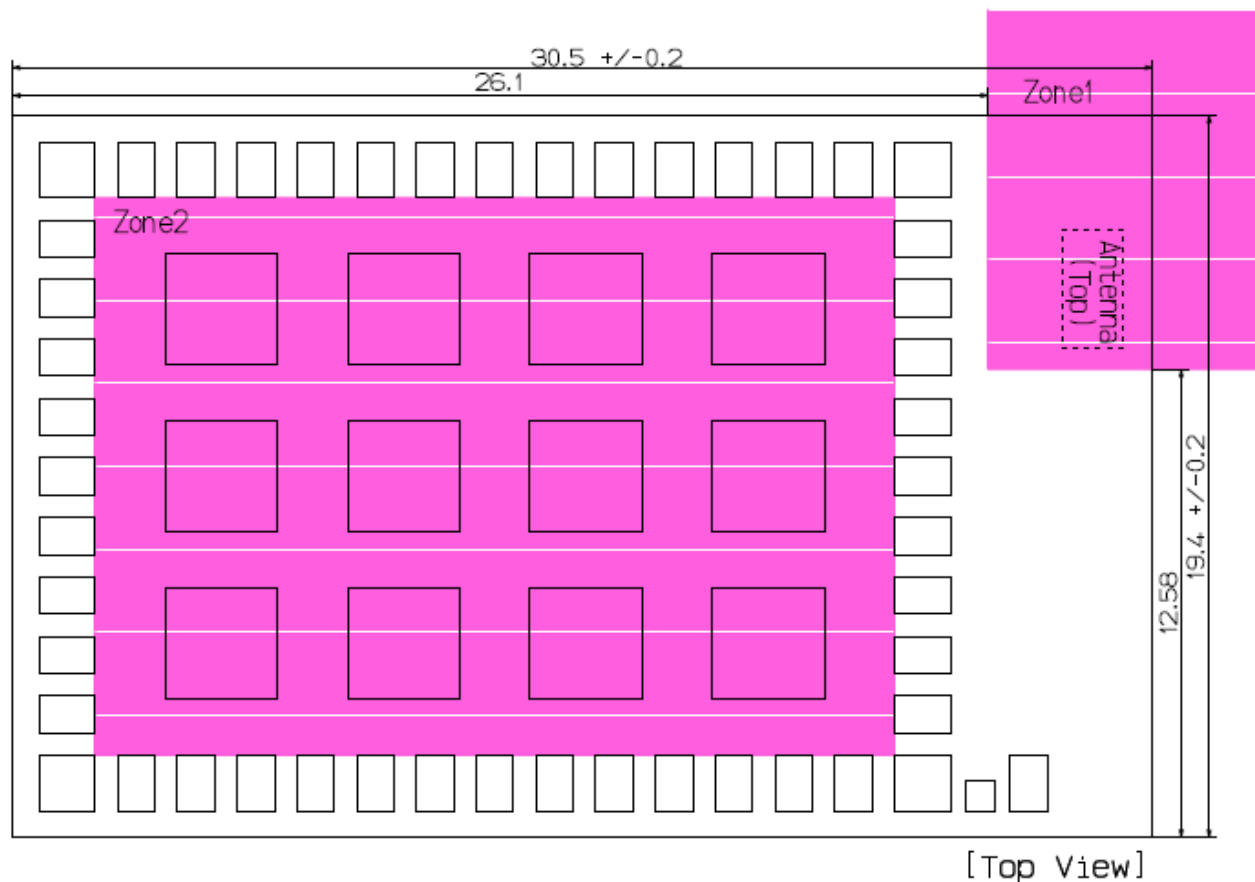

Figure 7 Recommended Host Circuit Board Design underneath the Module

Notes:

1. Due to the surface mount antenna on the module, the area in 'Zone1' on all layers of the customer circuit board should be free of any metal objects. Specifically, there should be no ground plane, traces or metal shield case.
2. The area in 'Zone2' on the top layer of the customer circuit board should have ground only with no signal traces.

6.4 Module Location

For optimum EIRP, customer is advised to use the recommended module location on their host circuit board.

6.4.1 Location in x-y plane

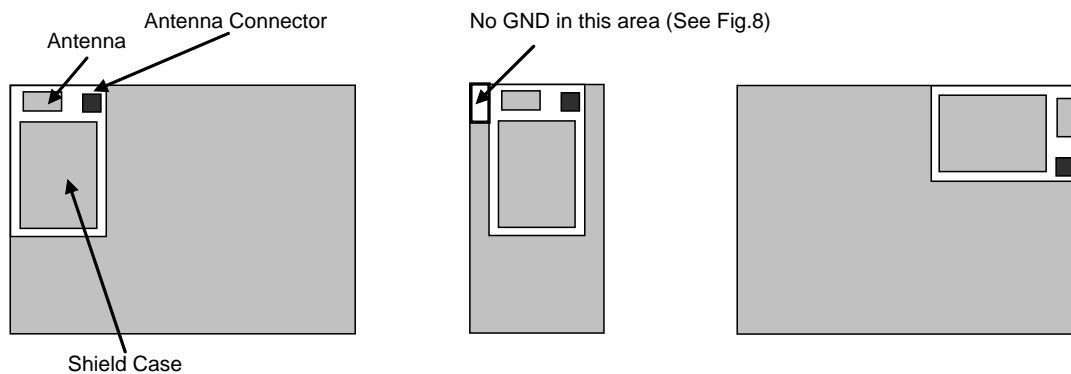

Figure 8 Recommended Locations in xy-plane

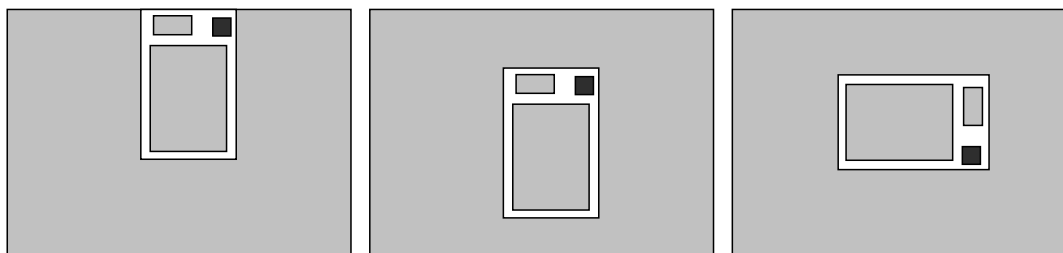

Figure 9 Locations Not Recommended in xy-plane

6.4.2 Location in z-plane

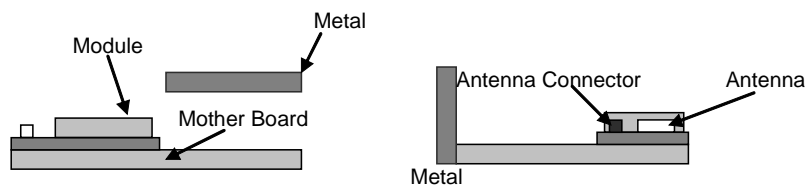

Figure 10 Recommended Locations in z-plane

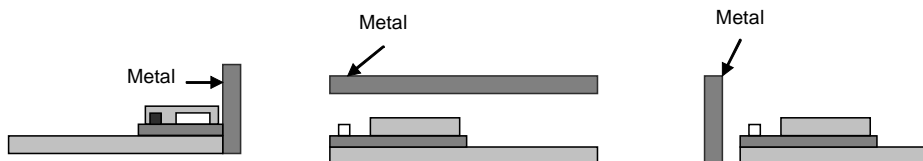

Figure 11 Locations Not Recommended in xy-plane

7 Assembly Information

7.1 Lead-free soldering reflow profile

The lead-free solder reflow profile is recommended in the table & graph below. The profile is used to attach the module to its host PCB.

The module is designed to withstand 2 reflows. Opposite side reflow is prohibited due to the module weight.

Table 8 Reflow Profile Recommendation

Ramp up rate	3°C/second max
Maximum time maintained above 217°C	120 seconds
Peak temperature	250°C
Maximum time within 5°C of peak temperature	20 seconds
Ramp down rate	6°C/second max

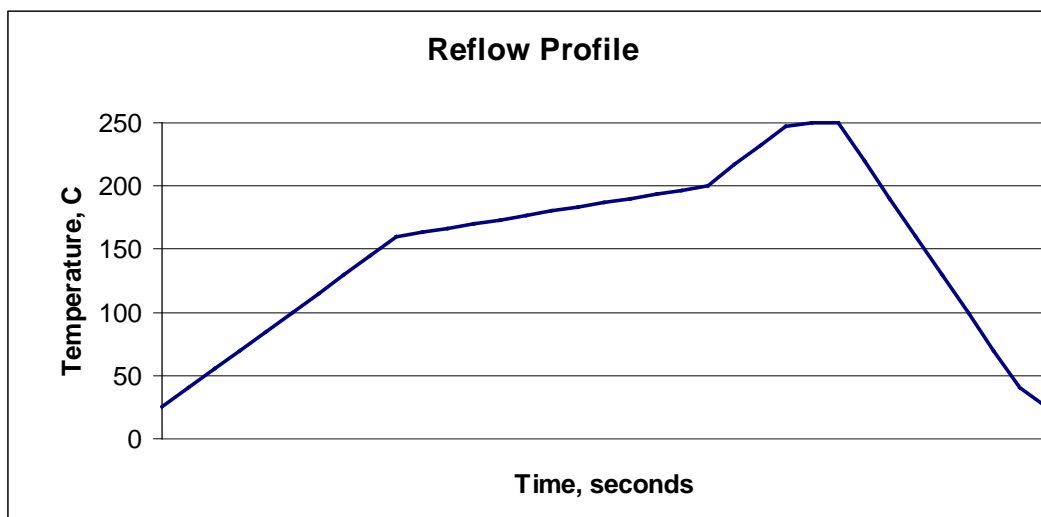

Figure 12 Reflow Profile Pattern

8 Packaging and Marking Information

8.1 Carrier Tape Dimensions

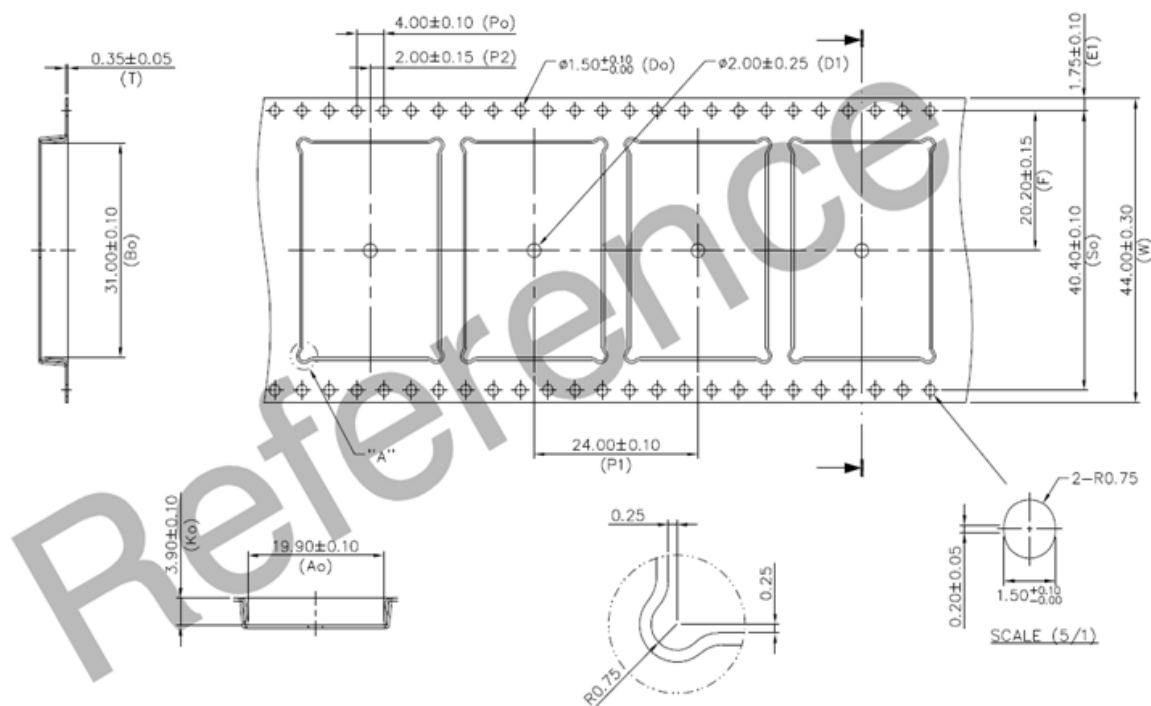

Figure 13 Carrier Tape Dimensions

8.2 Module Marking Information

The following marking information may be printed on a permanent label affixed to the module shield or permanently laser written into the module shield itself. The 2D barcode is used for internal purposes. A pin 1 ID is stamped into the shield.



Figure 14 Module Marking Detail

9 Ordering Information

Table 9 Ordering Information

Product	SyChip Model Number	SyChip Part Number	Standard Order Increment
*Evaluation Development Kit	SN8200EVK	88-00151-85	1 pc
Evaluation Development Kit+	SN8200EVK+	88-00151-95	1 pc
Module in Tape & Reel	SN8200	88-00151-00	400 pcs

10 RoHS Declaration

To the best of our present knowledge, given our supplier declarations, this product does not contain substances that are banned by Directive 2002/95/EC or contain a maximum concentration of 0.1% by weight in homogeneous materials for

- Lead and lead compounds
- Mercury and mercury compounds
- Chromium (VI)
- PBB (polybrominated biphenyl)
- PBDE (polybrominated biphenyl ether)

And a maximum concentration of 0.01% by weight in homogeneous materials for

- Cadmium and cadmium compounds

11 Regulatory Information

SN8200 has obtained the certifications described below.

11.1 FCC Notice (USA)

This device complies with Part 15 of the FCC rules. Operation is subject to the following two conditions: (1) this device may not cause harmful interference, and (2) this device must accept any interference received, including interference that may cause undesired operation.

The FCC requires the OEM to be notified that any changes or modifications not expressly approved by SyChip, LLC may void the user's authority to operate the equipment. While an application of the SN8200 module in a product is not required to obtain a new FCC authorization for the module, this does not preclude the possibility that some other form of authorization or testing may be required for that end product.

This device using the integrated antenna has been tested to comply with FCC CFR Part 15. The device meets the requirements for modular transmitter approval as detailed in the FCC public notice DA00.1407.

This equipment has been tested and found to comply with the limits for a Class B digital device, pursuant to Part 15 of the FCC Rules. These limits are designed to provide reasonable protection against harmful interference in a residential installation. This equipment generates uses and can radiate radio frequency energy and, if not installed and used in accordance with the instructions, may cause harmful interference to radio communications. However, there is no guarantee that interference will not occur in a particular installation. If this equipment does cause harmful interference to radio or television reception, which can be determined by turning the equipment off and on, the user is encouraged to try to correct the interference by one or more of the following measures: reorient or relocate the receiving antenna, increase the separation between the equipment and receiver, connect the equipment into an outlet on a circuit different from that to which the receiver is connected, or consult the dealer or an experienced radio/TV technician for help.

11.2 FCC Labeling Requirements

When integrating the SN8200 into a product the FCC labeling requirements must be met. This includes a clearly visible label on the outside of the finished product specifying the SN8200 FCC identifier (FCC ID:QPU8200) as well as the notice above. The exterior label can use wording such as “Contains Transmitter Module FCC ID:QPU8200” or “Contains FCC ID:QPU8200” although any similar wording that expresses the same meaning may be used.

11.3 RF Exposure

This module has been certified for remote and base radio applications and is not intended to be operated within 20cm of the body. If the module will be used for portable applications, the device must undergo SAR testing.

The following statement must be included as a CAUTION statement in manuals for the products to alert users on FCC RF exposure compliance:

“WARNING: To satisfy FCC RF exposure requirements for mobile transmitting devices, a separation distance of 20cm or more should be maintained between the antenna of this device and persons during operation. To ensure compliance, operations at closer distances than this are not recommended.”

11.4 IC Notice (Canada)

The term “IC” before the certification/registration number only signifies that the Industry Canada technical specifications were met.

Le terme “IC” devant le numéro de certification /d’enregistrement signifie seulement que les spécifications techniques Industrie Canada ont été respectées.

This device complies with Industry Canada license-exempt RSS standard(s). Operation is subject to The following two conditions: (1) this device may not cause interference, and (2) this device must accept any interference, including interference that may cause undesired operation of the device.

Cet appareil est conforme avec Industrie Canada RSS standard exempts de licence (s). Son utilisation est soumise à Les deux conditions suivantes: (1) cet appareil ne peut pas provoquer d'interférences et (2) cet appareil doit accepter Toute interférence, y compris les interférences qui peuvent causer un mauvais fonctionnement du dispositif.

This device complies with Health Canada's Safety Code 6 / IC RSS-210. The installer of this device should ensure that RF radiation is not emitted in excess of the Health Canada's requirement. Information can be obtained at: http://www.hc-sc.gc.ca/ewh-semt/pubs/radiation/radio_guide-lignes_direct-eng.php

Cet appareil est conforme avec Santé Canada Code de sécurité 6 / IC RSS-210. Le programme d'installation de cet appareil doit s'assurer que les rayonnements RF n'est pas émis au-delà de l'exigence de Santé Canada. Les informations peuvent être obtenues: http://www.hc-sc.gc.ca/ewh-semt/pubs/radiation/radio_guide-lignes_direct-eng.php

11.5 IC Labeling Requirements

The host device should be properly labeled to identify the module within the host device. The Industry Canada certification label of a module shall be clearly visible at all times when installed in the host device, otherwise the host device must be labeled to display the Industry Canada certification number of the module, preceded by the words "Contains transmitter module", or the word "Contains", or similar wording expressing the same meaning, as follows:

Contains transmitter module IC:4523A-SN8200,
where 4523A-SN8200 is the module's certification number.

11.6 CE Notice (Europe)

This device has been tested and certified for use in the European Union.

If this device is used in a product, the OEM has responsibility to verify compliance of the final product to the EU standards. A Declaration of Conformity must be issued and kept on file as described in Annex II of the Radio and Telecommunications Terminal Equipment Directive.

11.7 CE Labeling Requirements

The 'CE' mark must be placed on the OEM product per the labeling requirements of the Directive. Given that the operating frequency band is not harmonized by a few European countries, the restriction or alert sign must be placed alongside the 'CE' mark as shown below. As of the date of this document, only France has a restriction. The restriction is that, if the radio is operated outdoors in the 2450-2483.5 MHz band, the power must be limited to 10 mW instead of 100 mW. The OEM must account for this and the product must have the alert mark. It does not require country notifications, however.



12 Technical Support Contact

SyChip LLC
2805 Dallas Parkway, Suite 400
Plano, TX 75093
USA
Tel: (972) 202-8900
Fax: (972) 633-0327

Note: SyChip LLC is an operating unit within Murata Wireless Solutions

13 Disclaimer

Please read this notice before using the SN8200 product.

1. Please note that the only warranty that SyChip LLC (“SyChip”) provides regarding the products is its conformance to the specifications provided herein. Accordingly, SyChip shall not be responsible for any defects in products or equipment incorporating such products, which are caused under the conditions other than those specified in this specification.

SYCHIP HEREBY DISCLAIMS ALL OTHER WARRANTIES REGARDING THE PRODUCTS, EXPRESS OR IMPLIED, INCLUDING WITHOUT LIMITATION ANY WARRANTY OF FITNESS FOR A PARTICULAR PURPOSE, THAT THEY ARE DEFECT-FREE, OR AGAINST INFRINGEMENT OF INTELLECTUAL PROPERTY RIGHTS. YOU AGREE TO INDEMNIFY AND DEFEND SYCHIP AND ITS AFFILIATES AGAINST ALL CLAIMS, DAMAGES, COSTS AND EXPENSES THAT MAY BE INCURRED, INCLUDING WITHOUT LIMITATION, ATTORNEY FEES AND COSTS, DUE TO THE USE OF PRODUCTS.

2. The product is designed and manufactured for general applications, and not for any particular application, so testing and use of the product shall be conducted at your own risk and responsibility. Specifically, please observe the following:

- i) Please conduct validation and verification of the products in actual condition of mounting and operating environment before commercial shipment of the equipment.
- ii) Please pay attention to minimize any mechanical vibration or shock, not to drop the product or a substrate that contains the product during transportation.
- iii) Since the application of static electricity or overvoltage may cause a defect in the product or deterioration of its reliability, caution must be taken against exposure to any static electricity generated by electrified items such as work benches, soldering irons, tools, carrying containers, etc.
- iv) Caution shall be taken to avoid overstress to the product during and after the soldering process.

- v) Since the applied soldering method may deteriorate the reliability, thorough evaluation is recommended.
- vi) In case the product is to be used in equipment or electric circuit that requires high safety or reliability function or performance, sufficient reliability evaluation checks for safety shall be performed before commercial shipment and moreover, due consideration to install a protective circuit is strongly recommended at customer's design stage. Please provide an appropriate fail-safe function on your product to prevent any damages that may be caused by the abnormal function or the failure of our product.

Notwithstanding the foregoing, the product shall not be used in any application listed below which requires especially high reliability for the prevention of such defect as may directly cause damage to the third party's life, body or property.

- Aircraft equipment
- Aerospace equipment
- Undersea equipment
- Power plant control equipment
- Medical equipment
- Transportation equipment (vehicles, trains, ships, etc.)
- Traffic signal equipment
- Disaster prevention / crime prevention equipment
- Application of similar complexity and/or reliability requirements to the applications listed in the above.

3. SyChip's warranty as provided in Clause 1 above that the products comply with descriptions expressly specified in the specifications shall be effective for a period of six (6) months from the date of delivery. SyChip shall not be liable for any defects that occur in dry packed products that are installed more than six (6) months after shipment.

SyChip's liability under this warranty shall be limited to products that are returned during the warranty period to the address designated by SyChip and that are determined by SyChip not to conform to such warranty. If SyChip elects to repair or replace such products, SyChip shall have reasonable time to repair such products or provide replacements. Repaired products shall be warranted for the remainder of the original warranty period. Replaced products shall be warranted for a new full warranty period.

For avoidance of doubt, SyChip shall not be liable for any defects that are caused by neglect, misuse or mistreatment by an entity other than SyChip including improper installation or testing, or for any products that have been altered or modified in any way by an entity other than SyChip. Moreover, SyChip shall not be liable for any defects that result from your or third party's design, specifications or instructions for such products.

4. Testing and other quality control techniques are used to the extent SyChip deems necessary. Unless mandated by government requirements, SyChip does not necessarily test all parameters of each product.

5. End of Life - Please note that we may discontinue the manufacture of products, due to reasons such as, but not limited to, end of supply of materials and/or components from our suppliers.