

Type UW – Wi-Fi / BT Module

Module Part Number: LBEH5Z9UWC

PRODUCT BRIEF

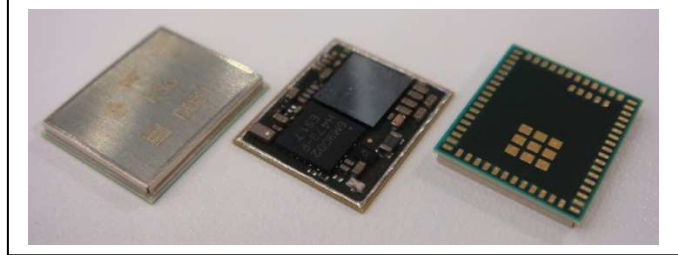

Description

The **Type UW** module is an ultra small wireless solution providing IEEE802.11 a/b/g/n + BT v4 (BLE) connectivity. The module integrates the Texas Instrument’s WL1273L SoC, RFFE, and DC-DC converter. The module is designed to fit into a small space area with minimal circuitry to complete a radio design. The customer simply provides standard circuit board design practices and enable antenna through 50 Ohm trace to module pin. The module includes an RF pad interface to launch directly on the customer board.

The module is intended for use on select Texas Instruments microprocessor platforms including OMAP3x, and OMAP4x series, platform where WLAN and BT board support software packages are readily available enabling rapid product design cycles. For further details on recommended platforms, please contact Murata Wireless Solution at www.murata-ws.com.

The Type UW wireless module will be offered on a evaluation board for RF testing on module to begin evaluation efforts prior to the schematic and layout cycle. The evaluation board and samples can be ordered with part number;

Evaluation kit: LBEH5Z9UWC-TEMP-D

Samples: LBEH5Z9UWC-TEMP

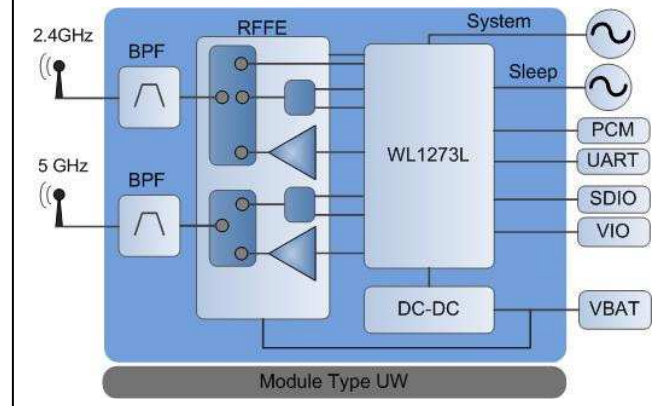

Characteristics

Chipset	WL1273L
Supply voltage	3.0 to 4.2 Vdc for VBAT
Interface voltage	1.8 Vdc for VIO
Operating Temperature	-20 to +70 deg C
Dimensions	11.4 x 9.4 x 1.4mm max
Package	74-pin LGA
WLAN RF Power	+12dBm typ. 65Mbps 2.4GHz +12dBm typ. 65Mbps 5GHz +18dBm typ. 11Mbps
WLAN Sensitivity	-70dBm typ. 65Mbps 2.4GHz -67dBm typ. 65Mbps 5GHz -87dBm typ. 11Mbps
Bluetooth	Power class 1.5

Note: Murata Inc. reserves the right to make changes in specifications at anytime and without notice. The information furnished in this product brief is believed to be accurate and reliable. However, no responsibility is assumed by Murata for its use, nor any infringements of patents or other rights of third parties resulting from its use. No license is generated under any rights of Murata or its supporters unless specifically agreed.