

TECRL Series

Thermoelectrically Cooled RED Laser System

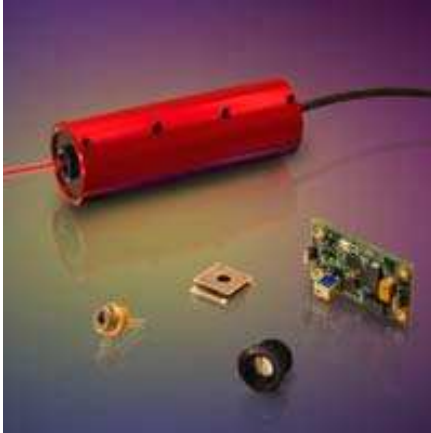

WSTech's **TECRL Series Thermoelectrically Cooled Red Laser Module** features red lasers from 635nm to 690 nm with an integrated TEC and driver circuit in a compact self-contained rugged package. The built-in temperature controller maintains the laser diode temperature within $\pm 0.01^{\circ}\text{C}$ resulting in excellent power stability that varies less than 1% over long term. Additional benefits are low noise, very narrow bandwidth and excellent beam pointing stability. These characteristics make the TECRL series lasers ideal for bioanalytical, measurement and imaging applications.

TECRL series lasers are available in output power ranges of 1 to 50 mW. The standard version is CW with elliptical beam, and comes with a power supply for plug and play operation. Modulated options (TTL) with 0 to 155MHz, power variable options (PV) and circularized beam options are also available.

Product Features

- ***Integrated TEC & Laser Controller***
- ***Low RMS Noise***
- ***Excellent Power and Wavelength Stability***
- ***Excellent Beam Quality***
- ***Compact Size, 1 x 3 inch***
- ***ESD and Over-Temperature Protection***
- ***Long Life Time***
- ***Low Power Consumption, < 2W***

Applications

- ***Bioanalytical***
- ***DNA Sequencing***
- ***Flow Cytometry***
- ***Medical Imaging***
- ***Capillary Electrophoresis***
- ***Confocal Microscopy***
- ***Particle Counting***
- ***Interferometer***
- ***Printing (Reprographics)***

TECRL Series

Thermoelectrically Cooled Red Laser System

Specification

Optical	Wavelength	635 to 690 nm
	Power Stability	<0.5%
	RMS Noise(0~20MHz)	<0.5%
	P-P Noise	<5% over 8hrs
	Spatial Mode	Single Mode Laser
	Spot Size	Adjustable or Collimated (5mm)
	Divergence at the collimation	< 1 mrad
	Beam shape	Elliptical (Circular option available)
	Pointing Stability	< ±25 μrad
	Polarization	Linear, 100:1
	Electrical	Laser Drive
Laser Operating Voltage		3.3V DC
Operating Current		<0.5A
Driving Circuit		Constant current control
Electrical Connections		2.1mm power jack
Mechanical	Power Supply	100 – 240VAC, 50 – 60 Hz
	Dimension (Dia x L)	25.4 x 76.2 mm (1" x 3")
	Operating Temperature	10°C to +40°C(With adequate heat sink)
	Storage Temperature	-10°C to +50°C
	Heat Sink Requirements	Recommended for extended use

Thermal Management: The TECRL Series Laser System is designed to dissipate heat through its body. Please ensure that the mounting brackets are not made of insulating material. For proper heat dissipation and cooling, do not restrict air circulation around the device. An additional heat sink with integrated fan can be used to maximize the performance and extend the life of the laser system.

Mechanical Drawing

Laser

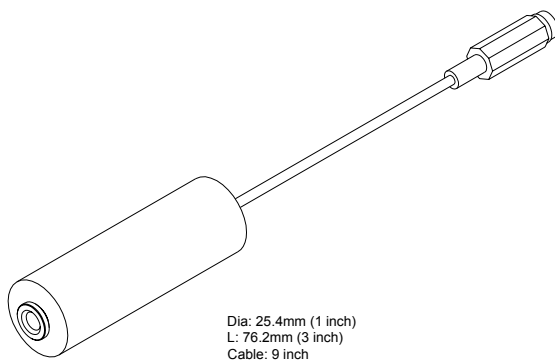

Power Supply

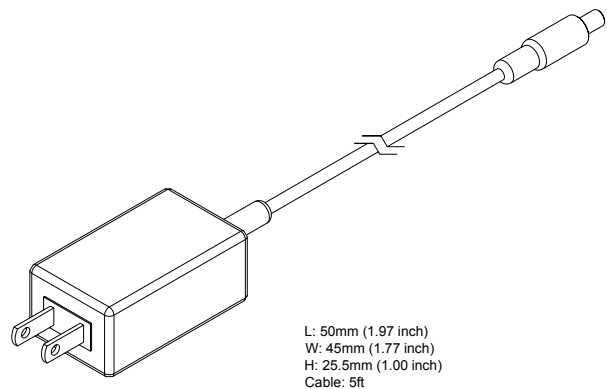

TECRL Series

Thermoelectrically Cooled Red Laser System

Typical Characteristics

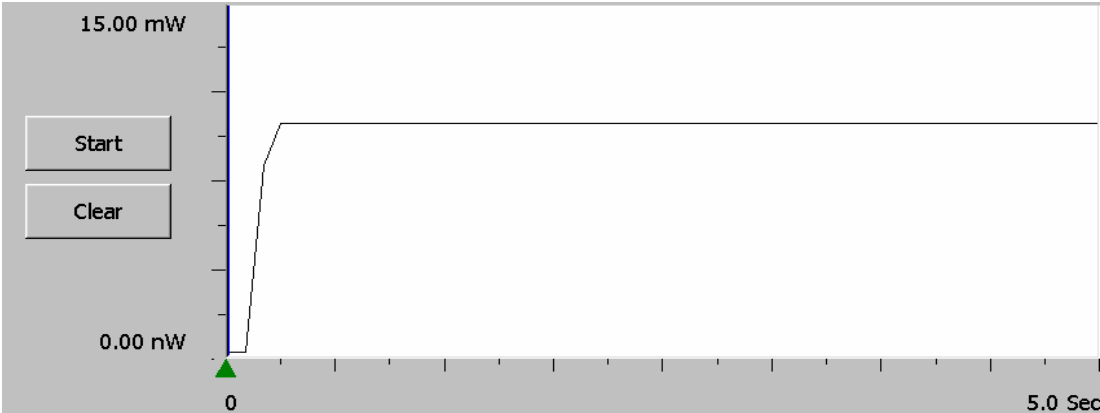

Warm up time

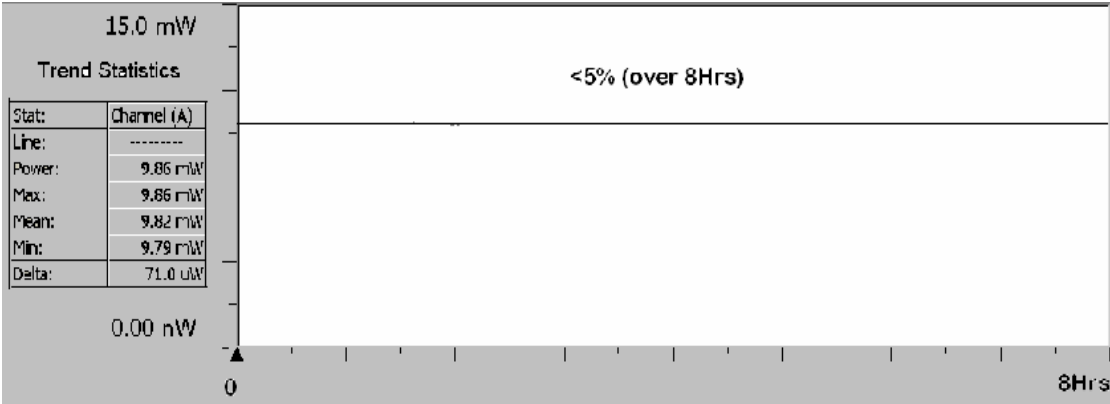

Peak to Peak Noise

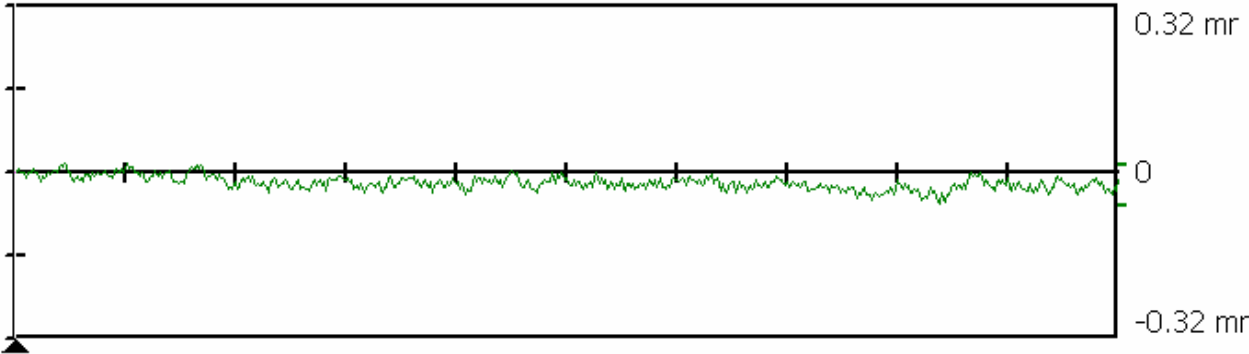

Beam Pointing Stability

TECRL Series



Thermoelectrically Cooled Red Laser System

Order Information

Power	Wavelength				Classification
	635nm	650nm	670nm	690nm	
1 mW	TECRL- 1G-635	TECRL- 1G-650	TECRL- 1G-670		Class II*
3.5 mW	TECRL-3.5G-635	TECRL-3.5G-650	TECRL-3.5G-670		Class IIIa*
7 mW	TECRL- 7G-635	TECRL- 7G-650	TECRL- 7G-670		Class IIIb**
10 mW	TECRL-10G-635				
15 mW	TECRL-15G-635				
20 mW	TECRL-20G-635	TECRL-20G-650		TECRL-20G-690	
25 mW	TECRL-25G-635	TECRL-25G-650			
30 mW		TECRL-30G-650			
50 mW		TECRL-50G-650			

TTL option is available upon request, it can operate from CW up to 155MHz, and the part No. will add -TTL, e.g. TECRL-7G-635-TTL.
 PV option is available upon request and the part No. will add -PV, e.g. TECRL-7G-635-PV.

*Complies with CDRH 21CFRH 1040.10

** Module components sold solely for use in OEM equipment, OEM is responsible for compliance with all applicable safety regulations.



Operational Hazard-Semiconductor Laser Diode Module: This laser module emits radiation that is visible and harmful to human eye. When in use, do not look directly into the laser emitting aperture. Direct viewing of laser diode emission at close range may cause eye damage.

Limited Warranty: One year. No warranty coverage for disassembly, modifications or damage due to abuse or misapplication.

World Star Tech.

321 Lesmill Rd. Toronto, Ont. M3B 2V1 Canada
 Tel: (416) 363-3332 Fax: (416) 363-3112 www.worldstartech.com

Rev.C Jan. 2006