

---

# HL6322G

AlGaInP Laser Diode

# HITACHI

ADE-208-599B (Z)  
3rd Edition  
Aug. 1998

---

## Description

The HL6322G are 0.63  $\mu\text{m}$  band AlGaInP laser diodes with a multi-quantum well (MQW) structure.

It is suitable as light sources for laser leveler and optical equipment for measurement.

## Application

- Laser leveler
- Measurement

## Features

- Visible light output : 635 nm Typ (nearly equal to He-Ne gas laser)
- Optical output power : 15 mW CW
- Low operating current : 100 mA Max
- Low operating voltage : 2.7 V Max

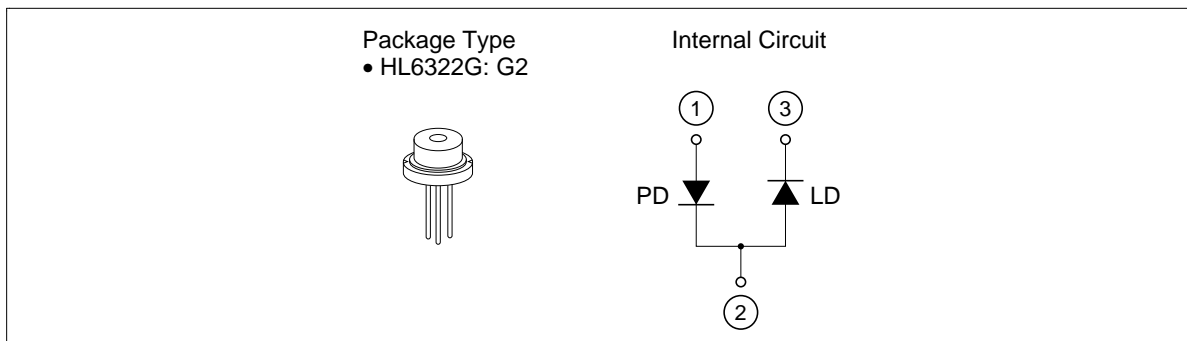

---

## HL6322G

---

### Absolute Maximum Ratings ( $T_C = 25^\circ\text{C}$ )

Item	Symbol	Value	Unit
Optical output power	$P_O$	15	mW
LD reverse voltage	$V_{R(LD)}$	2	V
PD reverse voltage	$V_{R(PD)}$	30	V
Operating temperature	$T_{opr}$	-10 to +50	$^\circ\text{C}$
Storage temperature	$T_{stg}$	-40 to +85	$^\circ\text{C}$

### Optical and Electrical Characteristics ( $T_C = 25^\circ\text{C}$ )

Item	Symbol	Min	Typ	Max	Unit	Test Condition
Optical output power	$P_O$	15	—	—	mW	Kink free*
Threshold current	$I_{th}$	20	55	70	mA	
Operating current	$I_{op}$	—	85	100	mA	$P_O = 15\text{ mW}$
Operating voltage	$V_{OP}$	—	—	2.7	V	$P_O = 15\text{ mW}$
Slope efficiency	$\eta_s$	0.3	0.5	0.7	mW/mA	$9(\text{mW}) / (I_{(12\text{mW})} - I_{(3\text{mW})})$
Lasing wavelength	$\lambda_p$	630	635	640	nm	$P_O = 15\text{ mW}$
Beam divergence parallel to the junction	$\theta_{//}$	6	8	11	deg.	$P_O = 15\text{ mW}$
Beam divergence perpendicular to the junction	$\theta_{\perp}$	25	30	36	deg.	$P_O = 15\text{ mW}$
Monitor current	$I_s$	0.1	0.2	0.4	mA	$P_O = 15\text{ mW}, V_{R(PD)} = 5\text{V}$

Note: Kink free is confirmed at the temperature of  $25^\circ\text{C}$ .

Typical Characteristics Curves

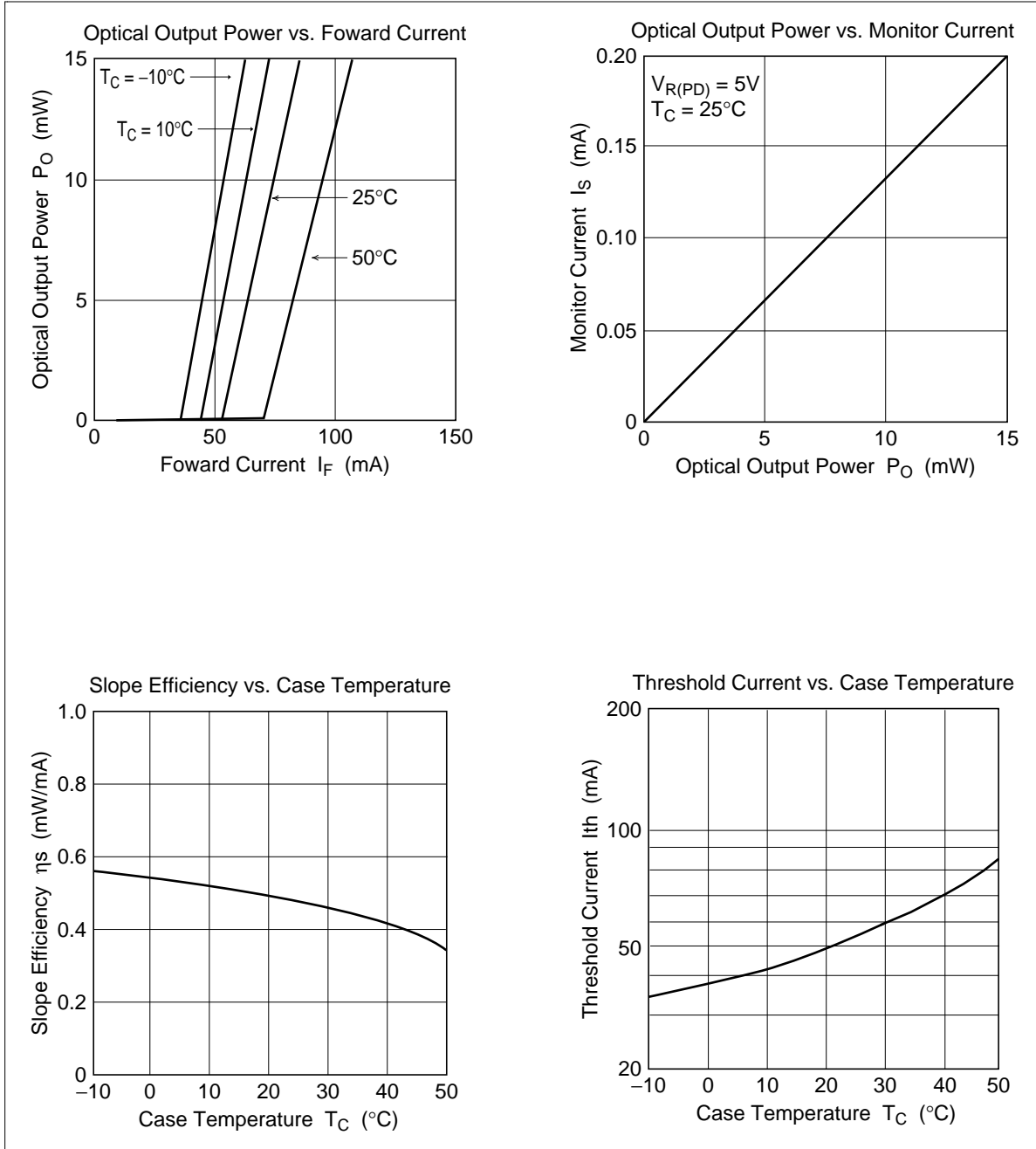

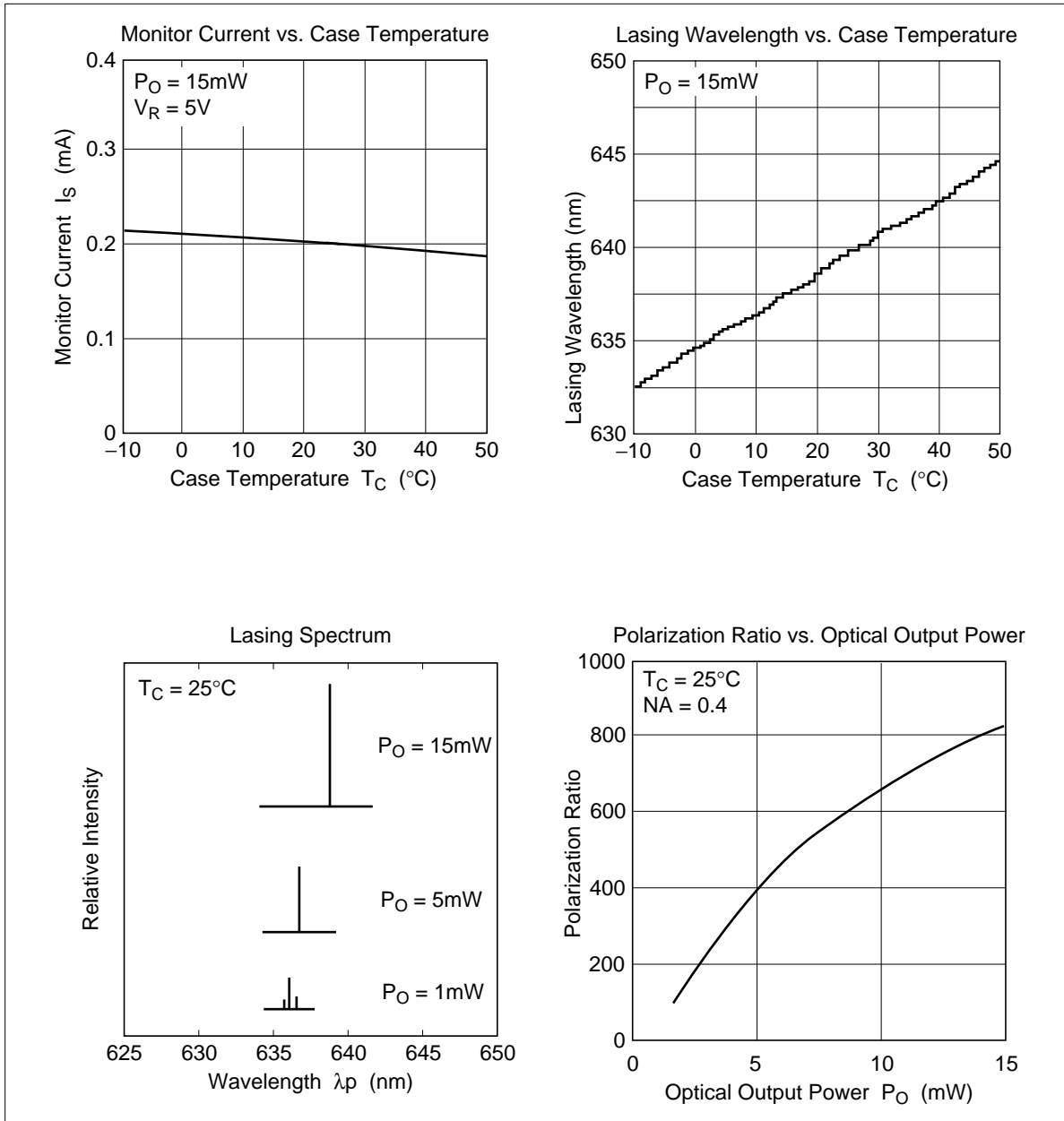

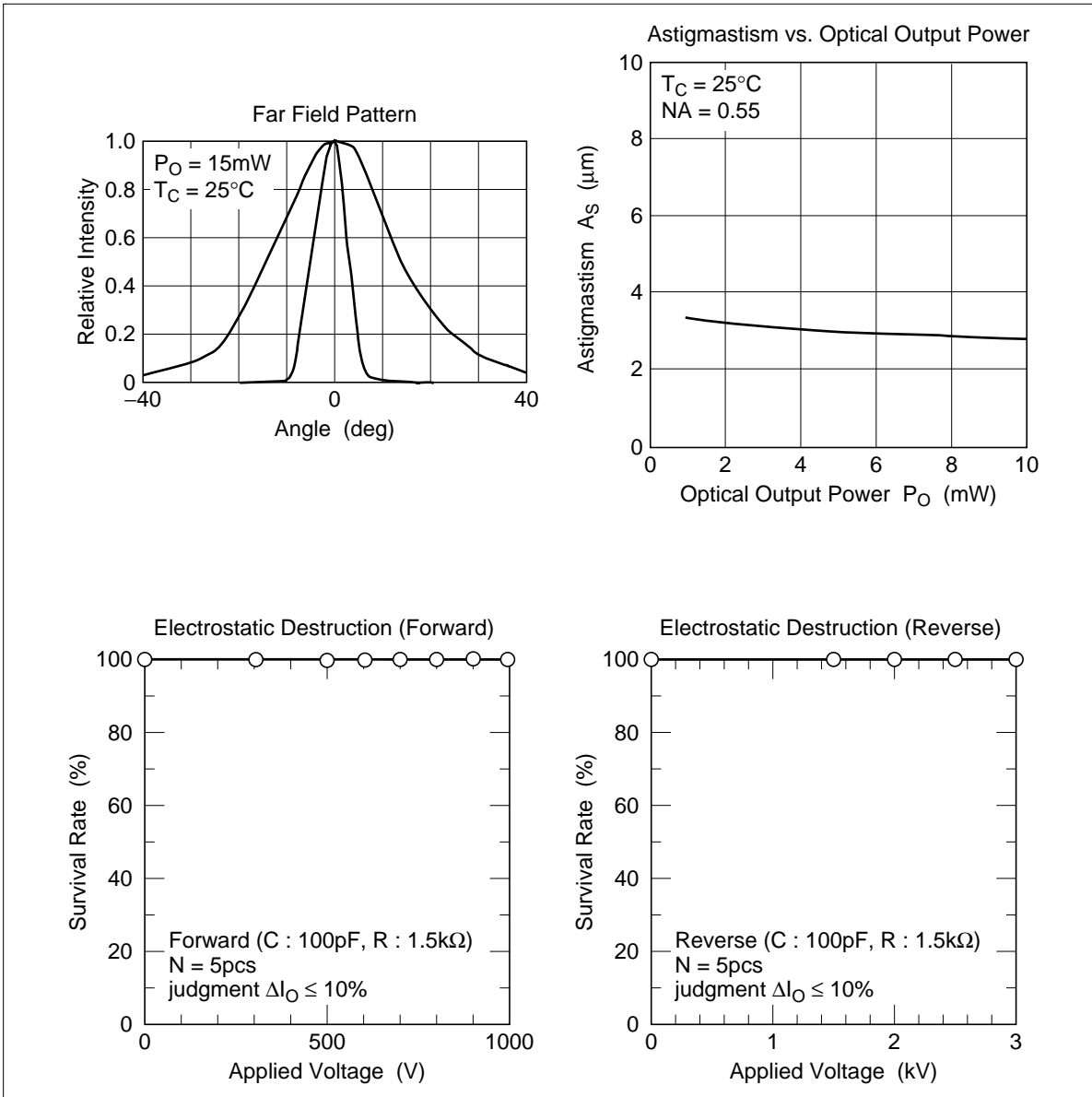

**Polarization direction**

The polarization direction is TM mode.

The polarization direction of 0.63  $\mu\text{m}$  LDs is different from that 0.83/0.78/0.67  $\mu\text{m}$  LDs.

The polarization direction of 0.63  $\mu\text{m}$  LDs is illustrated in the figure below.

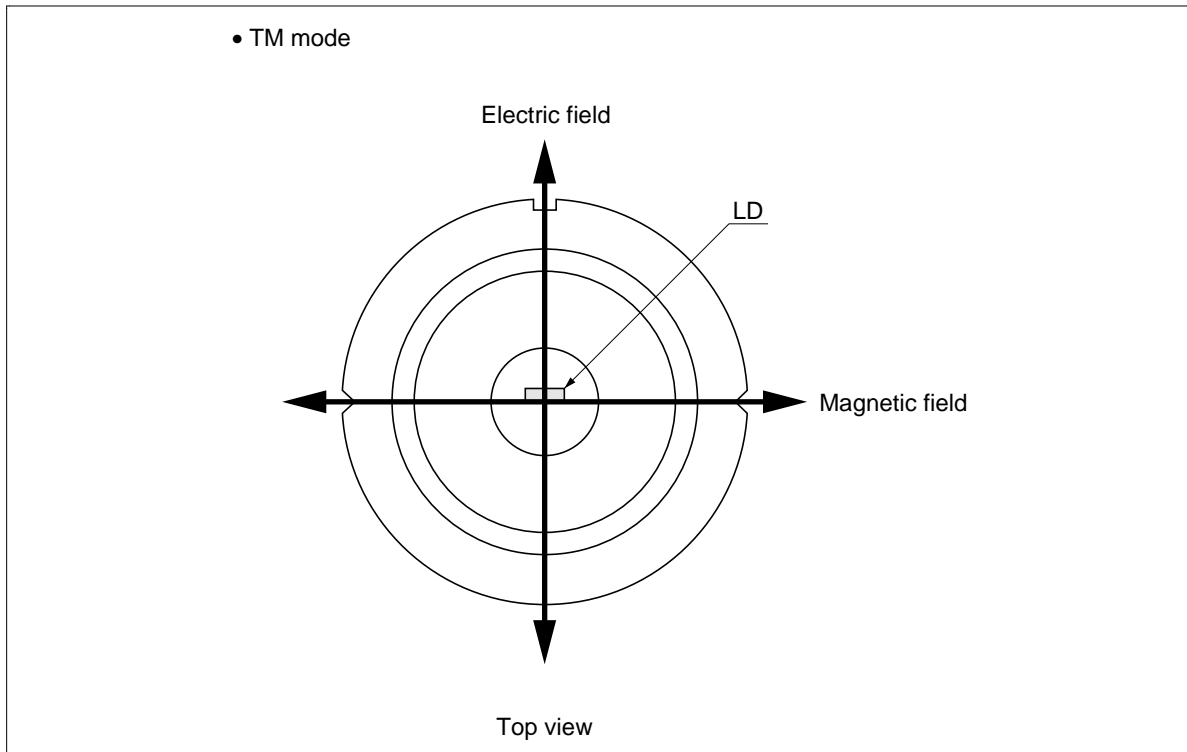

Package Dimensions

Unit: mm

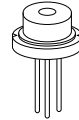
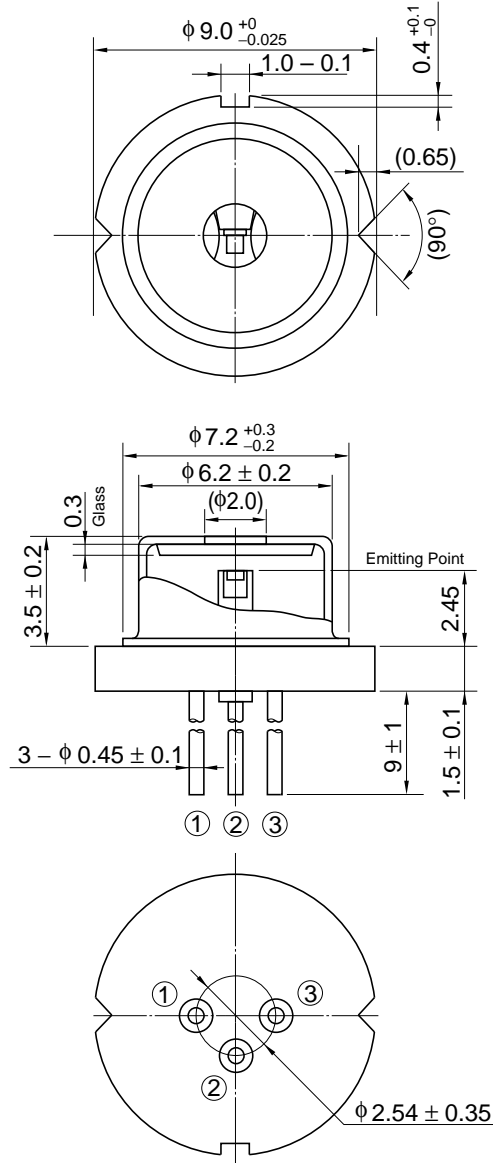

Hitachi Code	LD/G2
JEDEC	—
EIAJ	—
Weight (reference value)	1.1 g

**Cautions**

1. Hitachi neither warrants nor grants licenses of any rights of Hitachi's or any third party's patent, copyright, trademark, or other intellectual property rights for information contained in this document. Hitachi bears no responsibility for problems that may arise with third party's rights, including intellectual property rights, in connection with use of the information contained in this document.
2. Products and product specifications may be subject to change without notice. Confirm that you have received the latest product standards or specifications before final design, purchase or use.
3. Hitachi makes every attempt to ensure that its products are of high quality and reliability. However, contact Hitachi's sales office before using the product in an application that demands especially high quality and reliability or where its failure or malfunction may directly threaten human life or cause risk of bodily injury, such as aerospace, aeronautics, nuclear power, combustion control, transportation, traffic, safety equipment or medical equipment for life support.
4. Design your application so that the product is used within the ranges guaranteed by Hitachi particularly for maximum rating, operating supply voltage range, heat radiation characteristics, installation conditions and other characteristics. Hitachi bears no responsibility for failure or damage when used beyond the guaranteed ranges. Even within the guaranteed ranges, consider normally foreseeable failure rates or failure modes in semiconductor devices and employ systemic measures such as fail-safes, so that the equipment incorporating Hitachi product does not cause bodily injury, fire or other consequential damage due to operation of the Hitachi product.
5. This product is not designed to be radiation resistant.
6. No one is permitted to reproduce or duplicate, in any form, the whole or part of this document without written approval from Hitachi.
7. Contact Hitachi's sales office for any questions regarding this document or Hitachi semiconductor products.

1. The laser light is harmful to human body especially the eye no matter how directly or indirectly. The laser beam shall be observed or adjusted through infrared camera or equivalent.

---

---

# HITACHI

**Hitachi, Ltd.**

Semiconductor & IC Div.  
Nippon Bldg., 2-6-2, Ohte-machi, Chiyoda-ku, Tokyo 100-0004, Japan  
Tel: Tokyo (03) 3270-2111 Fax: (03) 3270-5109

URL   NorthAmerica   : <http://semiconductor.hitachi.com/>  
      Europe           : <http://www.hitachi-eu.com/hel/ecg>  
      Asia (Singapore) : <http://www.has.hitachi.com.sg/grp3/sicd/index.htm>  
      Asia (Taiwan)    : [http://www.hitachi.com.tw/E/Product/SICD\\_Frame.htm](http://www.hitachi.com.tw/E/Product/SICD_Frame.htm)  
      Asia (HongKong) : <http://www.hitachi.com.hk/eng/bo/grp3/index.htm>  
      Japan            : <http://www.hitachi.co.jp/Sicd/indx.htm>

**For further information write to:**

Hitachi Semiconductor  
(America) Inc.  
2000 Sierra Point Parkway  
Brisbane, CA 94005-1897  
Tel: <1> (800) 285-1601  
Fax: <1> (303) 297-0447

Hitachi Europe GmbH  
Electronic components Group  
Domacher Straße 3  
D-85622 Feldkirchen, Munich  
Germany  
Tel: <49> (89) 9 9180-0  
Fax: <49> (89) 9 29 30 00

Hitachi Europe Ltd.  
Electronic Components Group.  
Whitebrook Park  
Lower Cookham Road  
Maidenhead  
Berkshire SL6 8YA, United Kingdom  
Tel: <44> (1628) 585000  
Fax: <44> (1628) 778322

Hitachi Asia Pte. Ltd.  
16 Collyer Quay #20-00  
Hitachi Tower  
Singapore 049318  
Tel: 535-2100  
Fax: 535-1533

Hitachi Asia Ltd.  
Taipei Branch Office  
3F, Hung Kuo Building, No.167,  
Tun-Hwa North Road, Taipei (105)  
Tel: <886> (2) 2718-3666  
Fax: <886> (2) 2718-8180

Hitachi Asia (Hong Kong) Ltd.  
Group III (Electronic Components)  
7/F., North Tower, World Finance Centre,  
Harbour City, Canton Road, Tsim Sha Tsui,  
Kowloon, Hong Kong  
Tel: <852> (2) 735 9218  
Fax: <852> (2) 730 0281  
Telex: 40815 HITEC HX

Copyright © Hitachi, Ltd., 1998. All rights reserved. Printed in Japan.