

Powerex, Inc., 200 Hillis Street, Youngwood, Pennsylvania 15697-1800 (724)925-7272

**Phase Control Thyristor**  
1660 Amperes/Up to 1800 Volts

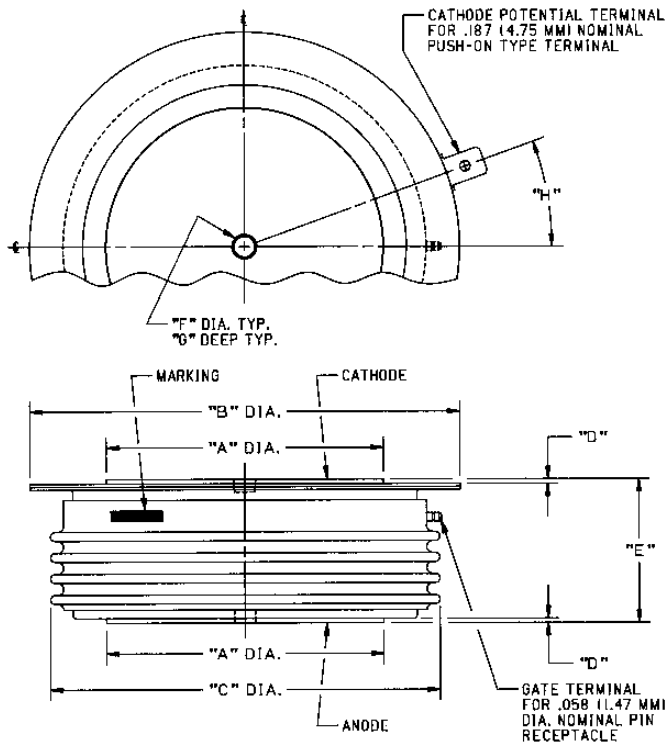

CASE NUMBER T9G STRIKE DISTANCE = .67 (17.0 MM) MIN.  
NOMINAL DIMENSIONS CREEPAGE DISTANCE = 1.04 (26.4 MM) MIN.)

SYM.	A	B	C	D	E	F	G	H
INCHES	1.85	2.87	2.60	.030	1.040/1.080	.140	.085	20°
[MM]	47.0	72.9	66.0	0.76	26.42/27.43	3.56	2.16	20°

**Description:**

The T9G0 is a medium voltage, high current disc pack SCR employing a center fired, amplifying gate structure suitable for operation to 400 Hz. The amplifying gate allows this SCR to be reliably operated at high di/dt and high dv/dt conditions in phase control applications.



**Features:**

- Low On-State Voltage
- High di/dt Capability
- High dv/dt Capability
- Hermetic Packaging
- Excellent Surge and I<sup>2</sup>t Ratings
- Replaces PRX C450 Thyristor

**Applications:**

- DC Power Supplies
- Motor Controls
- AC Switches

**Ordering Information**

Select the complete 10 digit device part number from the table below, ie. T9G0161603 is a 1600V 1660A Phase Control SCR.

	Voltage V <sub>DRM</sub> V <sub>RRM</sub>	Voltage Code	Current I <sub>T(avg)</sub>	Current Code	T <sub>q</sub>	I <sub>GT</sub>
<b>T9G0</b>	1200V	<b>12</b>	1660A	<b>16</b>	<b>0</b>	<b>3</b>
	1400V	<b>14</b>				
	1600V	<b>16</b>				
	1800V	<b>18</b>				

**Absolute Maximum Ratings**

Characteristics	Symbol		Units
Repetitive Peak Reverse Voltage	$V_{RRM}$	1200 1400 1600 1800	V
Repetitive Peak Forward Voltage	$V_{DRM}$	1200 1400 1600 1800	V
RMS On-State Current, $T_C=70^\circ\text{C}$	$I_{T(RMS)}$	2600	A
Average Current 180° Sine Wave, $T_C=70^\circ\text{C}$	$I_{T(AV)}$	1660	A
RMS On-State Current, $T_C=55^\circ\text{C}$	$I_{T(RMS)}$	3140	A
Average Current 180° Sine Wave, $T_C=55^\circ\text{C}$	$I_{T(AV)}$	2000	A
Peak One Cycle Surge On-State Current (Non-Repetitive) 60Hz, $V_R = 0V$	$I_{TSM}$	29,000	A
Peak One Cycle Surge On-State Current (Non-Repetitive) 50Hz, $V_R = 0V$	$I_{TSM}$	27,400	A
Critical Rate-of-Rise of On-State Current (Non-Repetitive)*	di/dt	1000	A/ $\mu\text{s}$
Critical Rate-of-Rise of On-State Current (Repetitive)*	di/dt	400	A/ $\mu\text{s}$
$I^2t$ for Fusing for One Cycle, 60 Hz	$I^2t$	$3.54 \times 10^6$	$\text{A}^2\text{s}$
$I^2t$ for Fusing for One Cycle, 50 Hz	$I^2t$	$3.75 \times 10^6$	$\text{A}^2\text{s}$
Peak Gate Power Dissipation	$P_{GM}$	2000	W
Average Gate Power Dissipation	$P_{G(av)}$	5	W
Operating Temperature	$T_J$	-40 to 125°C	°C
Storage Temperature	$T_{STG}$	-40 to 150°C	°C
Approximate Weight		1 0.45	lb. Kg
Mounting Force		5500 – 6000 2450 -- 2670	lb. Kg

\* NON-JEDEC Test Conditions

**Electrical Characteristics,  $T_J=25^\circ\text{C}$  unless otherwise specified**

Characteristics	Symbol	Test Conditions	Min.	Typ.	Max.	Units
Repetitive Peak Reverse Leakage Current	$I_{RRM}$	$T_J=125^\circ\text{C}$ , $V_R=V_{RRM}$			75	mA
Repetitive Peak Forward Leakage Current	$I_{DRM}$	$T_J=125^\circ\text{C}$ , $V_D=V_{DRM}$			75	mA
Peak On-State Voltage	$V_{TM}$	$I_{TM}=1500\text{A}$ Duty Cycle < 0.01%			1.25	V
Threshold Voltage, Low-level Slope Resistance, Low-level	$V_{(TO)1}$ $r_{T1}$	$T_J=125^\circ\text{C}$ , $I = 15\% I_{AV}$ to $\pi I_{AV}$		.834 .164		V m $\Omega$
$V_{TM} = V_{TO} + r_T \times I_{TM}$						
Threshold Voltage, High-level Slope Resistance, High-level	$V_{(TO)2}$ $r_{T2}$	$T_J=125^\circ\text{C}$ , $I = \pi I_{AV}$ to $I_{TSM}$		.993 .126		V m $\Omega$
$V_{TM} = V_{TO} + r_T \times I_{TM}$						
VTM Coefficients		$T_J=125^\circ\text{C}$ , $I = 15\% I_{AV}$ to $I_{TSM}$		A= .109 B= .136 C= 1.35-4 D= -.00457		
$V_{TM} = A + B \times \ln(I_{TM}) + C \times I_{TM} + D \times (I_{TM})^{1/2}$						
Typical Delay Time	$t_d$	$V_D = V_{DRM}$ Gate Drive: 20V - 20 $\Omega$ - 0.1 $\mu\text{s}$		1		$\mu\text{s}$
Typical Turn-Off Time	$t_q$	$T_J=125^\circ\text{C}$ , $I_T=400\text{A}$ , $V_R>50\text{V}$ , reapplied $dv/dt=20\text{V}/\mu\text{s}$ linear to 80% $V_{DRM}$		150		$\mu\text{s}$
Minimum Critical $dv/dt$ - linear to $V_{DRM}$	$dv/dt$	$T_J=125^\circ\text{C}$ , $V_{DRM}=80\%$ rated Gate Open	400			V/ $\mu\text{s}$
Gate Trigger Current	$I_{GT}$	$T_J=25^\circ\text{C}$ , $V_D=12\text{V}$	30	100	200	mA
Gate Trigger Voltage	$V_{GT}$	$T_J=25^\circ\text{C}$ , $V_D=12\text{V}$	0.8	1.5	3.0	V
Peak Reverse Gate Voltage	$V_{GRM}$				5	V

**Thermal Characteristics**

Characteristics	Symbol	Min.	Typ.	Max.	Units
Maximum Thermal Resistance, Double Sided Cooling					
Junction to Case	$R_{\theta JC}$			.023	$^\circ\text{C}/\text{W}$
Case to Sink	$R_{\theta CS}$			.006	$^\circ\text{C}/\text{W}$

**Maximum On-State Forward Voltage Drop**

( $T_j = 125^\circ\text{C}$ )

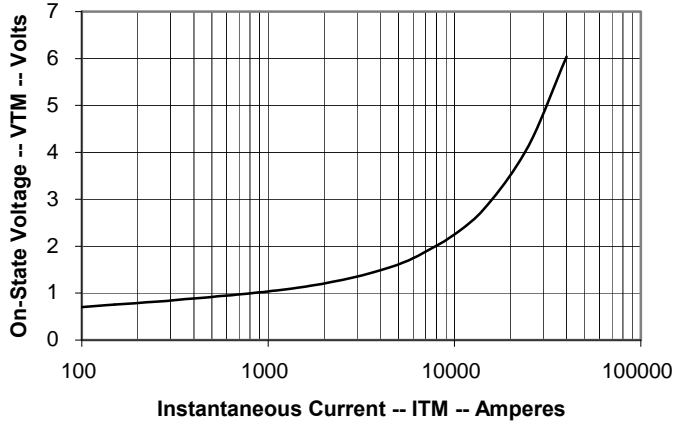

**Maximum Transient Thermal Impedance**

(Junction to Case)

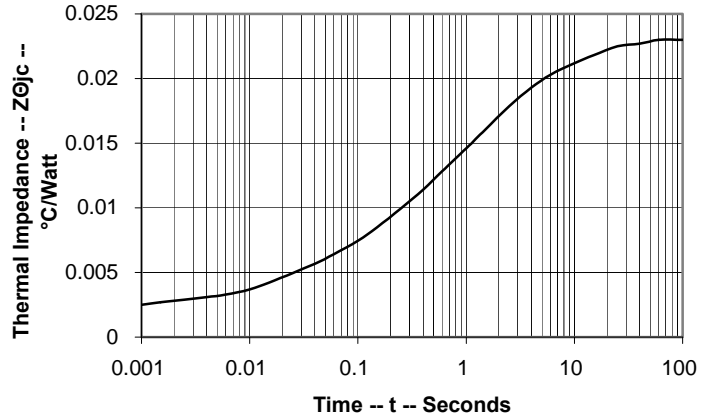

**Maximum On-State Power Dissipation**

(Sinusoidal Waveform)

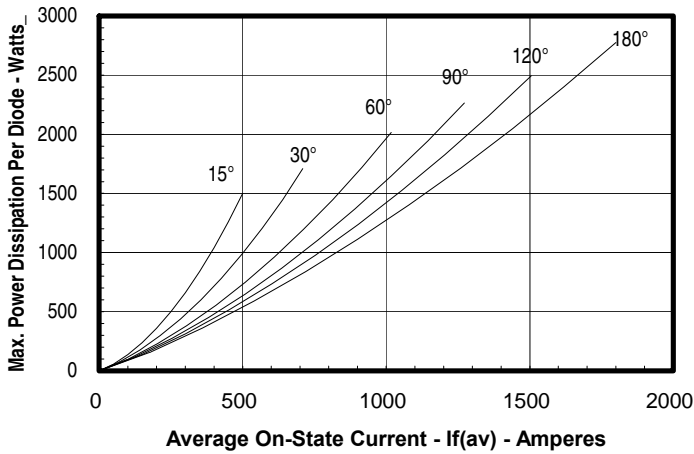

**Maximum Allowable Case Temperature**

(Sinusoidal Waveform)

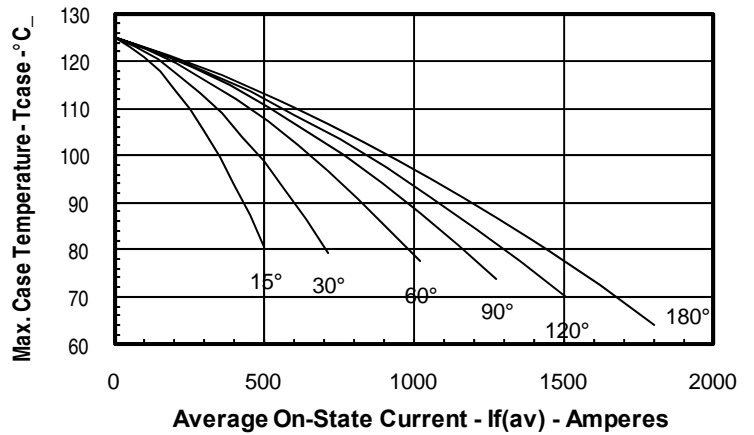

**Maximum On-State Power Dissipation**

(Rectangular Waveform)

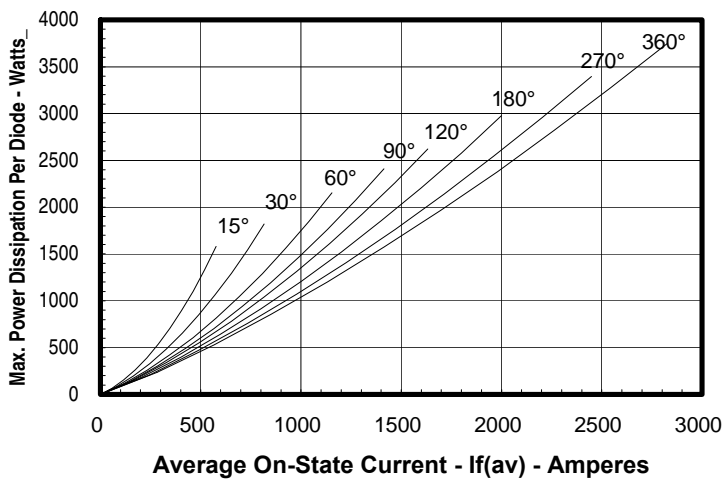

**Maximum Allowable Case Temperature**

(Rectangular Waveform)

