

SECURITY CODE

MITSUBISHI ELECTRIC CORPORATION

Spec. NAME	Prepared by	I.Umezaki	REV	A	K.Kurachi				
Customer's Std. Spec.	Checked by	Y.konishi							
	Approved by	M.Yamamoto				I.Umezaki			
	DATE	Oct.6.2003				Nov.-18-2008			

HIGH VOLTAGE DIODE MODULE SPECIFICATION

1. Type Number RM600HE-90S
2. Structure Flat base type (Insulated package, AlSiC base plate)
3. Application & Customer High power converters & Inverters
4. Outline See Fig. 1
5. Related Specifications

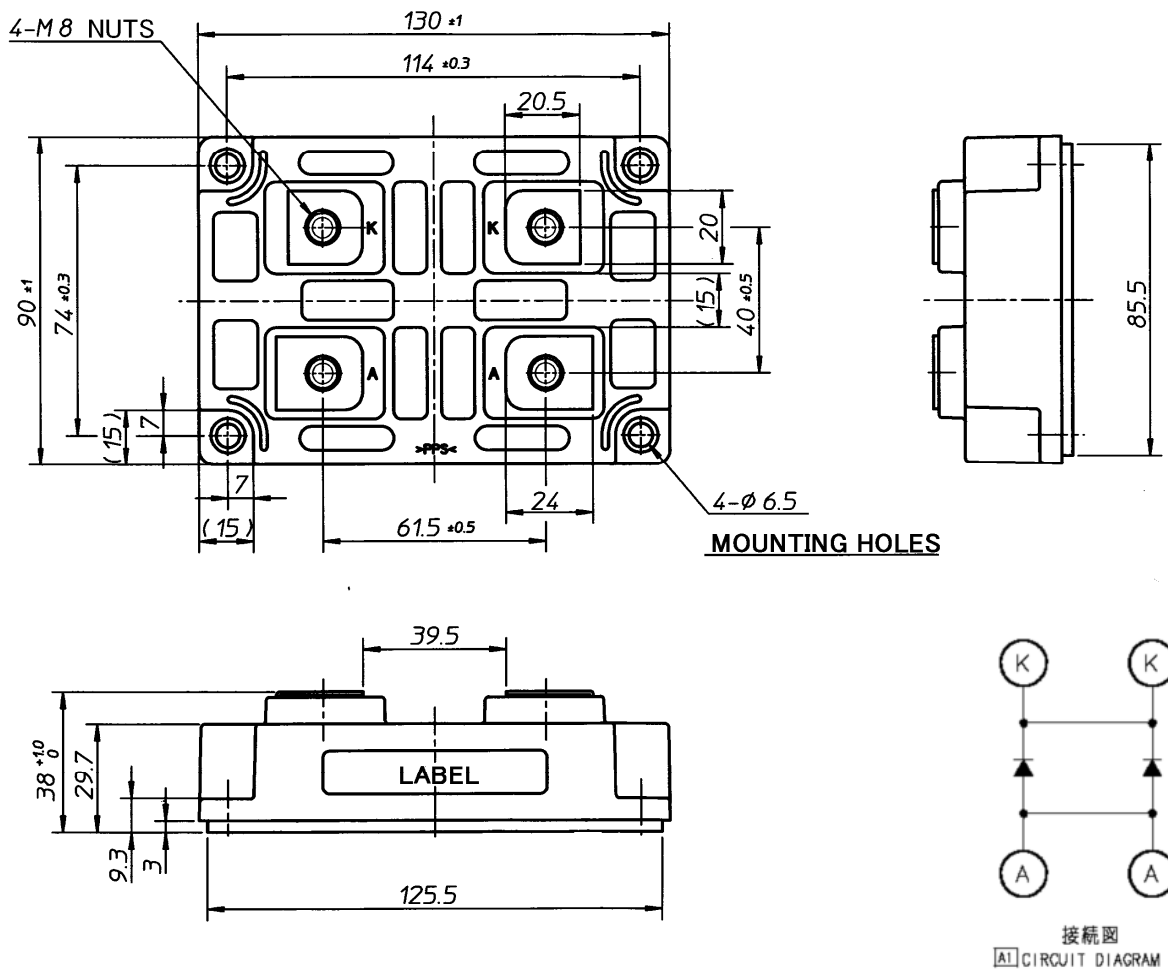

Fig. 1 - Outline drawing

6. Maximum Ratings

Item	Symbol	Conditions	Ratings	Unit
6.1 Repetitive peak reverse voltage	V_{RRM}	$T_j = 25\text{ }^\circ\text{C}$	4500	V
6.2 Non-repetitive peak reverse voltage	V_{RSM}	$T_j = 25\text{ }^\circ\text{C}$	4500	V
6.3 Reverse DC voltage	$V_{R(DC)}$	$T_j = 25\text{ }^\circ\text{C}$	3000	V
6.4 DC forward current	I_F	$T_c = 25\text{ }^\circ\text{C}$	600	A
6.5 Surge forward current	I_{FSM}	$T_j = 25\text{ }^\circ\text{C}$ start, $t_w = 8.3\text{ ms}$ Half sign wave	4800	A
6.6 Surge current load integral	I^2t	$T_j = 25\text{ }^\circ\text{C}$ start, $t_w = 8.3\text{ ms}$ Half sign wave	95.6	kA^2s
6.7 Isolation voltage	V_{iso}	Charged part to the baseplate RMS sinusoidal, 60Hz 1min.	6000	V
6.8 Junction temperature	T_j	—	-40 ~ +150	$^\circ\text{C}$
6.9 Storage temperature	T_{stg}	—	-40 ~ +125	$^\circ\text{C}$
6.10 Operating temperature	T_{op}	—	-40 ~ +125	$^\circ\text{C}$
6.11 Maximum reverse recovery instantaneous power	—	$V_R \leq 3000\text{ V}$ $di/dt \leq 2000\text{ A}/\mu\text{s}$, $T_j = 125\text{ }^\circ\text{C}$ [See Fig.1, Fig.2, 12-5]	600	kW

7. Electrical Characteristics

Item	Symbol	Conditions	Limits			Unit	
			Min.	Typ.	Max.		
7.1 Repetitive reverse current	I_{RRM}	$V_{RM} = V_{RRM}$	$T_j = 25\text{ }^\circ\text{C}$	—	—	5	mA
			$T_j = 125\text{ }^\circ\text{C}$	—	—	30	
7.2 Forward voltage	V_{FM}	$I_F = 600\text{ A}$	$T_j = 25\text{ }^\circ\text{C}$	—	4.80	—	V
			$T_j = 125\text{ }^\circ\text{C}$	—	4.20	—	
7.3 Reverse recovery time	t_{rr}	$V_R = 2250\text{ V}$, $I_F = 600\text{ A}$ $di/dt = -1400\text{ A}/\mu\text{s}$ $T_j = 125\text{ }^\circ\text{C}$ [See Fig.1, Fig.2]	—	0.90	1.8	μs	
7.4 Reverse recovery charge	Q_{rr}		—	600	—	μC	
7.5 Reverse recovery energy	E_{rec}		—	0.62	—	J/P	

Note 1: It doesn't include the voltage drop by Internal lead resistance.

8. Thermal Characteristics

Item	Symbol	Conditions	Limits			Unit
			Min.	Typ.	Max.	
8.1 Thermal resistance	$R_{th(j-c)R}$	Junction to case	—	—	39.0	K/kW
8.2 Contact thermal resistance	$R_{th(c-f)}$	Case to fin Conductive grease applied	—	15.0	—	K/kW

Note 2: Thermal conductivity is 1W/mK with a thickness of 100 μ m.

9. Mechanical Characteristics

Item	Symbol	Conditions	Limits			Unit
			Min.	Typ.	Max.	
9.1 Mounting torque	—	Main terminal screw : M8	6.67	—	13.0	N·m
9.2 Mounting torque	—	Mounting screw : M6	2.84	—	6.0	N·m
9.3 Mass	—	—	—	0.66	—	kg

10. Shipping Inspection Report Item ^(note 3)

Static characteristics : I_{RRM} [7.1], V_{FM} [7.2]

Dynamic characteristics : t_{rr} [7.3], Q_{rr} [7.4]

Note 3: One shipping inspection report with the above item values is submitted when modules are delivered. The test conditions are defined in bracket.

11. Test Circuit & Definition of Switching Characteristics

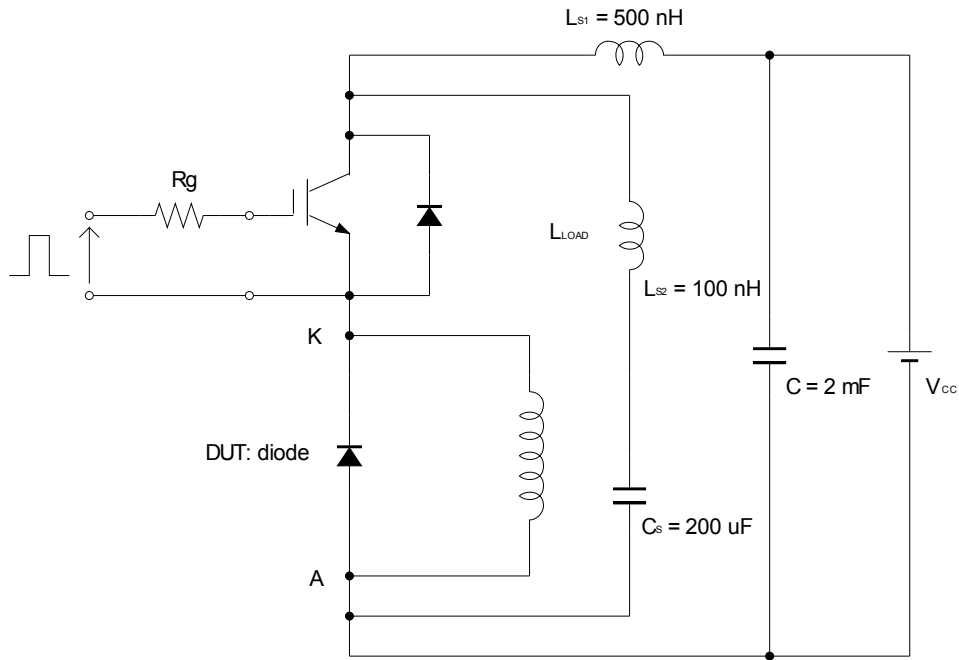
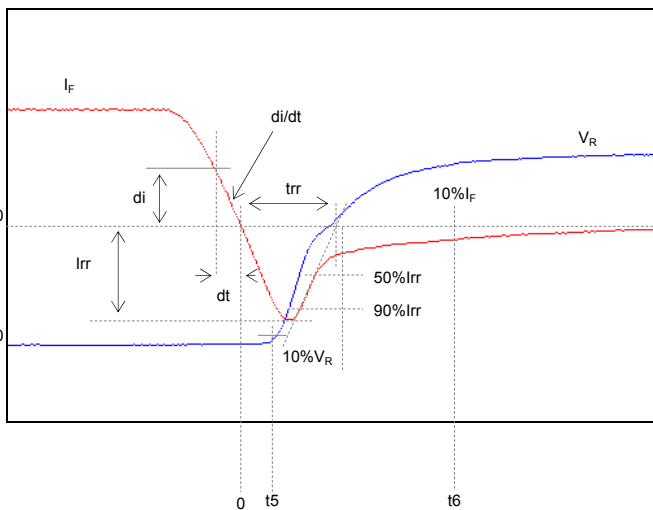

Fig. 1 – Switching test circuit

Diode part: reverse recovery



$$Q_{rr} = - \int_0^{t6} i_f dt$$

$$E_{rec} = - \int_{t5}^{t6} i_f \cdot v_r dt$$

Fig. 2 – Definitions of reverse recovery charge & energy

12. Performance curves

12-1 Forward characteristics 6

12-2 Reverse recovery energy characteristics 7

12-3 Reverse recovery current characteristics 8

12-4 Transient thermal impedance characteristics 9

12-5 Reverse recovery safe operating area 10

12-1 Forward characteristics

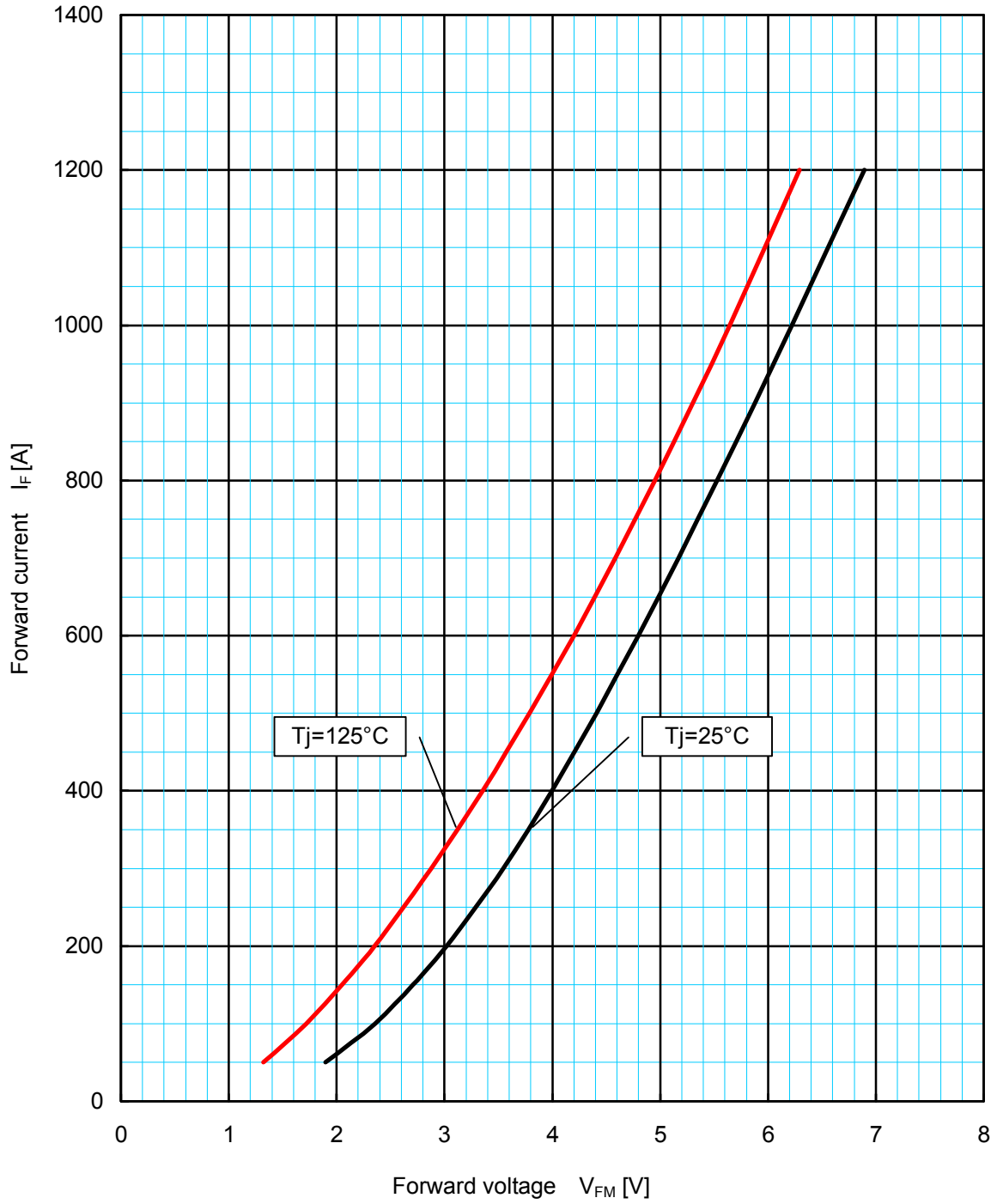

Forward voltage characteristics (typical)

12-2 Reverse recovery energy characteristics

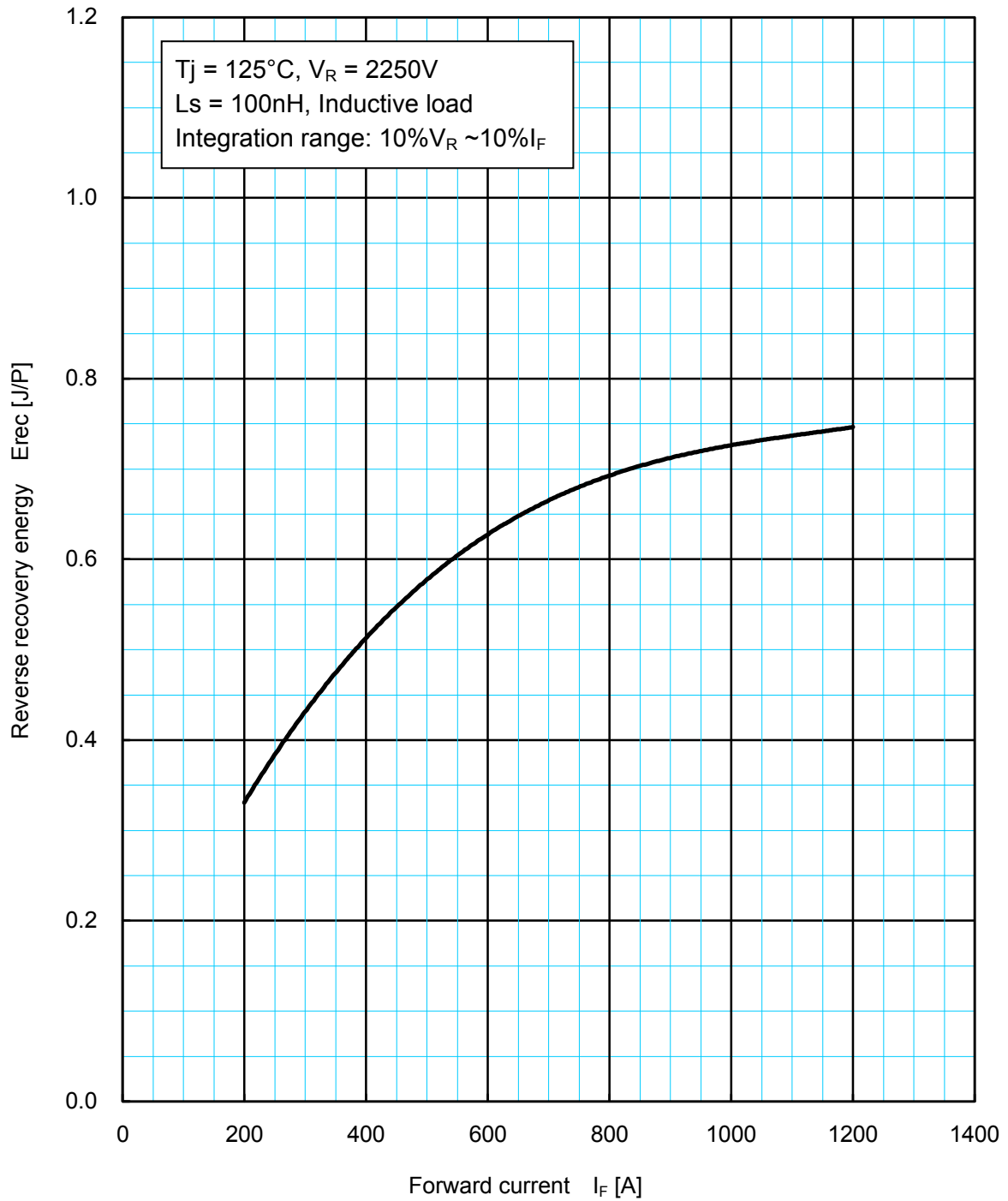

Reverse recovery energy characteristics (typical)

12-3 Reverse recovery current characteristics

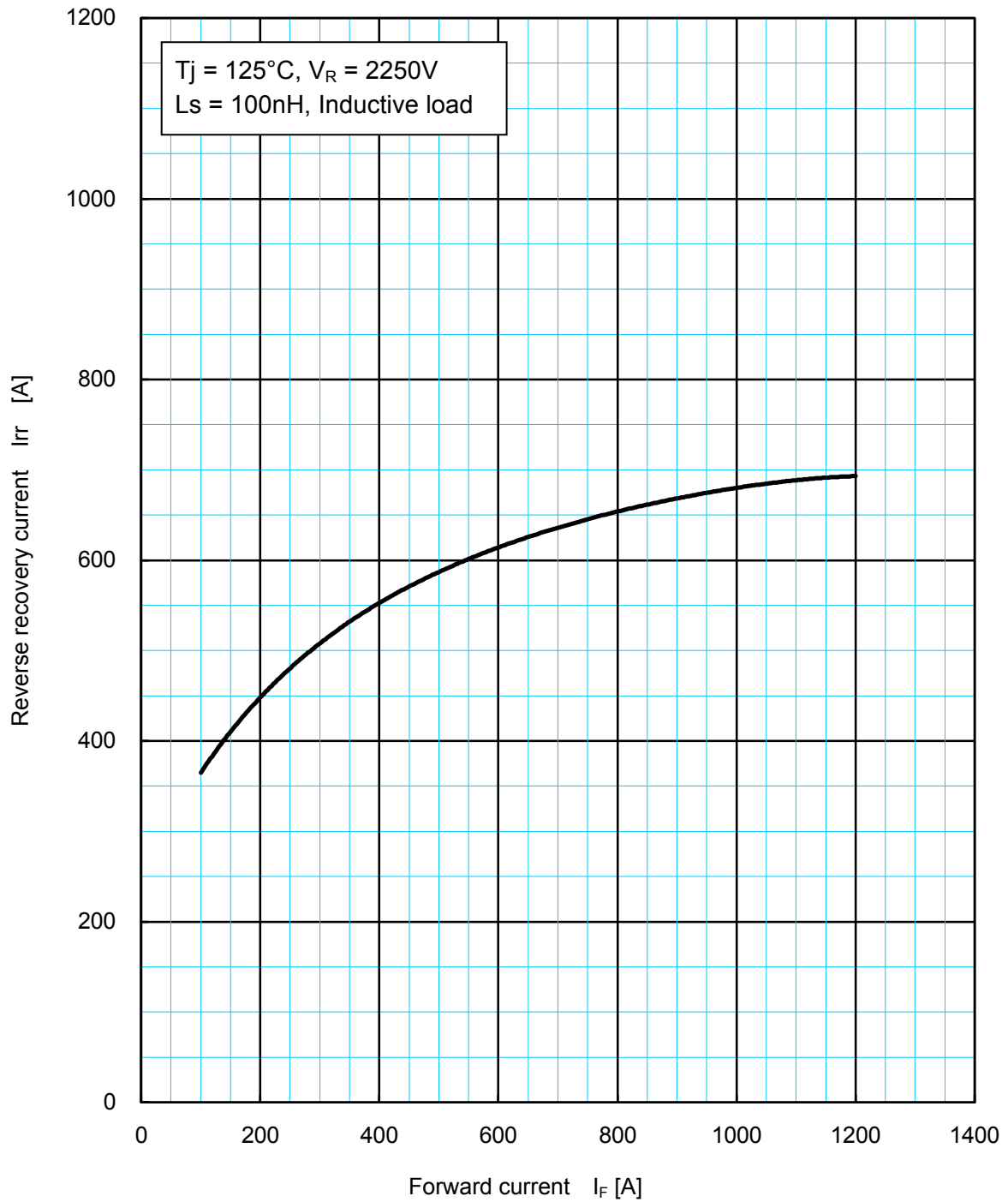

Reverse recovery current characteristics (typical)

12-4 Transient thermal impedance characteristics

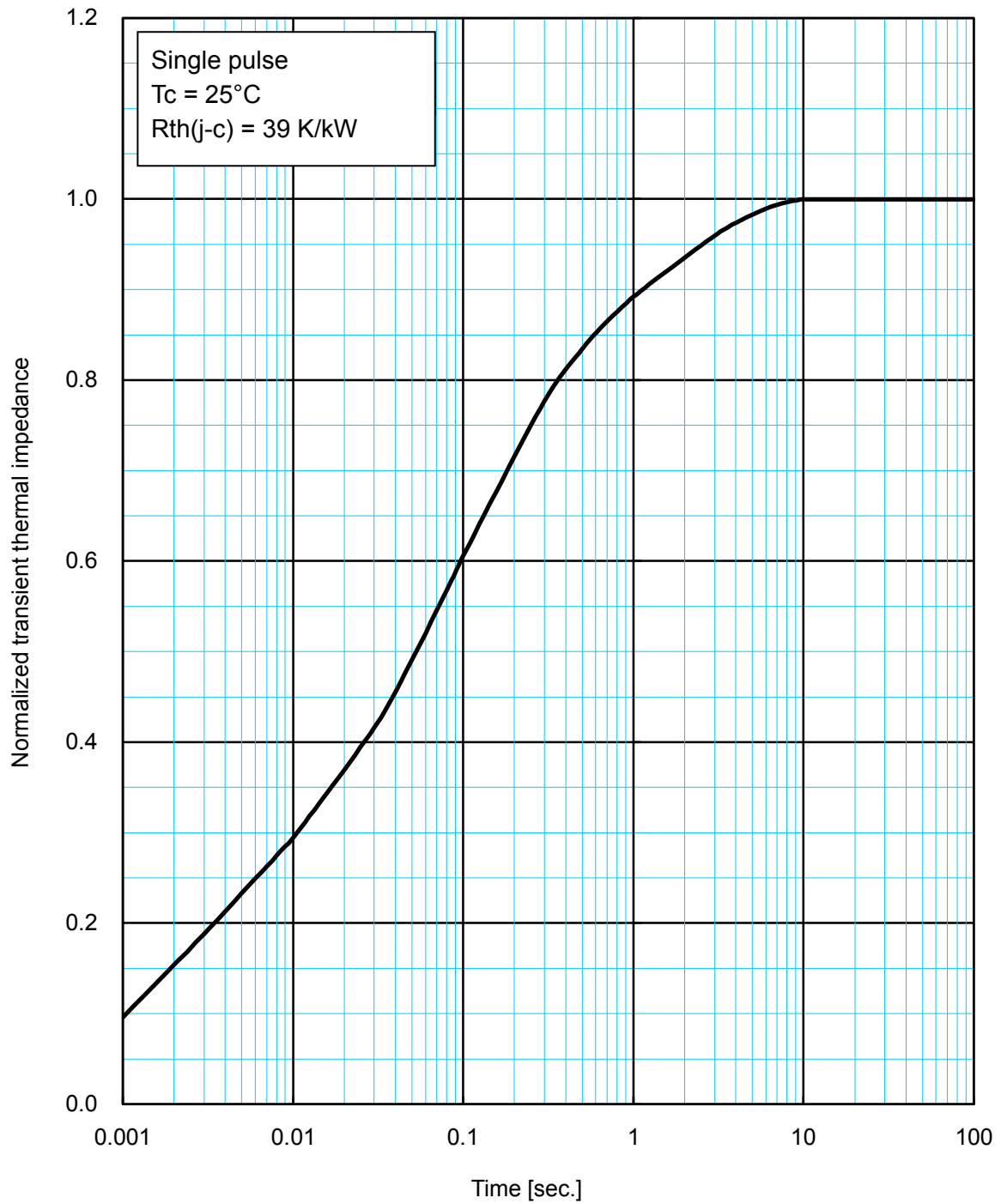

Transient thermal impedance characteristics

12-5 Reverse recovery safe operating area

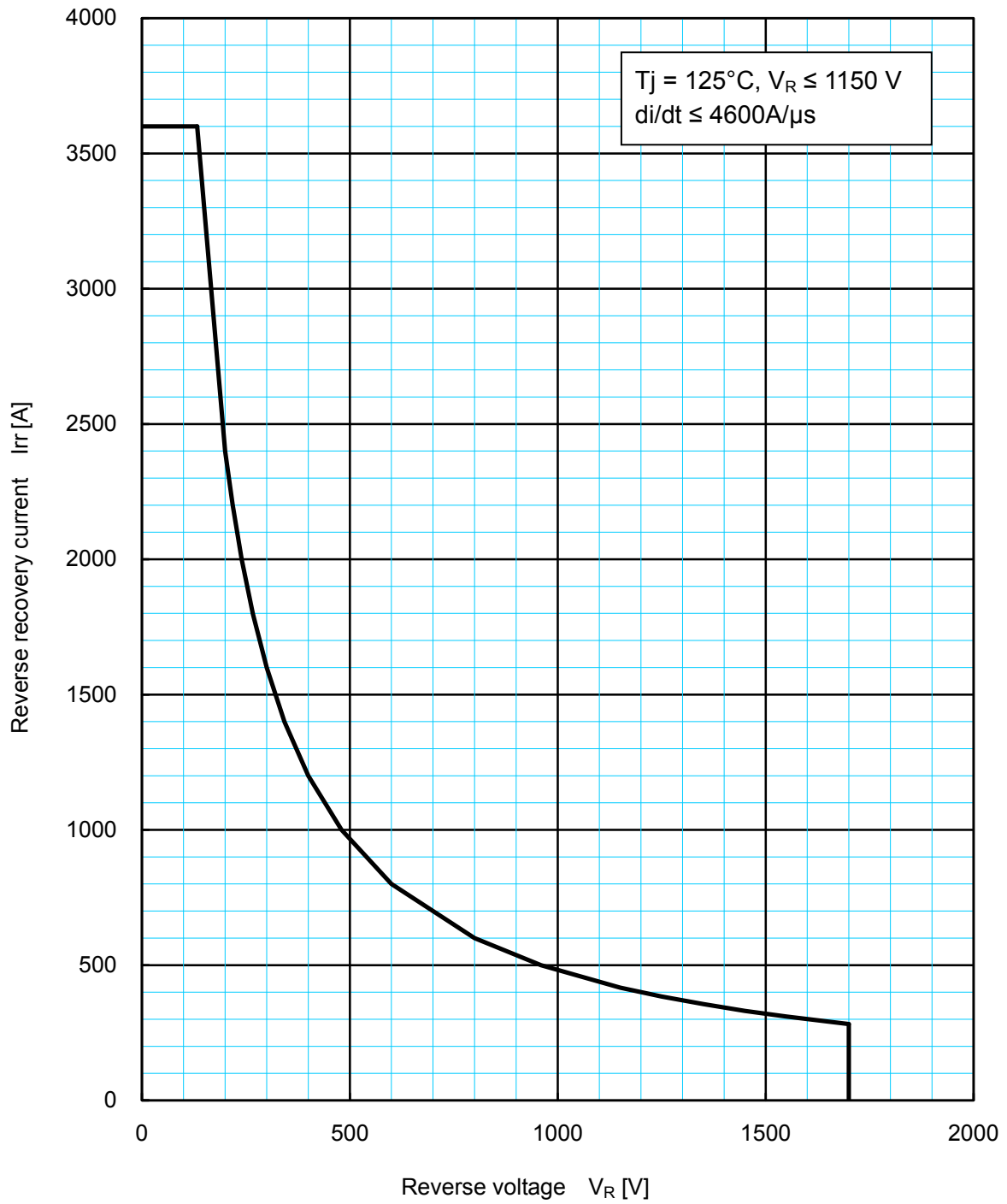

Reverse recovery safe operating area (RRSOA)

MITSUBISHI ELECTRIC CORPORATION

Rev. No.	Summary of changes	Signature & date
-	Original	I.Umezaki Oct.6.2003
A		K.Kurachi Nov.-17-2008