

RM600DY-66S

HIGH POWER SWITCHING USE
INSULATED TYPE

HVDi (High Voltage Diode) Module

RM600DY-66S



- IDC600A
- VRRM 3300V
- Insulated type
- 2-element in a pack

APPLICATION

3-level inverters, 3-level converters, DC choppers.

OUTLINE DRAWING & CIRCUIT DIAGRAM

Dimensions in mm

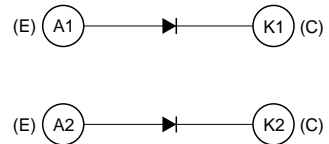
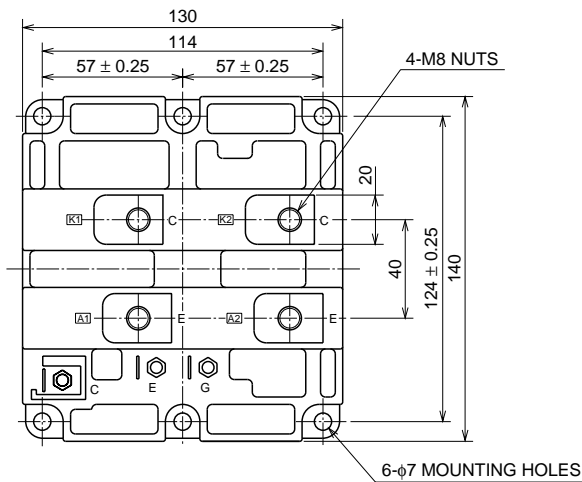

CIRCUIT DIAGRAM

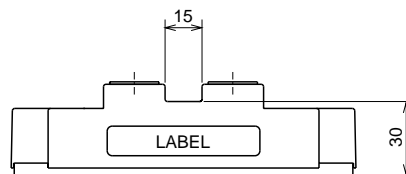
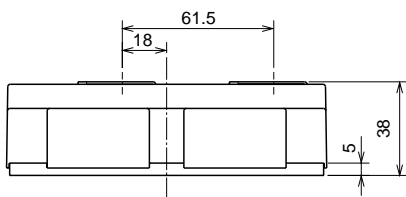

RM600DY-66S

**HIGH POWER SWITCHING USE
INSULATED TYPE**

HVDi (High Voltage Diode) Module

ABSOLUTE MAXIMUM RATINGS (T_j = 25°C)

Symbol	Item	Voltage class		Unit
		66		
VRRM	Repetitive peak reverse voltage	3300		V
VRSM	Non-repetitive peak reverse voltage	3300		V
VR(DC)	Reverse DC voltage	2200		V

Symbol	Item	Conditions	Ratings	Unit
I _{DC}	Output DC current	T _c = 25°C	600	A
I _{FSM}	Surge (non-repetitive) forward current	1 cycle of half wave 60Hz, peak value, non-repetitive, T _j = 25°C start, V _{RM} = 0V	4800	A
I ² _t	I ² _t for fusing	Value of one cycle surge current, tw = 8.3ms, T _j = 25°C start	9.60 × 10 ⁴	A ² s
T _j	Junction temperature	—	-40 ~ +150	°C
T _{stg}	Storage temperature	—	-40 ~ +125	°C
V _{iso}	Isolation Voltage	Charged part to base plate, rms, sinusoidal, AC 60Hz 1min.	6000	V
—	Mounting torque	Main terminals screw M8	6.67 ~ 13.00	N · m
—		Mounting screw M6	2.84 ~ 6.00	N · m
—	Mass	Typical value	1.5	kg

ELECTRICAL CHARACTERISTICS (T_j = 25°C)

Symbol	Item	Test conditions	Limits			Unit
			Min	Typ	Max	
I _{RRM}	Repetitive reverse current	VRRM applied, V _{RM} = VRRM	—	—	4	mA
V _{FM}	Forward voltage	I _{FM} = 600A	—	3.50	4.55	V
t _{rr}	Reverse recovery time	I _{FM} = 600A, di/dt = -1200A/μs,	—	—	1.20	μs
Q _{rr}	Reverse recovery charge	V _R = 1650V	—	150	—	μC
R _{th(j-c)}	Thermal resistance	Junction to case (Per 1/2 module)	—	—	0.048	K/W
R _{th(c-f)}	Contact thermal resistance	Case to fin, conductive grease applied (Per 1/2 module)	—	0.024	—	K/W

RM600DY-66S

**HIGH POWER SWITCHING USE
INSULATED TYPE**

HVDi (High Voltage Diode) Module

PERFORMANCE CURVES

81.563

