

Super Fast Recovery Dual Diode Module 300 Amperes/1200 Volts

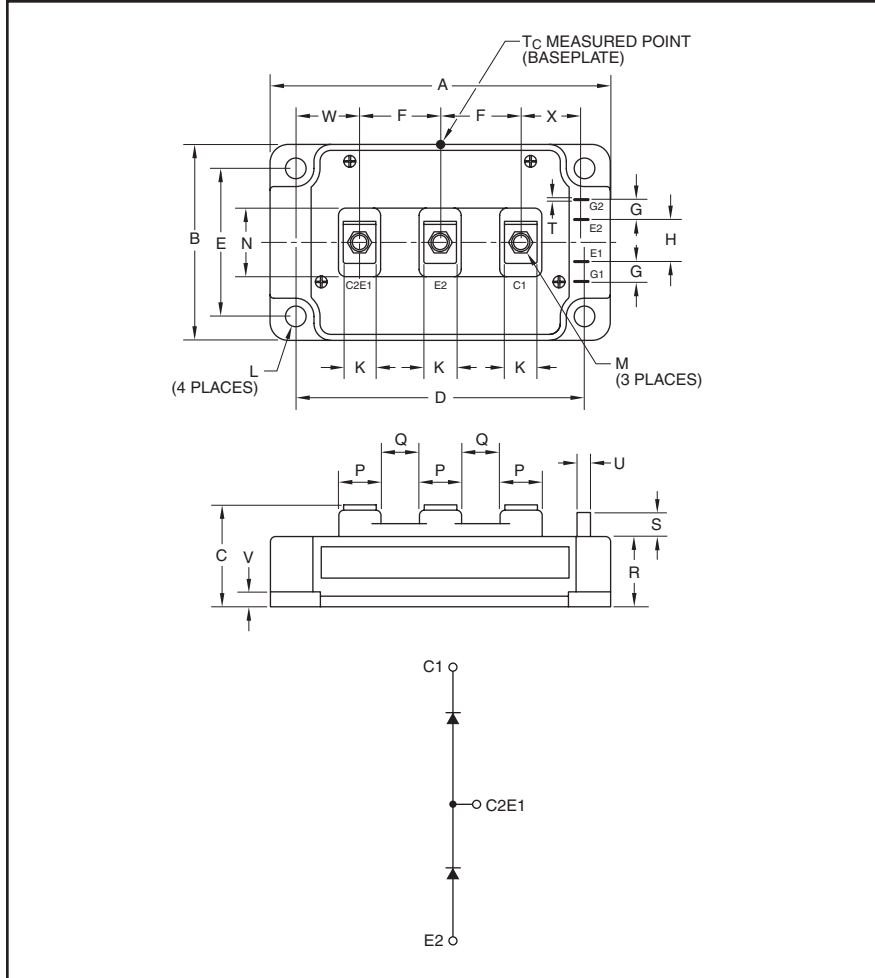

Description:

Powerex Super Fast Recovery Dual Diode Modules are designed for use in applications requiring fast switching. The modules are isolated for easy mounting with other components on common heatsinks.

Features:

- Isolated Mounting
- Planar Chips

Applications:

- Inverters
- Choppers
- Switching Power Supplies
- Free-Wheeling

Outline Drawing and Circuit Diagram

Dimensions	Inches	Millimeters
A	4.25	108.0
B	2.44	62.0
C	1.18+0.04/-0.02	30.0+1.0/-0.5
D	3.66±0.01	93.0±0.25
E	1.89±0.01	48.0±0.25
F	0.98	25.0
G	0.24	6.0
H	0.59	15.0
K	0.55	14.0
L	0.26 Dia.	6.5 Dia.
M	M6 Metric	M6

Dimensions	Inches	Millimeters
N	1.18	30.0
P	0.71	18.0
Q	0.28	7.0
R	0.87	22.2
S	0.33	8.5
T	0.02	0.5
U	0.110	2.8
V	0.16	4.0
W	0.85	21.5
X	0.94	24.0

Ordering Information:

Select the complete ten digit module part number you desire from the table below. Example: RM300DY1-24S is a 1200V, 300 Ampere, Super Fast Recovery Dual Diode Module.

Type	Current Rating Amperes	V _{CEs} Volts (x 100)
RM	300	12

RM300DY1-24S
Super Fast Recovery Dual Diode Module
 300 Amperes/1200 Volts

Absolute Maximum Ratings, $T_j = 25\text{ }^\circ\text{C}$ unless otherwise specified

Ratings	Symbol	RM300DY1-24S	Units
Junction Temperature	T_j	-40 to 150	$^\circ\text{C}$
Storage Temperature	T_{stg}	-40 to 125	$^\circ\text{C}$
Repetitive Peak Reverse Voltage	V_{rrm}	1200	Volts
Non-repetitive Peak Reverse Voltage	V_{rsm}	1200	Volts
DC Reverse Voltage	$V_{r(DC)}$	960	Volts
Forward Current	I_{DC}	300	Amperes
Mounting Torque, M6 Main Terminal	—	40	in-lb
Mounting Torque, M6 Mounting	—	40	in-lb
Weight	—	400	Grams
Isolation Voltage (Main Terminal to Baseplate, AC 1 min.)	V_{ISO}	2500	Volts

Static Electrical Characteristics, $T_j = 25\text{ }^\circ\text{C}$ unless otherwise specified

Characteristics	Symbol	Test Conditions	Min.	Typ.	Max.	Units
Repetitive Peak Reverse Current	I_{rrm}	$V_{rm} = V_{rrm}, T_j = 150\text{ }^\circ\text{C}$	—	—	10	mA
Forward Voltage Drop	V_{FM}	$I_{FM} = 300\text{A}, t_w \leq 1\text{ms}, T_j = 25\text{ }^\circ\text{C}$	—	—	3.5	Volts
Reverse Recovery Time	t_{rr}	$V_{CC} = 600\text{V}, I_F = 300\text{A}, T_j = 25\text{ }^\circ\text{C},$ $dI_F/dt = -6000\text{A}/\mu\text{s},$	—	—	250	ns
Reverse Recovery Charge	Q_{rr}	$V_{GE1} = V_{GE2} = 15\text{V}, R_G = 1\Omega$ Inductive Load Switching	—	13	—	μC
Thermal Resistance, Junction to Case	$R_{th(j-c)}$	Per IGBT 1/2 Module T_C and T_f Measured Just Under Chips	—	—	0.12	$^\circ\text{C}/\text{W}$
Contact Thermal Resistance, Case to Fin*	$R_{th(c-f)}$	Per 1/2 Module, Thermal Grease Applied T_C and T_f Measured Just Under Chips	—	0.04	—	$^\circ\text{C}/\text{W}$

*Typical value is measured by using Shin-Etsu Chemical Co., Ltd. "G746"

