

**General Purpose Rectifier  
1200 Amperes Average  
2400 Volts**

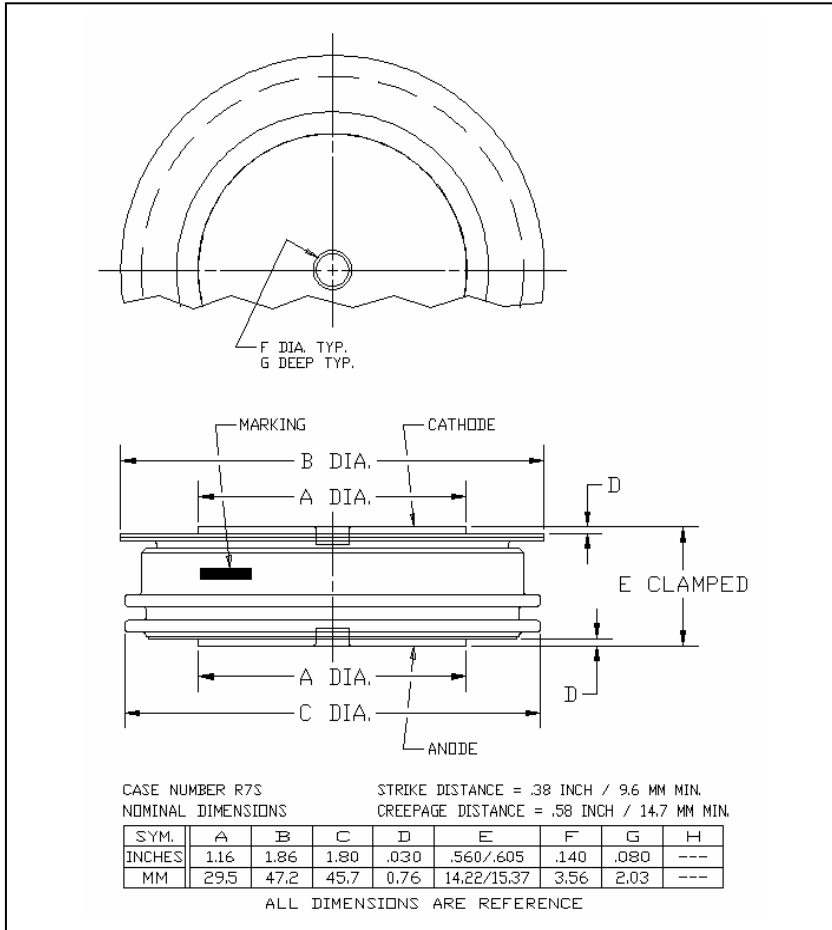

**R7S0 1200A (Outline Drawing)**

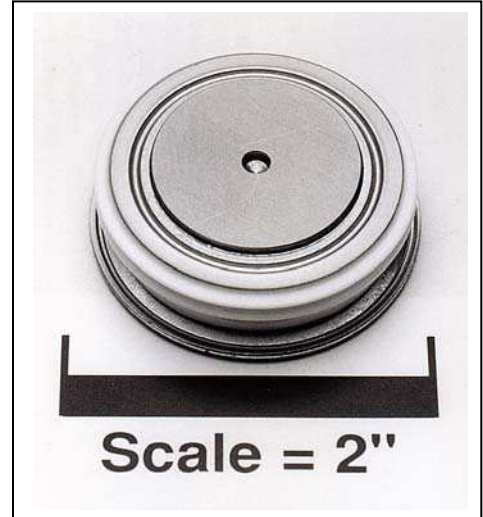

**R7S0 1200A General Purpose Rectifier  
1200 Amperes Average, 2400 Volts**

**Description:**

Powerex General Purpose Rectifiers are designed for high blocking voltage capability with low forward voltage to minimize conduction losses. The hermetic Pow-R-Disc devices can be mounted using commercially available clamps and heatsinks.

**Features:**

- Low Forward Voltage
- Low Thermal Impedance
- Low Profile Package
- Hermetic Packaging
- Excellent Surge and  $I^2t$  Ratings

**Applications:**

- Power Supplies
- Motor Control
- Free Wheeling Diode
- Battery Chargers
- Resistance Welding

**Ordering Information:**

Select the complete eight digit module part number from the table below.  
Example: R7S01812XX is a 1800V 1200 A General Purpose Rectifier

Type	Voltage $V_{RRM}$ (Volts)	Current $I_{T(av)}$ (A)	Typical Recovery Time $t_{RR}$ ( $\mu$ sec)
R7S0	18 through 24	12	XX
	1800V through 2400V	1200A	10 $\mu$ sec typical

**Absolute Maximum Ratings**

Characteristics	Symbol		Units
Non-Repetitive Transient Peak Reverse Blocking Voltage	$V_{RSM}$	$V_{RRM} + 200V$	Volts
RMS Forward Current, $T_C = 86^\circ C$	$I_{F(RMS)}$	1875	Amperes
Average Current 180° Sine Wave, $T_C = 86^\circ C$	$I_{F(AV)}$	1200	Amperes
RMS Forward Current, $T_C = 55^\circ C$	$I_{F(RMS)}$	2355	Amperes
Average Current 180° Sine Wave, $T_C = 86^\circ C$	$I_{F(AV)}$	1500	Amperes
Peak One Cycle Surge Forward Current (Non-Repetitive) 60 Hz	$I_{FSM}$	9000	Amperes
Peak One Cycle Surge Forward Current (Non-Repetitive) 50 Hz	$I_{FSM}$	8200	Amperes
3 Cycle Surge Current	$I_{FSM}$	6485	Amperes
10 Cycle Surge Current	$I_{FSM}$	5600	Amperes
$I^2t$ (for Fusing) for One Cycle, 60 Hz	$I^2t$	337,500	$A^2 \text{ sec}$
Maximum $I^2t$ of Package ( $t = 8.3 \text{ msec}$ )	$I^2t$	$80 \times 10^6$	$A^2 \text{ sec}$
Operating Temperature	$T_J$	-65 to +175	$^\circ C$
Storage Temperature	$T_{stg}$	-65 to +200	$^\circ C$
Approximate Weight		4	oz.
		113	g
Mounting Force		2000 to 2400	lb.
		900 to 1090	kg.

**Electrical Characteristics,  $T_J=25^\circ\text{C}$  unless otherwise specified**

Characteristics	Symbol	Test Conditions	Min.	Max.	Units
Repetitive Peak Reverse Leakage Current	$I_{RRM}$	$T_J=125^\circ\text{C}$ , $V_R = V_{RRM}$		50	mA
Peak On-State Voltage	$V_{FM}$	$I_{FM}=1500\text{A}$ , Duty Cycle < 0.1 %		1.60	V
Threshold Voltage	$V_{(TO)}$	$T_J = 175^\circ\text{C}$ , $I = 15\%I_{F(AV)}$ to $I_{FSM}$		0.831	V
Slope Resistance	$r_T$			0.441	$\text{m}\Omega$
$V_{TM}$ Coefficients, Full Range		$T_J = 175^\circ\text{C}$ , $I = 15\%I_{F(AV)}$ to $I_{FSM}$	A =	1.585	
			B =	-0.216	
		$V_{FM} = A + B \ln I + C I + D \text{ Sqrt } I$	C =	2.00 E-4	
			D =	0.0308	
Diode Reverse Recovery Time (Typical)	$t_{rr}$	$T_C = 25^\circ\text{C}$ , $I_{fm} = 1500\text{A}$ , $di_R/dt = -25\text{A}/\mu\text{s}$ , $T_p = 190 \mu\text{s}$		10 (Typical)	$\mu\text{s}$

**Thermal Characteristics**

Maximum Thermal Resistance, Double Sided Cooling		Max.	Units
Junction-to-Case	$R_{\Theta(J-C)}$	0.035	$^\circ\text{C}/\text{W}$
Case-to-Sink	$R_{\Theta(C-S)}$	0.02	$^\circ\text{C}/\text{W}$

**Maximum On-State Forward Voltage Drop  
(T<sub>j</sub> = 175 °C)**

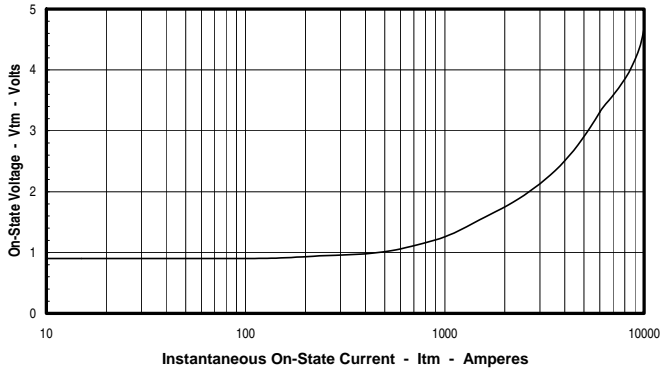

**Maximum Transient Thermal Impedance  
(Junction to Case)**

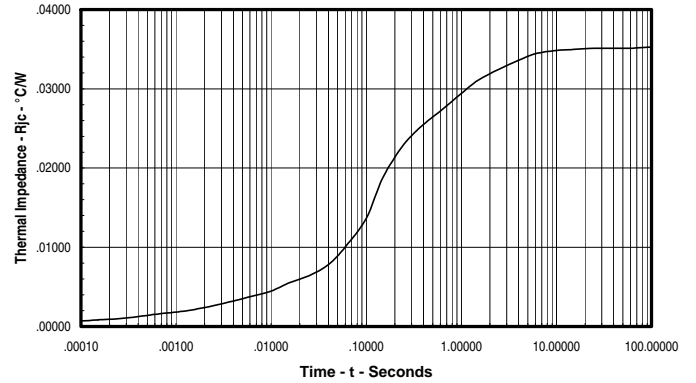

**Maximum On-State Power Dissipation  
(Sinusoidal Waveform)**

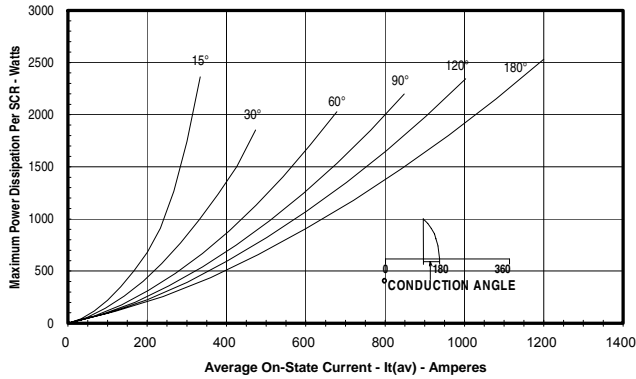

**Maximum Allowable Case Temperature  
(Sinusoidal Waveform)**

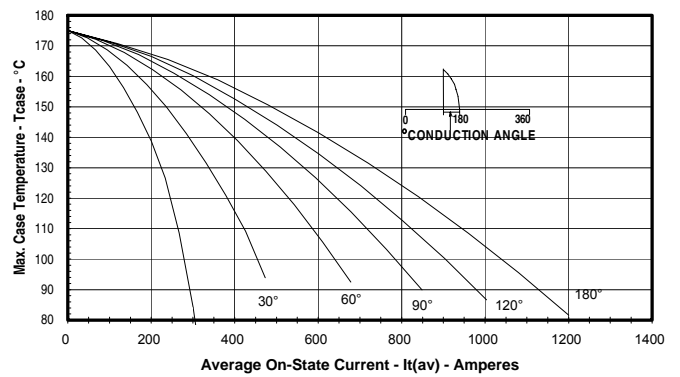

**Maximum On-State Power Dissipation  
(Rectangular Waveform)**

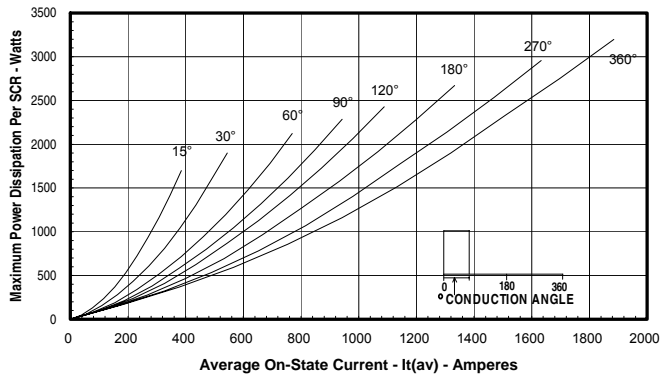

**Maximum Allowable Case Temperature  
(Rectangular Waveform)**

