

Super Fast Recovery Diode Modules 140 Amperes/1200 Volts

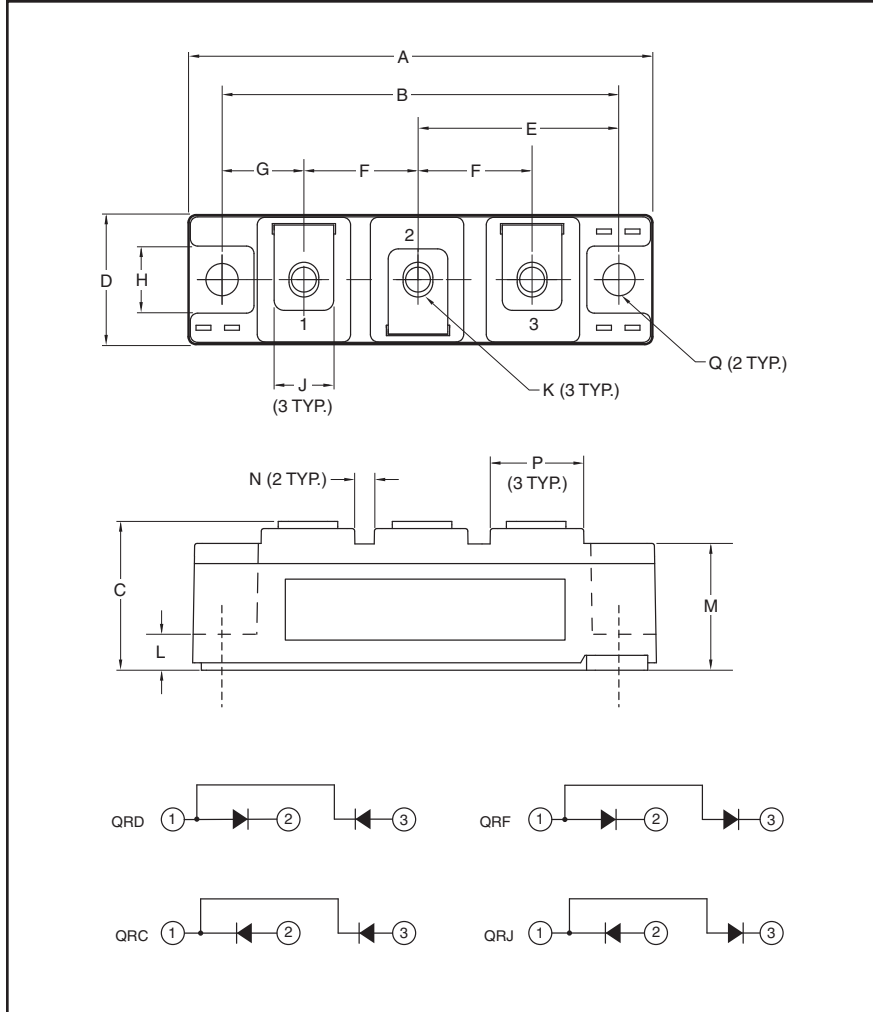

Description:

Powerex Super Fast Recovery Dual Diode Modules are designed for use in applications requiring fast switching. The modules are isolated for easy mounting with other components on common heatsinks.

Features:

- Super Fast Recovery Time
- RoHS Compliant
- Isolated Mounting
- Metal Baseplate
- Low Thermal Impedance
- 2500V Isolating Voltage

Applications:

- Free Wheeling
- Welding and Plasma Cutting Machine

Outline Drawing and Circuit Diagram

Dimensions	Millimeters
A	93.5
B	80
C	30
D	26
E	40.5
F	23
G	16.5
H	13

Dimensions	Millimeters
J	12
K	M5
L	7.5
M	25.4
N	4
P	19
Q	6.5 Dia.

QR_1220R30
Super Fast Recovery Dual Diode Modules
 140 Amperes/1200 Volts

Absolute Maximum Ratings, $T_j = 25\text{ }^\circ\text{C}$ unless otherwise specified

Ratings	Symbol	QRD1220R30 QRC1220R30 QRF1220R30 QRJ1220R30	Units
Repetitive Peak Reverse Blocking Voltage	V_{RRM}	1200	Volts
Non-Repetitive Peak Reverse Blocking Voltage	V_{RSM}	$V_{RRM} + 100$	Volts
DC Current, $T_C = 80^\circ\text{C}$ (Resistive Load)	$I_{F(DC)}$	140	Amperes
Peak Half Cycle Non-repetitive Surge Current ($t = 8.3\text{mS}$, 100% V_{RRM} Reapplied)	I_{FSM}	TBD	Amperes
I^2t for Fusing for One Cycle ($t = 8.3\text{mS}$, 100% V_{RRM} Reapplied)	I^2t	TBD	A^2sec
Operating Junction Temperature	T_j	-40 to 150	$^\circ\text{C}$
Storage Temperature	T_{stg}	-40 to 125	$^\circ\text{C}$
Maximum Mounting Torque, M6 Mounting Screw	—	26	in-lb
Maximum Mounting Torque, M5 Terminal Screw	—	17	in-lb
Module Weight (Typical)	—	150	Grams
V Isolation (60 Hz, Circuit to Base, All Terminals Shorted, $t = 60\text{ sec}$)	V_{RMS}	2500	Volts

Electrical Characteristics, $T_j = 25\text{ }^\circ\text{C}$ unless otherwise specified

Characteristics	Symbol	Test Conditions	Min.	Typ.	Max.	Units
Reverse Leakage Current	I_{RRM}	Rated V_{RRM}	—	—	1.0	mA
On-State Voltage	V_{FM}	$I_F = 100\text{A}$	—	2.4	3.2	Volts
		$I_F = 140\text{A}$	—	2.7	3.5	Volts
Reverse Recovery Time	t_{rr}	$I_f = 100\text{A}$, $di/dt = \text{TBD}$	—	—	150	ns
Reverse Recovery Charge	Q_{rr}	$I_f = 100\text{A}$, $di/dt = \text{TBD}$	—	9.6	—	μC

Thermal and Mechanical Characteristics, $T_j = 25\text{ }^\circ\text{C}$ unless otherwise specified

Characteristics	Symbol	Test Conditions	Min.	Typ.	Max.	Units
Thermal Resistance, Junction to Case*	$R_{th(j-c)}$ Q	Per Diode	—	—	0.15	$^\circ\text{C/W}$
Contact Thermal Resistance, Case to Sink (Lubricated)*	$R_{th(c-s)}$	Per Module	—	—	0.075	$^\circ\text{C/W}$

* T_C , T_f measured point is just under the chip.

QR_1220R30
Super Fast Recovery Dual Diode Modules
 140 Amperes/1200 Volts

