

Single MOSFET Module 120 Amperes/500 Volts

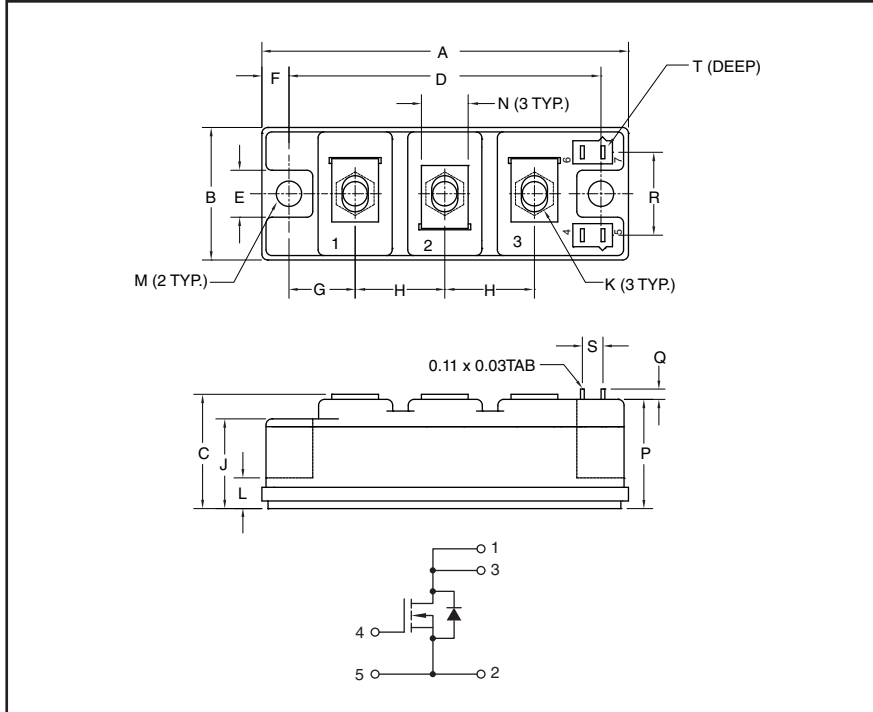

Outline Drawing and Circuit Diagram

Dimensions	Inches	Millimeters
A	3.70	94.0
B	1.34	34.0
C	1.18	30.0
D	3.15	80.0
E	0.50	12.7
F	0.28	7.0
G	0.67	17.0
H	0.91	23.0
J	0.91	23.0

Dimensions	Inches	Millimeters
K	M6 Metric	M6
L	0.31	8.0
M	0.256 Dia.	6.5 Dia.
N	0.47	12.0
P	1.13	28.7
Q	0.10	2.5
R	0.84	21.3
S	0.21	5.3
T	0.24	6.1



Description:

Powerex Single MOSFET Module is designed specially for customer applications. The module is isolated for easy mounting with other components on a common heatsink.

Features:

- Typical $R_{DS(on)} = 0.022\Omega$
- High dv/dt Capabilities
- Two STY60NM50 Chips
- Isolated Mounting
- Isolation Material - DBC AlN
- Copper Baseplate



Powerex, Inc., 173 Pavilion Lane, Youngwood, Pennsylvania 15697 (724) 925-7272 www.pwr.com

QJS0512001
Single MOSFET Module
 120 Amperes/500 Volts

Maximum Ratings, $T_j = 25^\circ\text{C}$ unless otherwise specified

Ratings	Symbol	QJS0512001	Units
Drain-Source Voltage	V_{DS}	500	Volts
Drain-Gate Voltage	V_{DGR}	500	Volts
Gate-Source Voltage	V_{GS}	± 30	Volts
Drain Current (Continuous) at $T_C = 25^\circ\text{C}$	I_D	120	Amperes
Drain Current (Continuous) at $T_C = 100^\circ\text{C}$	I_D	75	Amperes
Junction Temperature	T_j	-40 to 150	$^\circ\text{C}$
Storage Temperature	T_{stg}	-40 to 125	$^\circ\text{C}$
Mounting Torque, M6 Terminal Screws	—	26	in-lb
Mounting Torque, M6 Mounting Screws	—	26	in-lb
Module Weight (Typical)	—	220	Grams
V Isolation Voltage	V_{RMS}	2500	Volts

Static Electrical Characteristics, $T_j = 25^\circ\text{C}$ unless otherwise specified

Characteristics	Symbol	Test Conditions	Min.	Typ.	Max.	Units
Drain-Source Breakdown Voltage	$V_{(BR)DSS}$	$I_D = 500\mu\text{A}, V_{GS} = 0$	500	—	—	Volts
Zero Gate Voltage Drain Current	I_{DSS}	$V_{GS} = 0, V_{DS} = 500\text{V}$	—	—	20	μA
Zero Gate Voltage Drain Current	I_{DSS}	$V_{GS} = 0, V_{DS} = 500\text{V}, T_C = 125^\circ\text{C}$	—	—	200	μA
Gate Leakage Current	I_{GSS}	$V_{DS} = 0, V_{GS} = \pm 20\text{V}$	—	—	± 20	μA
Gate Threshold Voltage	$V_{GS(th)}$	$V_{DS} = V_{GS}, I_D = 500\mu\text{A}$	3.0	4.0	5.0	Volts
Drain-Source On Resistance	$R_{DS(on)}$	$I_D = 60\text{A}, V_{GS} = 10\text{V}$	—	0.022	0.025	Ω
Total Gate Charge	Q_G	$V_{DD} = 400\text{V}, I_D = 120\text{A}, V_{GS} = 10\text{V}$	—	380	530	nC
Forward On Voltage Source-Drain Diode	V_{SD}	$I_{SD} = 120\text{A}, V_{GS} = 0$	—	—	1.5	Volts

Thermal and Mechanical Characteristics, $T_j = 25^\circ\text{C}$ unless otherwise specified

Characteristics	Symbol	Test Conditions	Min.	Typ.	Max.	Units
Thermal Resistance, Junction to Case	$R_{th(j-c)}$	MOSFET	—	0.1	TBD	$^\circ\text{C}/\text{W}$
Contact Thermal Resistance,	$R_{th(c-f)}$	Module	—	—	0.075	$^\circ\text{C}/\text{W}$
Thermal Grease Applied						