

HV Single Discrete IGBT 60 Amperes/4500 Volts

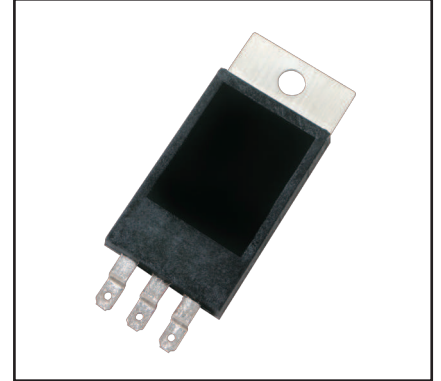
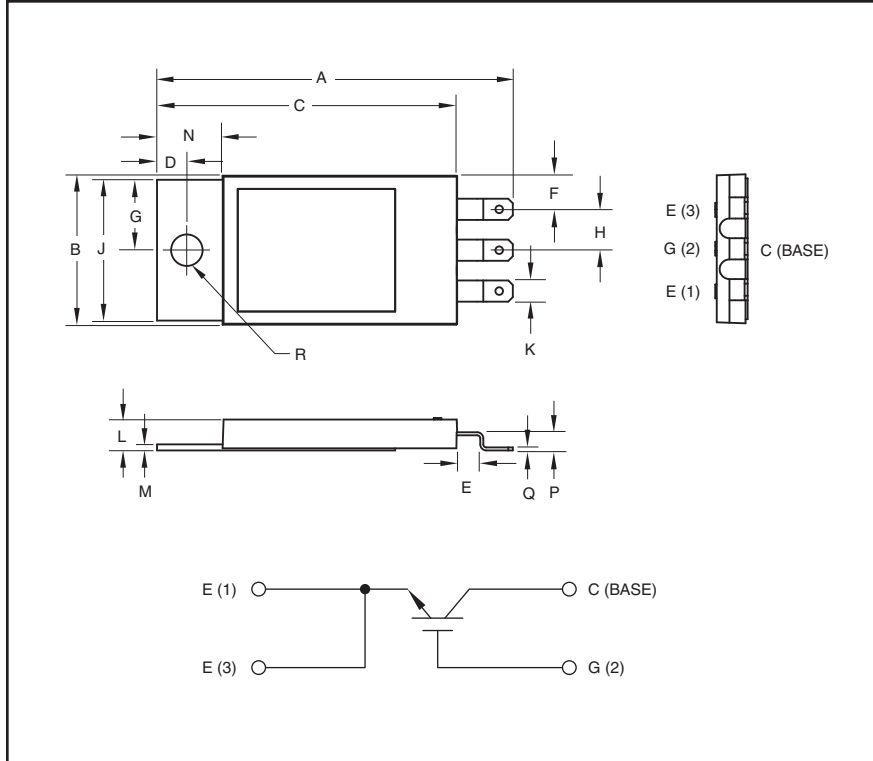

Description:

Powerex Single Non-isolated Discrete is designed specially for customer high voltage switching and pulse power applications.

Features:

- Low Drive Requirement
- Low $V_{CE(sat)}$
- Molybdenum Mounting Plate

Outline Drawing and Circuit Diagram

Dimensions	Inches	Millimeters
A	2.35	59.7
B	0.98	25.0
C	1.98	50.3
D	0.197	5.0
E	0.22	5.5
F	0.22	5.6
G	0.465	11.8
H	0.27	6.9

Dimensions	Inches	Millimeters
J	0.93	23.6
K	0.14	3.6
L	0.20	5.2
M	0.40	1.0
N	0.43	11.0
P	0.20	0.5
Q	0.12	3.0
R	0.208 Dia.	5.3 Dia.

QIS4506002
HV Single Discrete IGBT
 60 Amperes/4500 Volts

Maximum Ratings, $T_j = 25\text{ }^\circ\text{C}$ unless otherwise specified

Ratings	Symbol	QIS4506002	Units
Collector Emitter Voltage	V_{CES}	4500	Volts
Gate Emitter Voltage	V_{GES}	± 20	Volts
Collector Current (DC, $T_C = 127^\circ\text{C}$)	I_C	60	Amperes
Peak Collector Current (Pulsed)	I_{CM}	120*	Amperes
Junction Temperature	T_j	-55 to 150	$^\circ\text{C}$
Storage Temperature	T_{stg}	-55 to 125	$^\circ\text{C}$
Mounting Torque, M5 Mounting Screws	—	30	in-lb
Weight (Typical)	—	20	Grams

Static Electrical Characteristics, $T_j = 25\text{ }^\circ\text{C}$ unless otherwise specified

Characteristics	Symbol	Test Conditions	Min.	Typ.	Max.	Units
Collector Cutoff Current	I_{CES}	$V_{CE} = V_{CES}, V_{GE} = 0V$	—	—	1.0	mA
Gate Leakage Current	I_{GES}	$V_{GE} = V_{GES}, V_{CE} = 0V$	—	—	0.5	μA
Gate-Emitter Threshold Voltage	$V_{GE(th)}$	$I_C = 7\text{mA}, V_{CE} = 10V$	4.5	6.0	7.5	Volts
Collector-Emitter Saturation Voltage	$V_{CE(sat)}$	$I_C = 60\text{A}, V_{GE} = 15V, T_j = 25^\circ\text{C}$	—	3.0	3.9**	Volts
		$I_C = 60\text{A}, V_{GE} = 15V, T_j = 125^\circ\text{C}$	—	3.6	—	Volts
Total Gate Charge	Q_G	$V_{CC} = 2250V, I_C = 60\text{A}, V_{GE} = 15V$	—	450	—	nC

Dynamic Electrical Characteristics, $T_j = 25\text{ }^\circ\text{C}$ unless otherwise specified

Characteristics	Symbol	Test Conditions	Min.	Typ.	Max.	Units
Input Capacitance	C_{ies}		—	9.0	—	nF
Output Capacitance	C_{oes}	$V_{GE} = 0V, V_{CE} = 10V$	—	0.65	—	nF
Reverse Transfer Capacitance	C_{res}		—	0.2	—	nF
Resistive	Turn-on Delay Time	$V_{CC} = 2250V,$ $I_C = 60\text{A},$	—	—	2.4	μs
	Rise Time					
Switching	Turn-off Delay Time	$V_{GE1} = V_{GE2} = 15V,$ $R_G = 120\Omega$	—	—	6.0	μs
	Fall Time					
Turn-on Switching Energy	E_{on}	$T_j = 125^\circ\text{C}, I_C = 60\text{A}, V_{CC} = 2250V,$	—	250	—	mJ/P
Turn-off switching Energy	E_{off}	$V_{GE} = \pm 15V, R_G = 120\Omega, L_S = 180\text{nH}$	—	170	—	mJ/P

Thermal and Mechanical Characteristics, $T_j = 25\text{ }^\circ\text{C}$ unless otherwise specified

Characteristics	Symbol	Test Conditions	Min.	Typ.	Max.	Units
Thermal Resistance, Junction to Case	$R_{th(j-c)}$	IGBT	—	0.10	TBD	$^\circ\text{C/W}$
Thermal Resistance, Case to Sink	$R_{th(c-s)}$	$\lambda_{grease} = 1\text{W/mK}$	—	0.10	—	$^\circ\text{C/W}$
Thermal Grease Applied						

* Pulse width and repetition rate should be such that device junction temperature (T_j) does not exceed device rating.
 ** Pulse width and repetition rate should be such that device junction temperature rise is negligible.

QIS4506002
HV Single Discrete IGBT
 60 Amperes/4500 Volts

