

Powerex, Inc., 173 Pavilion Lane, Youngwood, Pennsylvania 15697 (724) 925-7272  
www.pwr.com

### POW-R-BLOK™ Dual Diode Isolated Module 250 Amperes / Up to 3400 Volts

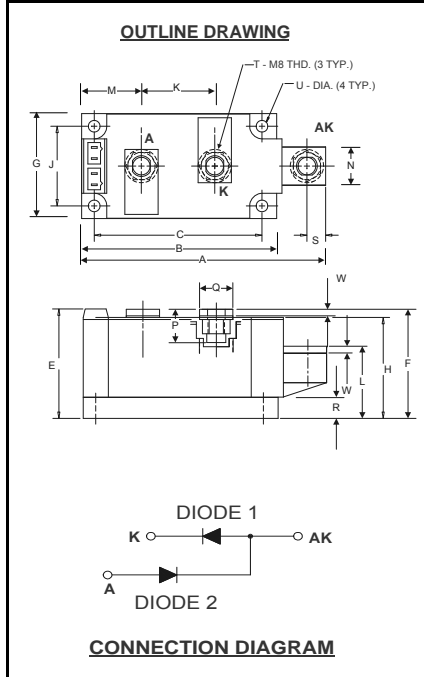

**ND413425**  
**Dual Diode Isolated**  
**POW-R-BLOK™ Module**  
250 Amperes / 2600 - 3400 Volts

#### Description:

Powerex Dual Diode Modules are designed for use in applications requiring rectification and isolated packaging. The modules are isolated for easy mounting with other components on a common heatsink. POW-R-BLOK™ has been tested and recognized by the Underwriters Laboratories.

#### Features:

- Electrically Isolated Heatsinking
- Aluminum Nitride Isolator
- Compression Bonded Elements
- Metal Baseplate
- Low Thermal Impedance for Improved Current Capability
- UL Recognized

#### Benefits:

- No Additional Insulation Components Required
- Easy Installation
- No Clamping Components Required
- Reduce Engineering Time

#### Applications:

- Bridge Circuits
- AC & DC Motor Drives
- Battery Supplies
- Power Supplies
- Large IGBT Circuit Front Ends

#### ND41 Outline Dimensions

Dimension	Inches	Millimeters
A	4.57	116
B	3.66	93
C	3.15	80.0
E	2.06	52.3
F	2.05	52.0
G	1.97	50.0
H	1.90	48.3
J	1.50	38.1
K	1.38	35.0
L	1.26	32.0
M	1.122	28.5
N	.71	18.0
P	.57	14.5
Q	.625	15.9
R	.394	10.00
S	.350	8.9
T	M8 Metric	M8
U	.250 Dia.	6.35 Dia.
W	.12	3.0

Note: Dimensions are for reference only.

#### Ordering Information:

Select the complete eight digit module part number from the table below.

Example: ND413425 is a 3400 Volt, 250 Ampere Dual Diode Isolated POW-R-BLOK™ Module

Type	Voltage Volts (x100)	Current Amperes (x10)
ND41	26 28 30 32 34	25

**Absolute Maximum Ratings**

Characteristics	Conditions	Symbol		Units
Repetitive Peak Reverse Blocking Voltage		$V_{RRM}$	up to 3400	V
Non-Repetitive Peak Reverse Blocking Voltage ( $t < 5$ msec)		$V_{RSM}$	$V_{RRM} + 100$	V
RMS Forward Current	180° Conduction, $T_c=112^\circ\text{C}$	$I_{F(RMS)}$	314	A
	<b>180° Conduction, <math>T_c=101^\circ\text{C}</math></b>	$I_{F(RMS)}$	<b>392</b>	A
	180° Conduction, $T_c=89^\circ\text{C}$	$I_{F(RMS)}$	470	A
Average Forward Current	180° Conduction, $T_c=112^\circ\text{C}$	$I_{F(AV)}$	200	A
	<b>180° Conduction, <math>T_c=101^\circ\text{C}</math></b>	$I_{F(AV)}$	<b>250</b>	A
	180° Conduction, $T_c=89^\circ\text{C}$	$I_{F(AV)}$	300	A
Peak One Cycle Surge Current, Non-Repetitive $T_j$ initial = 150C	60 Hz, 100% $V_{RRM}$ reapplied	$I_{FSM}$	5000	A
	50 Hz, 100% $V_{RRM}$ reapplied	$I_{FSM}$	4750	A
	60 Hz, 0V reapplied	$I_{FSM}$	7500	A
	50 Hz, 0V reapplied	$I_{FSM}$	7125	A
Peak Three Cycle Surge Current, Non-Repetitive $T_j$ initial = 150C	60 Hz, 100% $V_{RRM}$ reapplied	$I_{FSM}$	4015	A
	50 Hz, 100% $V_{RRM}$ reapplied	$I_{FSM}$	3815	A
	60 Hz, 0V reapplied	$I_{FSM}$	6020	A
	50 Hz, 0V reapplied	$I_{FSM}$	5720	A
Peak Ten Cycle Surge Current, Non-Repetitive $T_j$ initial = 150C	60 Hz, 100% $V_{RRM}$ reapplied	$I_{FSM}$	3155	A
	50 Hz, 100% $V_{RRM}$ reapplied	$I_{FSM}$	2995	A
	60 Hz, 0V reapplied	$I_{FSM}$	4730	A
	50 Hz, 0V reapplied	$I_{FSM}$	4495	A
$I^2t$ for Fusing for One Cycle $T_j$ initial = 150C	8.3 msec, 100% $V_{RRM}$ reapplied	$I^2t$	104,000	$\text{A}^2 \text{ sec}$
	10 msec, 100% $V_{RRM}$ reapplied	$I^2t$	113,000	$\text{A}^2 \text{ sec}$
	8.3 msec, 0V reapplied	$I^2t$	233,000	$\text{A}^2 \text{ sec}$
	10 msec, 0V reapplied	$I^2t$	254,000	$\text{A}^2 \text{ sec}$
Operating Temperature		$T_J$	-40 to +150	$^\circ\text{C}$
Storage Temperature		$T_{stg}$	-40 to +150	$^\circ\text{C}$
Max. Mounting Torque, M6 Mounting Screw			45	in.-Lb.
			5	Nm
Max. Mounting Torque, M8 Terminal Screw			110	in.-Lb.
			12	Nm
Module Weight, Typical			840	g
			1.85	lb.
V Isolation @ 25C, 60Hz 1 sec		$V_{rms}$	3600	V
V Isolation @ 25C, 60Hz 60 sec		$V_{rms}$	3000	V

Information presented is based upon manufacturers testing and projected capabilities.  
 This information is subject to change without notice.  
 The manufacturer makes no claim as to the suitability of use, reliability, capability,  
 or future availability of this product.

**Electrical Characteristics, T<sub>J</sub>=25°C unless otherwise specified**

Characteristics	Symbol	Test Conditions	Min.	Max.	Units
Repetitive Peak Reverse Leakage Current	I <sub>RRM</sub>	Up to 3400V, T <sub>J</sub> =150°C		50	mA
Peak On-State Voltage	V <sub>FM</sub>	I <sub>FM</sub> =1500A		1.80	V
Threshold Voltage, Low-level	V <sub>(TO)1</sub>	T <sub>J</sub> = 150°C, I = 15%I <sub>F(AV)</sub> to πI <sub>F(AV)</sub>		1.095	V
Slope Resistance, Low-level	r <sub>T1</sub>			0.482	mΩ
Threshold Voltage, High-level	V <sub>(TO)2</sub>	T <sub>J</sub> = 150°C, I = πI <sub>F(AV)</sub> to I <sub>FSM</sub>		1.109	V
Slope Resistance, High-level	r <sub>T2</sub>			0.471	mΩ
V <sub>TM</sub> Coefficients, Full Range		T <sub>J</sub> = 150°C, I = 15%I <sub>F(AV)</sub> to I <sub>FSM</sub> V <sub>FM</sub> = A+ B Ln I + C I + D Sqrt I	A = B = C = D =	1.1227 -1.08 E-2 4.53 E-4 2.42 E-2	
Diode Reverse Recovery Time (Typical)	t <sub>rr</sub>	I <sub>fm</sub> = 1500A, T <sub>p</sub> = 190 μs di/dt = -25A/μs		20	μs

**Thermal Characteristics**

Characteristics	Symbol		Max.	Units
Thermal Resistance, Junction to Case	R <sub>ΘJ-C</sub>	Per Module, both conducting Per Junction both conducting	0.07 0.14	°C/W °C/W
Thermal Impedance Coefficients	Z <sub>ΘJ-C</sub>	Z <sub>ΘJ-C</sub> = K <sub>1</sub> (1-exp(-t/τ <sub>1</sub> )) + K <sub>2</sub> (1-exp(-t/τ <sub>2</sub> )) + K <sub>3</sub> (1-exp(-t/τ <sub>3</sub> )) + K <sub>4</sub> (1-exp(-t/τ <sub>4</sub> ))	K <sub>1</sub> = 5.27E-3 K <sub>2</sub> = 1.17E-2 K <sub>3</sub> = 5.26E-2 K <sub>4</sub> = 6.97E-2	τ <sub>1</sub> = 1.69E-4 τ <sub>2</sub> = 2.07E-2 τ <sub>3</sub> = 2.37E-1 τ <sub>4</sub> = 2.46
Thermal Resistance, Case to Sink Lubricated	R <sub>ΘC-S</sub>	Per Module	0.03	°C/W

Powerex, Inc., 173 Pavilion Lane, Youngwood, Pennsylvania 15697 (724) 925-7272  
www.pwr.com

## POW-R-BLOK™ Dual Diode Isolated Module 250 Amperes / Up to 3400 Volts

