

Powerex, Inc., 173 Pavilion Lane, Youngwood, Pennsylvania 15697 (724) 925-7272
www.pwr.com

POW-R-BLOK™
Single SCR Isolated Module
430 Amperes / 1800-2200 Volts

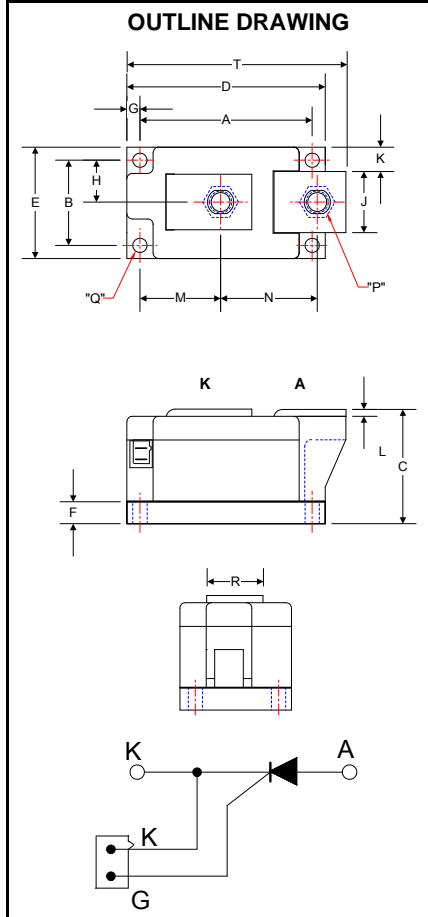

LS43_43
Single SCR
POW-R-BLOK™ Module
430 Amperes / 1800-2200 Volts

LS43 Outline Dimensions

Dimension	Inches	Millimeters
A	3.15	80.0
B	1.50	38.0
C	2.05	52.1
D	3.62	92.0
E	1.97	50.0
F	0.39	9.9
G	0.24	6.1
H	0.75	19.0
J	0.99	25.1
K	0.48	12.2
L	0.12	3.1
M	1.45	36.8
N	1.76	44.7
P	M10 Metric	M10
Q	0.250 Dia.	6.35 Dia.
R	0.99	25.1
S	0.110 x .032	2.5 x 0.8
T	3.99	101.3

Note: Dimensions are for reference only.

Ordering Information:

Select the complete eight-digit module part number from the table below.

Example: LS432243 is a 2200 Volt, 430 Ampere Single SCR Isolated POW-R-BLOK™ Module

Type	Voltage Volts (x100)	Current Amperes (x10)
LS43	18	43
	20	
	22	

Description:

Powerex Single SCR Modules are designed for use in applications requiring rectification and isolated packaging. The modules are isolated for easy mounting with other components on a common heatsink. POW-R-BLOK™ has been tested and recognized by the Underwriters Laboratories.

Features:

- Electrically Isolated Heatsinking
- Aluminum Nitride Insulator
- Compression Bonded Elements
- Metal Baseplate
- Low Thermal Impedance for Improved Current Capability
- Quick Connect Gate Terminal with Provision for Keyed Mating Plug
- UL Recognized

Benefits:

- No Additional Insulation Components Required
- Easy Installation
- No Clamping Components Required
- Reduce Engineering Time

Applications:

- Bridge Circuits
- AC & DC Motor Drives
- Battery Supplies
- Power Supplies
- Large IGBT Circuit Front Ends

Absolute Maximum Ratings

Characteristics	Conditions	Symbol	Units	
Repetitive Peak Forward and Reverse Blocking Voltage		V_{DRM} & V_{RRM}	up to 2200	V
Non-Repetitive Peak Blocking Voltage ($t < 5$ msec)		V_{RSM}	$V_{RRM} + 100$	V
RMS Forward Current	180° Conduction, $T_C=70^\circ\text{C}$	$I_{T(RMS)}$	800	A
Average Forward Current	180° Conduction, $T_C=80^\circ\text{C}$	$I_{T(AV)}$	430	A
	180° Conduction, $T_C=70^\circ\text{C}$	$I_{T(AV)}$	510	A
Peak One Cycle Surge Current, Non-Repetitive	60 Hz, 100% V_{RRM} reapplied, $T_j=25^\circ\text{C}$	I_{TSM}	14,000	A
	60 Hz, No V_{RRM} reapplied, $T_j=25^\circ\text{C}$	I_{TSM}	16,000	A
	60 Hz, 100% V_{RRM} reapplied, $T_j=125^\circ\text{C}$	I_{TSM}	12,000	A
	60 Hz, No V_{RRM} reapplied, $T_j=125^\circ\text{C}$	I_{TSM}	14,000	A
	50 Hz, 100% V_{RRM} reapplied, $T_j=25^\circ\text{C}$	I_{TSM}	12,000	A
	50 Hz, No V_{RRM} reapplied, $T_j=25^\circ\text{C}$	I_{TSM}	14,000	A
	50 Hz, 100% V_{RRM} reapplied, $T_j=125^\circ\text{C}$	I_{TSM}	10,000	A
	50 Hz, No V_{RRM} reapplied, $T_j=125^\circ\text{C}$	I_{TSM}	12,000	A
Peak Three Cycle Surge Current, Non-Repetitive	60 Hz, 100% V_{RRM} reapplied	I_{TSM}	8,600	A
Peak Ten Cycle Surge Current, Non-Repetitive	60 Hz, 100% V_{RRM} reapplied	I_{TSM}	7,500	A
I^2t for Fusing for One Cycle	8.3 milliseconds, $T_j=25^\circ\text{C}$	I^2t	1.07×10^6	$\text{A}^2 \text{sec}$
	8.3 milliseconds, $T_j=125^\circ\text{C}$	I^2t	0.82×10^6	$\text{A}^2 \text{sec}$
	10 milliseconds, $T_j=25^\circ\text{C}$	I^2t	0.98×10^6	$\text{A}^2 \text{sec}$
	10 milliseconds, $T_j=125^\circ\text{C}$	I^2t	0.72×10^6	$\text{A}^2 \text{sec}$
Maximum Rate-of-Rise of On-State Current, (Repetitive)	Per JEDEC Standard 397 5.2.2.6	di/dt	200	$\text{A}/\mu\text{s}$
Operating Temperature		T_J	-40 to +130	$^\circ\text{C}$
Storage Temperature		T_{stg}	-40 to +150	$^\circ\text{C}$
Max. Mounting Torque, M6 Mounting Screw			55	in. – Lb.
			6	Nm
Max. Mounting Torque, M10 Terminal Screw			110	in. – Lb.
			12	Nm
Module Weight, Typical			816	g
			1.80	lb
V Isolation @ 25C		V_{rms}	3000	V

Information presented is based upon manufacturers testing and projected capabilities. This information is subject to change without notice. The manufacturer makes no claim as to the suitability of use, reliability, capability, or future availability of this product.

Electrical Characteristics, T_J=25°C unless otherwise specified

Characteristics	Symbol	Test Conditions	Min.	Max.	Units
Repetitive Peak Forward Leakage Current	I _{DRM}	Up to 2200V, T _J =125°C		80	mA
Repetitive Peak Reverse Leakage Current	I _{RPM}	Up to 2200V, T _J =125°C		80	mA
Peak On-State Voltage	V _{FM}	I _{TM} =1500A		1.77	V
Threshold Voltage, Low-level	V _{(TO)1}	T _J = 130°C, I = 15%I _{T(AV)} to πI _{T(AV)}		0.88	V
Slope Resistance, Low-level	r _{T1}			0.66	mΩ
Threshold Voltage, High-level	V _{(TO)2}	T _J = 130°C, I = πI _{T(AV)} to I _{TSM}		1.34	V
Slope Resistance, High-level	r _{T2}			0.32	mΩ
V _{TM} Coefficients, Full Range		T _J = 130°C, I = 10A to 6kA V _{TM} = A + B Ln I + C I + D Sqrt I	A = B = C = D =	0.766 -1.046 E-02 1.805 E-05 2.00 E-02	
Minimum dV/dt	dV/dt	Exponential to V _{DRM} T _J =130°C, Gate Open	1000 Typ.		V/μs
Gate Trigger Current	I _{GT}	T _J =25°C, V _D =12V		200	mA
Gate Trigger Voltage	V _{GT}	T _J =25°C, V _D =12V		3.0	Volts
Non-Triggering Gate Voltage	V _{GDM}	T _J =130°C, V _D = ½ V _{DRM}		0.25	Volts
Peak Forward Gate Current	I _{GTM}			4.0	Amp
Peak Reverse Gate Voltage	V _{GRM}			5	Volts

Thermal Characteristics

Characteristics	Symbol		Max.	Units
Thermal Resistance, Junction to Case	R _{ΘJ-C}	Per Module/Junction	0.0650	°C/W
Thermal Impedance Coefficients	Z _{ΘJ-C}	Z _{ΘJ-C} = K ₁ (1-exp(-t/τ ₁)) + K ₂ (1-exp(-t/τ ₂)) + K ₃ (1-exp(-t/τ ₃)) + K ₄ (1-exp(-t/τ ₄))	K ₁ = 8.03E-04 K ₂ = 1.03E-02 K ₃ = 1.64E-02 K ₄ = 3.75E-02	τ ₁ = 3.39E-04 τ ₂ = 3.15E-03 τ ₃ = 0.106 τ ₄ = 2.066
Thermal Resistance, Case to Sink Lubricated	R _{ΘC-S}	Per Module	0.02	°C/W

Maximum On-State Forward Voltage Drop
($T_j = 125\text{ }^\circ\text{C}$)

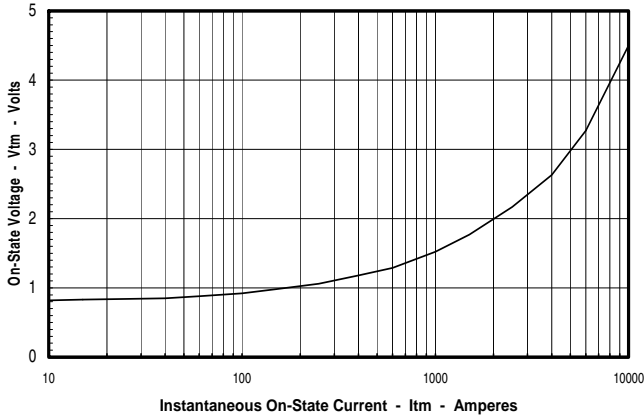

Maximum Transient Thermal Impedance
(Junction to Case)

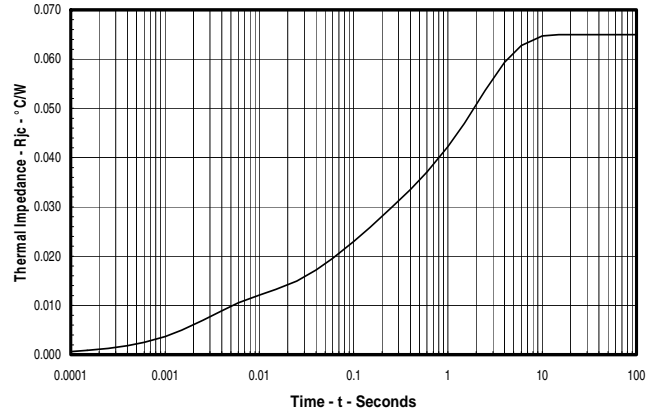

Maximum On-State Power Dissipation
(Sinusoidal Waveform)

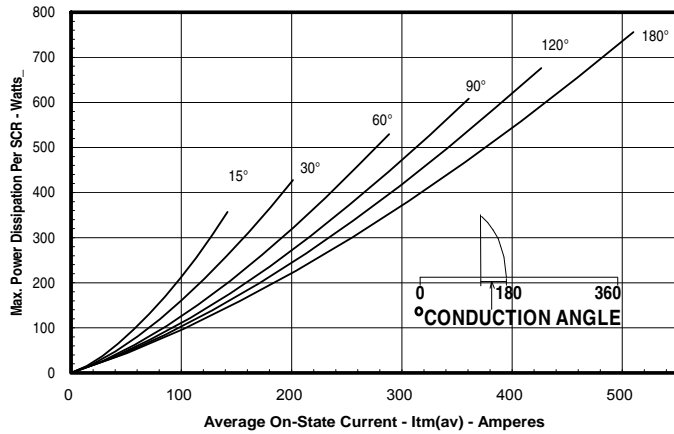

Maximum Allowable Case Temperature
(Sinusoidal Waveform)

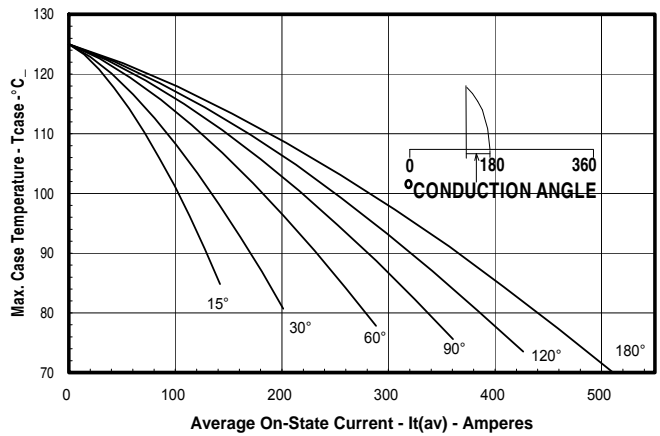

Maximum On-State Power Dissipation
(Rectangular Waveform)

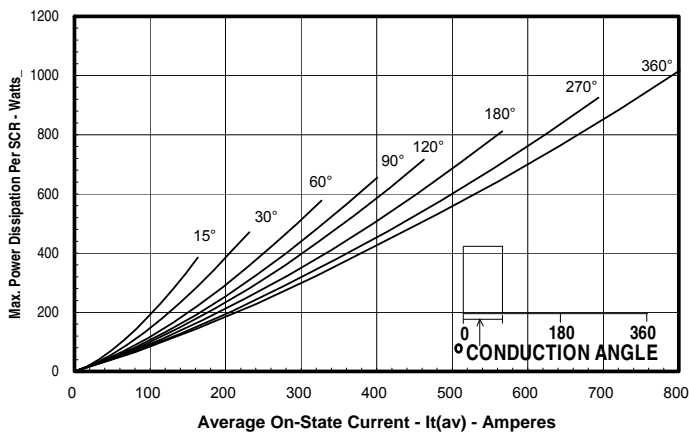

Maximum Allowable Case Temperature
(Rectangular Waveform)

