

Single IGBTMOD™ HVIGBT 600 Amperes/4500 Volts

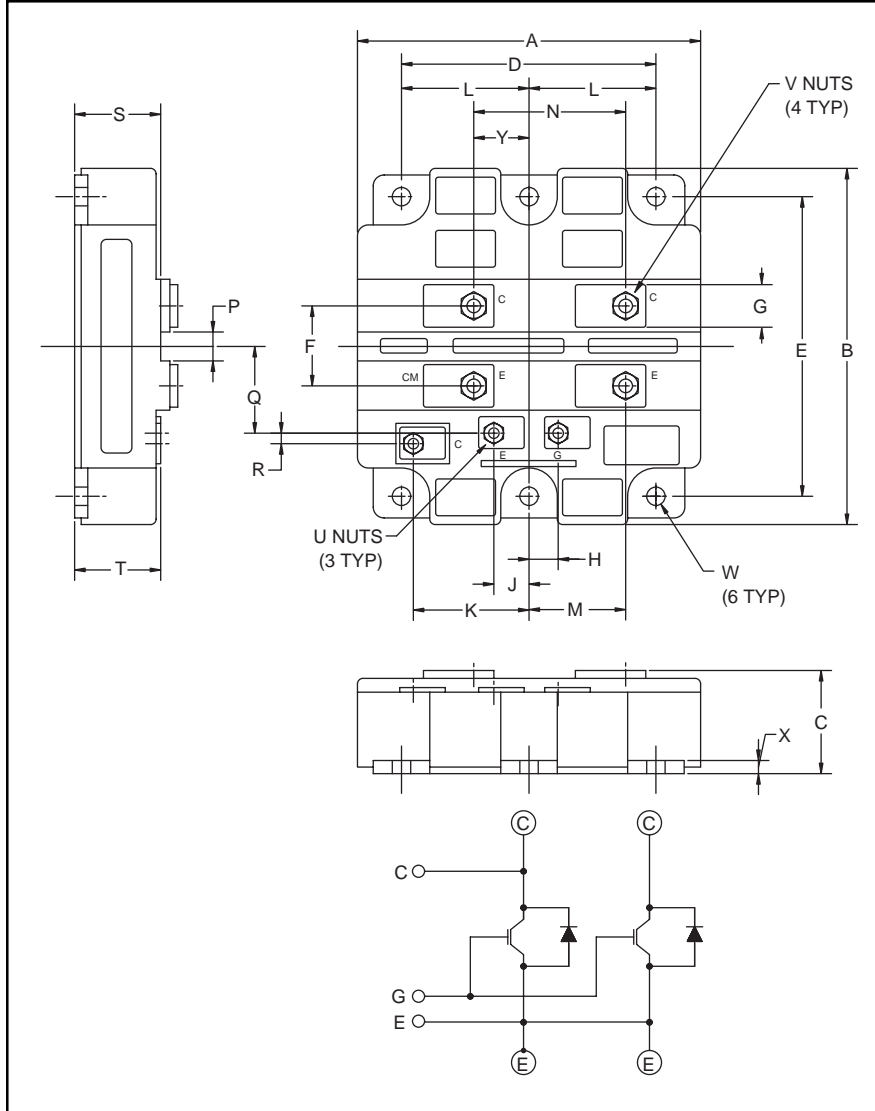

Outline Drawing and Circuit Diagram

Dimensions	Inches	Millimeters
A	5.12	130.0
B	5.51	140.0
C	1.50	38.0
D	4.48	114.0
E	4.88±0.01	124.0±0.25
F	1.57	40.0
G	0.79	20.0
H	0.41	10.35
J	0.42	10.65
K	1.92	48.8
L	2.24±0.01	57.0±0.25
M	1.71	43.5

Dimensions	Inches	Millimeters
N	2.42	61.5
P	0.59	15.0
Q	1.57	40.0
R	0.20	5.2
S	1.16	29.5
T	1.10	28.0
U	M4 Metric	M4
V	M8 Metric	M8
W	0.28 Dia.	Dia. 7.0
X	0.20	5.0
Y	0.71	18.0

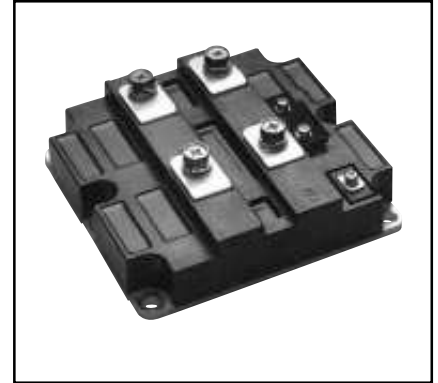

Description:

Powerex IGBTMOD™ Modules are designed for use in switching applications. Each module consists of one IGBT Transistor with a reverse-connected super-fast recovery free-wheel diode. All components and interconnects are isolated from the heat sinking baseplate, offering simplified system assembly and thermal management.

Features:

- Low Drive Power
- Low $V_{CE(sat)}$
- Super-Fast Recovery Free-Wheel Diode
- Isolated Baseplate for Easy Heat Sinking

Applications:

- Traction
- Medium Voltage Drives
- High Voltage Power Supplies

Ordering Information:

Example: Select the complete part module number you desire from the table below -i.e. CM600HB-90H is a 4500V (V_{CES}), 600 Ampere Single IGBTMOD™ Power Module.

Type	Current Rating Amperes	V_{CES} Volts (x 50)
CM	600	90



Powerex, Inc., 200 Hillis Street, Youngwood, Pennsylvania 15697-1800 (724) 925-7272

CM600HB-90H
Single IGBTMOD™ HVIGBT
 600 Amperes/4500 Volts

Absolute Maximum Ratings, $T_j = 25\text{ }^\circ\text{C}$ unless otherwise specified

Ratings	Symbol	CM600HB-90H	Units
Junction Temperature	T_j	-40 to 150	$^\circ\text{C}$
Storage Temperature	T_{stg}	-40 to 125	$^\circ\text{C}$
Collector-Emitter Voltage ($V_{GE} = 0V$)	V_{CES}	4500	Volts
Gate-Emitter Voltage ($V_{CE} = 0V$)	V_{GES}	± 20	Volts
Collector Current ($T_c = 25^\circ\text{C}$)	I_C	600	Amperes
Peak Collector Current (Pulse)	I_{CM}	1200*	Amperes
Diode Forward Current** ($T_c = 25^\circ\text{C}$)	I_E	600	Amperes
Diode Forward Surge Current** (Pulse)	I_{EM}	1200*	Amperes
Maximum Collector Dissipation ($T_c = 25^\circ\text{C}$, IGBT Part, $T_j \leq 125^\circ\text{C}$)	P_C	6700	Watts
Max. Mounting Torque M8 Terminal Screws	–	115	in-lb
Max. Mounting Torque M6 Mounting Screws	–	53	in-lb
Max. Mounting Torque M4 Auxiliary Terminal Screws	–	17	in-lb
Module Weight (Typical)	–	1.5	kg
Isolation Voltage (Charged Part to Baseplate, AC 60Hz 1 min.)	V_{iso}	6000	Volts

* Pulse width and repetition rate should be such that device junction temperature (T_j) does not exceed $T_{j(max)}$ rating.
 **Represents characteristics of the anti-parallel, emitter-to-collector free-wheel diode (FWDi).

Static Electrical Characteristics, $T_j = 25\text{ }^\circ\text{C}$ unless otherwise specified

Characteristics	Symbol	Test Conditions	Min.	Typ.	Max.	Units
Collector-Cutoff Current	I_{CES}	$V_{CE} = V_{CES}, V_{GE} = 0V$	–	–	12.0	mA
Gate Leakage Current	I_{GES}	$V_{GE} = V_{GES}, V_{CE} = 0V$	–	–	0.5	μA
Gate-Emitter Threshold Voltage	$V_{GE(th)}$	$I_C = 60\text{mA}, V_{CE} = 10V$	4.5	6.0	7.5	Volts
Collector-Emitter Saturation Voltage	$V_{CE(sat)}$	$I_C = 600\text{A}, V_{GE} = 15V, T_j = 25^\circ\text{C}$	–	3.0	3.9*	Volts
		$I_C = 600\text{A}, V_{GE} = 15V, T_j = 125^\circ\text{C}$	–	3.3	–	Volts
Total Gate Charge	Q_G	$V_{CC} = 2250V, I_C = 600\text{A}, V_{GE} = 15V$	–	5.4	–	μC
Emitter-Collector Voltage**	V_{EC}	$I_E = 600\text{A}, V_{GE} = 0V$	–	4.0	5.2	Volts

* Pulse width and repetition rate should be such that device junction temperature rise is negligible.
 **Represents characteristics of the anti-parallel, emitter-to-collector free-wheel diode (FWDi).



Powerex, Inc., 200 Hillis Street, Youngwood, Pennsylvania 15697-1800 (724) 925-7272

CM600HB-90H
Single IGBTMOD™ HVIGBT
 600 Amperes/4500 Volts

Dynamic Electrical Characteristics, $T_j = 25\text{ }^\circ\text{C}$ unless otherwise specified

Characteristics	Symbol	Test Conditions	Min.	Typ.	Max.	Units
Input Capacitance	C_{ies}		–	108	–	nF
Output Capacitance	C_{oes}	$V_{GE} = 0V, V_{CE} = 10V$	–	8.0	–	nF
Reverse Transfer Capacitance	C_{res}		–	2.4	–	nF
Resistive	Turn-on Delay Time	$V_{CC} = 2250V, I_C = 600A,$ $V_{GE1} = V_{GE2} = 15V,$ $R_G = 15\Omega$	–	–	2.4	μs
Load	Rise Time		$t_{d(on)}$			
Switching	Turn-off Delay Time	Resistive Load Switching Operation	–	–	6.0	μs
Times	Fall Time		$t_{d(off)}$			
Diode Reverse Recovery Time**	t_{rr}	$I_E = 600A, di_E/dt = -1200A/\mu s$	–	–	1.8	μs
Diode Reverse Recovery Charge**	Q_{rr}	$I_E = 600A, di_E/dt = -1200A/\mu s$	–	240*	–	μC

* Pulse width and repetition rate should be such that device junction temperature rise is negligible.

**Represents characteristics of the anti-parallel, emitter-to-collector free-wheel diode (FWDi).

Thermal and Mechanical Characteristics, $T_j = 25\text{ }^\circ\text{C}$ unless otherwise specified

Characteristics	Symbol	Test Conditions	Min.	Typ.	Max.	Units
Thermal Resistance, Junction to Case	$R_{th(j-c)}$	Per IGBT	–	–	0.015	K/W
Thermal Resistance, Junction to Case	$R_{th(j-c)}$	Per FWDi	–	–	0.030	K/W
Contact Thermal Resistance, Case to Fin	$R_{th(c-f)}$	Per Module, Thermal Grease Applied	–	0.010	–	K/W



Powerex, Inc., 200 Hillis Street, Youngwood, Pennsylvania 15697-1800 (724) 925-7272

CM600HB-90H
Single IGBTMOD™ HVIGBT
 600 Amperes/4500 Volts

