

# CM400E2G-130H

HIGH POWER SWITCHING USE  
INSULATED TYPE

Prepared by	K.Kurachi	Revision: B
Date	I.Umezaki	24-Feb.-2009

3<sup>th</sup>-Version HVIGBT (High Voltage Insulated Gate Bipolar Transistor) Modules

## CM400E2G-130H

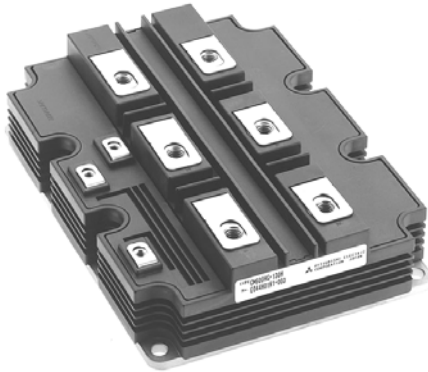

- $I_C$  ..... 400 A
- $V_{CES}$  ..... 6500 V
- 1-element in a Pack (for brake chopper)
- Insulated Type
- AISiC Baseplate

## APPLICATION

Traction drives, High Reliability Converters / Inverters, DC choppers

## OUTLINE DRAWING & CIRCUIT DIAGRAM

Dimensions in mm

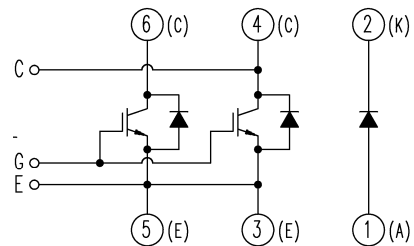
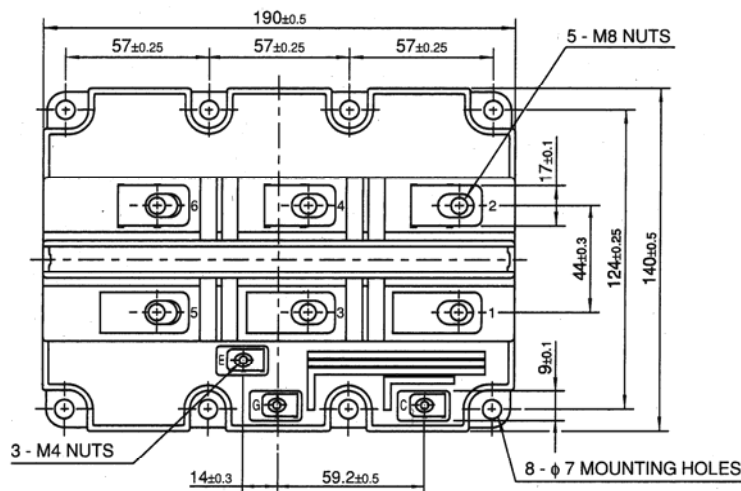

接続図  
CIRCUIT DIAGRAM

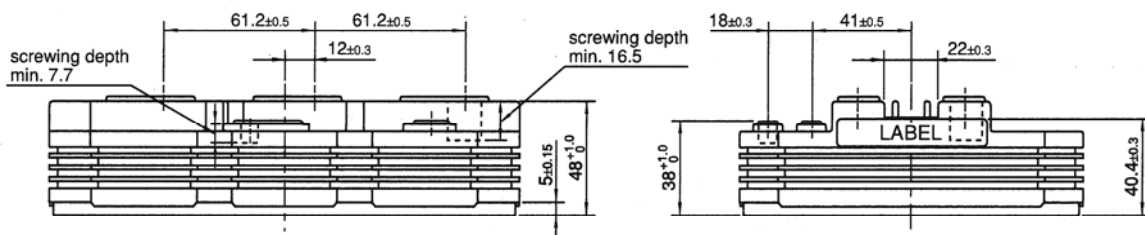

HVIGBT (High Voltage Insulated Gate Bipolar Transistor) MODULES

# CM400E2G-130H

HIGH POWER SWITCHING USE  
INSULATED TYPE

3<sup>rd</sup>-Version HVIGBT (High Voltage Insulated Gate Bipolar Transistor) Modules

## MAXIMUM RATINGS

Symbol	Item	Conditions	Ratings		Unit
$V_{CES}$	Collector-emitter voltage	$V_{GE} = 0\text{ V}$	$T_j = -40\text{ }^\circ\text{C}$	5800	V
			$T_j = +25\text{ }^\circ\text{C}$	6300	
			$T_j = +125\text{ }^\circ\text{C}$	6500	
$V_{GES}$	Gate-emitter voltage	$V_{CE} = 0\text{ V}, T_j = 25\text{ }^\circ\text{C}$		$\pm 20$	V
$I_C$	Collector current	DC, $T_c = 80\text{ }^\circ\text{C}$		400	A
$I_{CM}$		Pulse (Note 1)		800	A
$I_E$	Emitter current (Note 2)	DC		400	A
$I_{EM}$		Pulse (Note 1)		800	A
$P_c$	Maximum power dissipation (Note 3)	$T_c = 25\text{ }^\circ\text{C}$ , IGBT part		5900	W
$V_{iso}$	Isolation voltage	RMS, sinusoidal, $f = 60\text{ Hz}$ , $t = 1\text{ min.}$		10200	V
$V_e$	Partial discharge extinction voltage	RMS, sinusoidal, $f = 60\text{ Hz}$ , $Q_{PD} \leq 10\text{ pC}$		5100	V
$T_j$	Junction temperature			$-40 \sim +150$	$^\circ\text{C}$
$T_{op}$	Operating temperature			$-40 \sim +125$	$^\circ\text{C}$
$T_{stg}$	Storage temperature			$-40 \sim +125$	$^\circ\text{C}$
$t_{psc}$	Maximum short circuit pulse width	$V_{CC} = 4500\text{ V}, V_{CE} \leq V_{CES}, V_{GE} = 15\text{ V}, T_j = 125\text{ }^\circ\text{C}$		10	$\mu\text{s}$

## ELECTRICAL CHARACTERISTICS

Symbol	Item	Conditions	Limits			Unit	
			Min	Typ	Max		
$I_{CES}$	Collector cutoff current	$V_{CE} = V_{CES}, V_{GE} = 0\text{ V}$	$T_j = 25\text{ }^\circ\text{C}$	—	—	7	mA
			$T_j = 125\text{ }^\circ\text{C}$	—	20	60	
$V_{GE(th)}$	Gate-emitter threshold voltage	$V_{CE} = 10\text{ V}, I_C = 40\text{ mA}, T_j = 25\text{ }^\circ\text{C}$	5.0	6.0	7.0	V	
$I_{GES}$	Gate leakage current	$V_{GE} = V_{GES}, V_{CE} = 0\text{ V}, T_j = 25\text{ }^\circ\text{C}$	-0.5	—	0.5	$\mu\text{A}$	
$C_{ies}$	Input capacitance	$V_{CE} = 10\text{ V}, V_{GE} = 0\text{ V}, f = 100\text{ kHz}$ $T_j = 25\text{ }^\circ\text{C}$	—	82.0	—	nF	
$C_{oes}$	Output capacitance		—	5.0	—	nF	
$C_{res}$	Reverse transfer capacitance		—	1.4	—	nF	
$Q_g$	Total gate charge	$V_{CC} = 3600\text{ V}, I_C = 400\text{ A}$ $V_{GE} = \pm 15\text{ V}, T_j = 25\text{ }^\circ\text{C}$	—	6.6	—	$\mu\text{C}$	
$V_{CE(sat)}$	Collector-emitter saturation voltage	$I_C = 400\text{ A}$ (Note 4) $V_{GE} = 15\text{ V}$	$T_j = 25\text{ }^\circ\text{C}$	—	4.5	—	V
			$T_j = 125\text{ }^\circ\text{C}$	—	4.6	—	
$t_{d(on)}$	Turn-on delay time	$V_{CC} = 3600\text{ V}, I_C = 400\text{ A}$ $V_{GE} = \pm 15\text{ V}, R_{G(on)} = 15\text{ }^\Omega$ $T_j = 125\text{ }^\circ\text{C}, L_s = 170\text{ nH}$	—	1.2	—	$\mu\text{s}$	
$t_r$	Turn-on rise time		—	0.35	—	$\mu\text{s}$	
$E_{on(10\%)}$	Turn-on switching energy (Note 5)		$t_{(IGBT\_off)} = 60\text{ }^\mu\text{s}$ (Note 6), Inductive load	—	3.0	—	J/P
$t_{d(off)}$	Turn-off delay time	$V_{CC} = 3600\text{ V}, I_C = 400\text{ A}$ $V_{GE} = \pm 15\text{ V}, R_{G(off)} = 50\text{ }^\Omega$ $T_j = 125\text{ }^\circ\text{C}, L_s = 170\text{ nH}$	—	8.2	—	$\mu\text{s}$	
$t_f$	Turn-off fall time		—	0.5	—	$\mu\text{s}$	
$t_{f2}$	Turn-off fall time		—	3.1	—	$\mu\text{s}$	
$E_{off(10\%)}$	Turn-off switching energy (Note 5)		Inductive load	—	2.7	—	J/P
$V_{EC}$	Emitter-collector voltage (Note 2)	$I_E = 400\text{ A}$ (Note 4) $V_{GE} = 0\text{ V}$	$T_j = 25\text{ }^\circ\text{C}$	—	4.0	—	V
			$T_j = 125\text{ }^\circ\text{C}$	—	3.6	—	
$t_{rr}$	Reverse recovery time (Note 2)	$V_{CC} = 3600\text{ V}, I_E = 400\text{ A}$ $V_{GE} = \pm 15\text{ V}, R_{G(on)} = 15\text{ }^\Omega$ $T_j = 125\text{ }^\circ\text{C}, L_s = 170\text{ nH}$	—	1.0	—	$\mu\text{s}$	
$t_{rr2}$	Reverse recovery time (Note 2)		—	2.4	—	$\mu\text{s}$	
$Q_{rr}$	Reverse recovery charge (Note 2)		—	740	—	$\mu\text{C}$	
$E_{rec(10\%)}$	Reverse recovery energy (Note 2), (Note 5)		$t_{(IGBT\_off)} = 60\text{ }^\mu\text{s}$ (Note 6), Inductive load	—	1.4	—	J/P

HVIGBT (High Voltage Insulated Gate Bipolar Transistor) MODULES



# CM400E2G-130H

HIGH POWER SWITCHING USE  
INSULATED TYPE

3<sup>rd</sup>-Version HVIGBT (High Voltage Insulated Gate Bipolar Transistor) Modules

## THERMAL CHARACTERISTICS

Symbol	Item	Conditions	Limits			Unit
			Min	Typ	Max	
$R_{th(j-c)Q}$	Thermal resistance	Junction to Case, IGBT part	—	—	21.0	K/kW
$R_{th(j-c)R}$	Thermal resistance	Junction to Case, FWDi part	—	—	33.0	K/kW
		Junction to Case, Clamp-Di part	—	—	33.0	K/kW
$R_{th(c-f)}$	Contact thermal resistance	Case to Fin, $\lambda_{grease} = 1W/m\cdot K$ , $D_{(c-f)} = 100 \mu m$	—	9.0	—	K/kW

## MECHANICAL CHARACTERISTICS

Symbol	Item	Conditions	Limits			Unit
			Min	Typ	Max	
$M_t$	Mounting torque	M8: Main terminals screw	7.0	—	15.0	N·m
$M_s$		M6: Mounting screw	3.0	—	6.0	N·m
$M_l$		M4: Auxiliary terminals screw	1.0	—	3.0	N·m
m	Mass		—	1.35	—	kg
CTI	Comparative tracking index		600	—	—	—
$d_a$	Clearance		26.0	—	—	mm
$d_s$	Creepage distance		56.0	—	—	mm
$L_{PCE}$	Parasitic stray inductance	Collector to Emitter	—	27.0	—	nH
		Anode to Cathode	—	54.0	—	nH
$R_{CC+EE}$	Internal lead resistance	$T_c = 25^\circ C$ , Collector to Emitter	—	0.19	—	m $\Omega$
		$T_c = 25^\circ C$ , Anode to Cathode	—	0.38	—	m $\Omega$

- Note 1. Pulse width and repetition rate should be such that junction temperature ( $T_j$ ) does not exceed  $T_{opmax}$  rating (125°C).
- Note 2. The symbols represent characteristics of the anti-parallel, emitter to collector free-wheel diode (FWDi) and the brake chopper, anode to cathode clamp diode (Clamp-Di).
- Note 3. Junction temperature ( $T_j$ ) should not exceed  $T_{jmax}$  rating (150°C).
- Note 4. Pulse width and repetition rate should be such as to cause negligible temperature rise.
- Note 5.  $E_{on(10\%)} / E_{off(10\%)} / E_{rec(10\%)}$  are the integral of  $0.1V_{CE} \times 0.1I_C \times dt$ .
- Note 6.  $t_{(IGBT\_off)}$  definition is shown as follows.

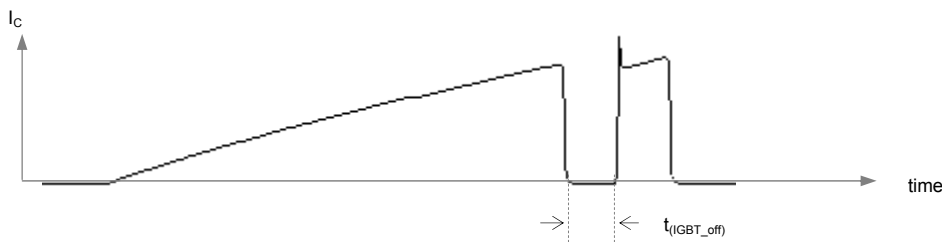

MITSUBISHI HVIGBT MODULES  
**CM400E2G-130H**

HIGH POWER SWITCHING USE  
 INSULATED TYPE

3<sup>rd</sup>-Version HVIGBT (High Voltage Insulated Gate Bipolar Transistor) Modules

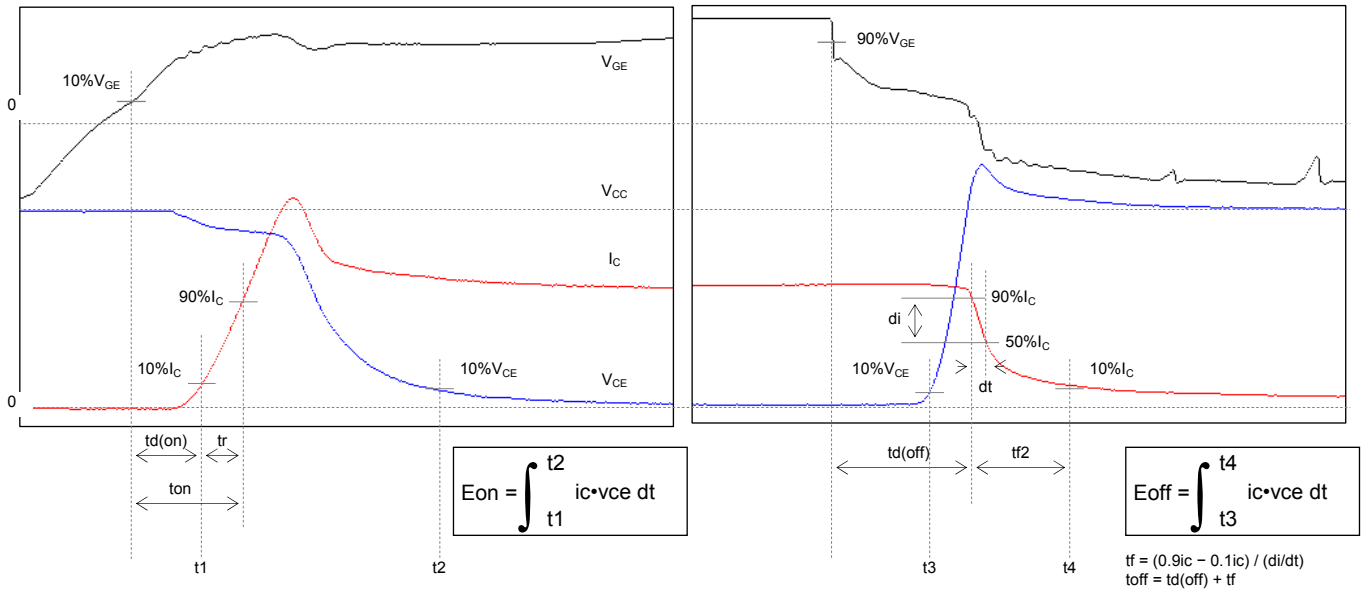

Fig. 2 – Definitions of switching times & energies of IGBT part

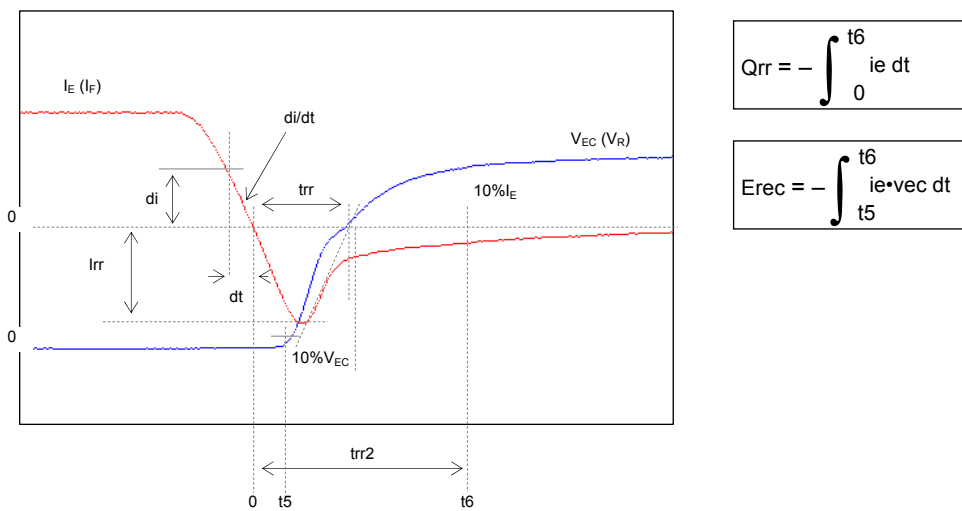

Fig. 3 – Definitions of reverse recovery charge & energy of FWDi part

# CM400E2G-130H

HIGH POWER SWITCHING USE  
INSULATED TYPE

3<sup>rd</sup>-Version HVIGBT (High Voltage Insulated Gate Bipolar Transistor) Modules

## PERFORMANCE CURVES

**OUTPUT CHARACTERISTICS (TYPICAL)**

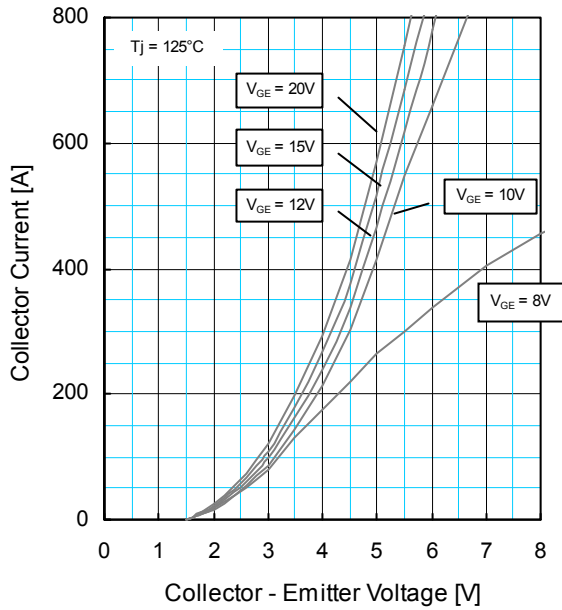

**TRANSFER CHARACTERISTICS (TYPICAL)**

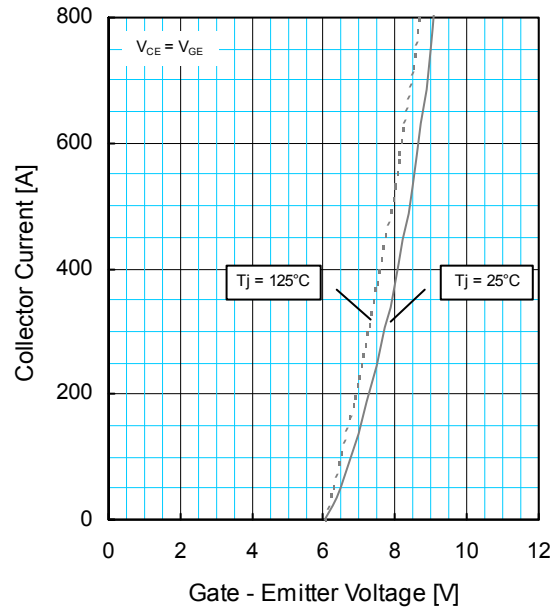

**COLLECTOR-EMITTER SATURATION VOLTAGE CHARACTERISTICS (TYPICAL)**

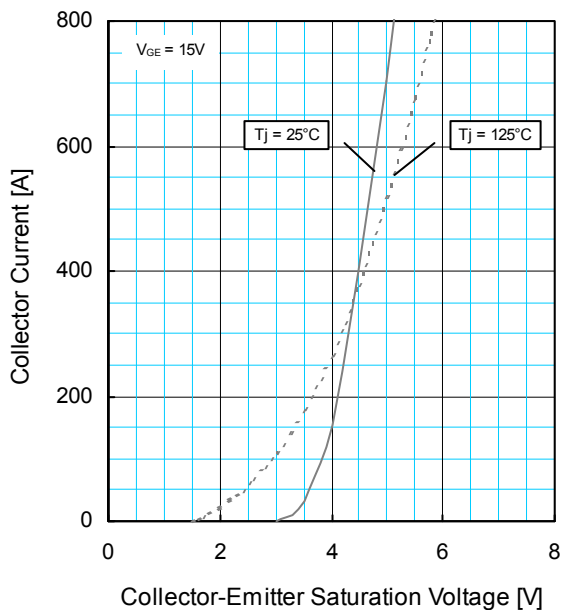

**FREE-WHEEL DIODE FORWARD CHARACTERISTICS (TYPICAL)**

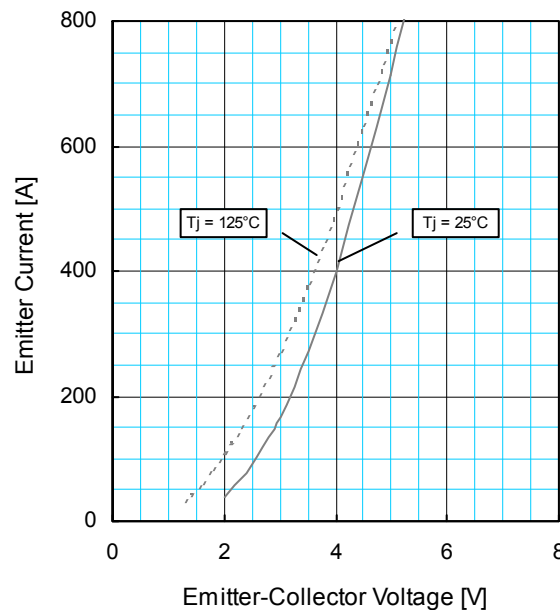

# CM400E2G-130H

HIGH POWER SWITCHING USE  
INSULATED TYPE

3<sup>rd</sup>-Version HVIGBT (High Voltage Insulated Gate Bipolar Transistor) Modules

## PERFORMANCE CURVES

**CAPACITANCE CHARACTERISTICS (TYPICAL)**

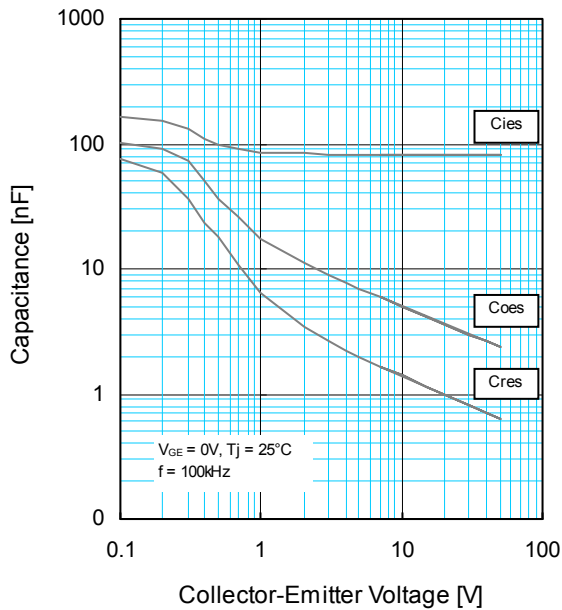

**GATE CHARGE CHARACTERISTICS (TYPICAL)**

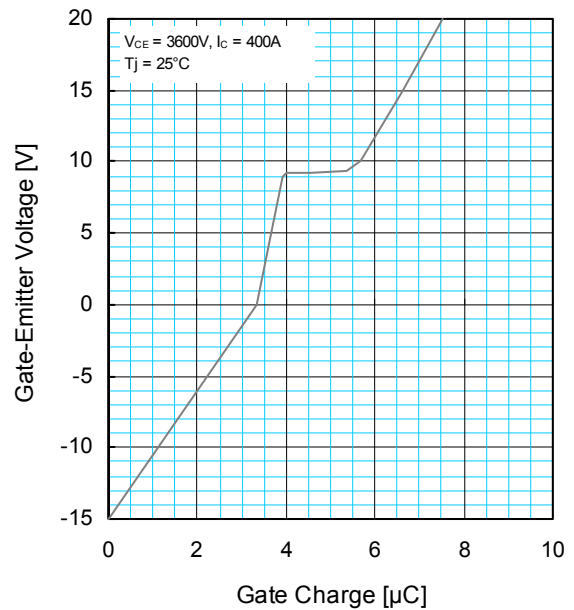

**HALF-BRIDGE SWITCHING ENERGY CHARACTERISTICS (TYPICAL)**

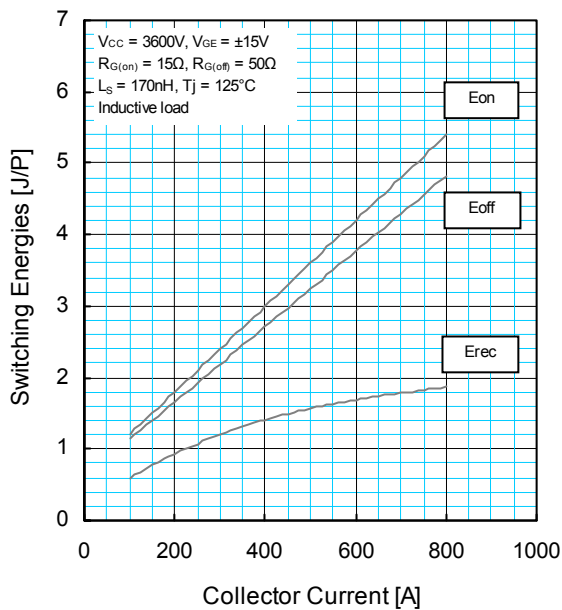

**HALF-BRIDGE SWITCHING ENERGY CHARACTERISTICS (TYPICAL)**

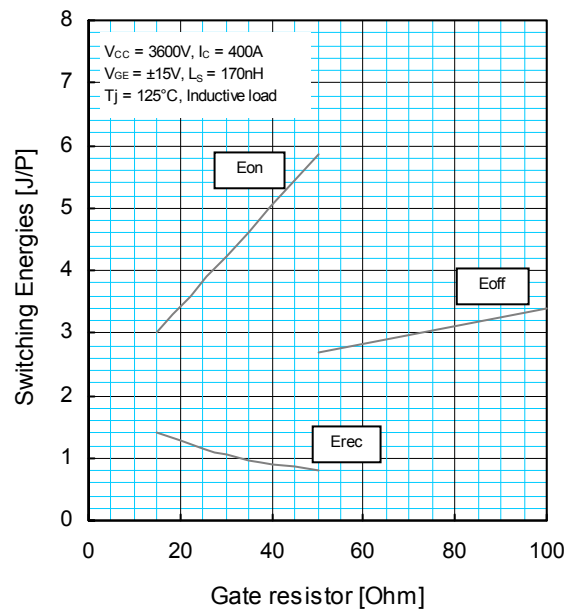

**PERFORMANCE CURVES**

**HALF-BRIDGE SWITCHING TIME CHARACTERISTICS (TYPICAL)**

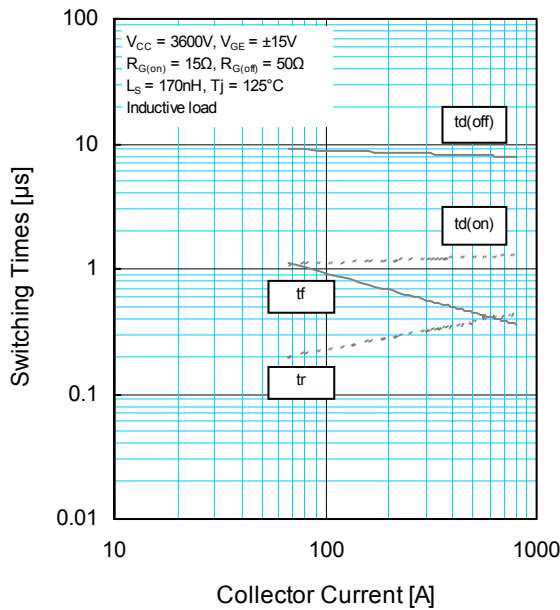

**FREE-WHEEL DIODE REVERSE RECOVERY CHARACTERISTICS (TYPICAL)**

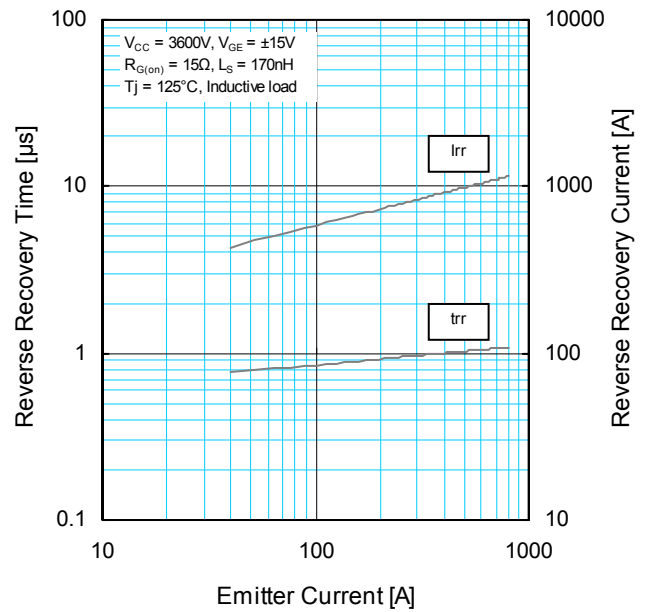

**TRANSIENT THERMAL IMPEDANCE CHARACTERISTICS**

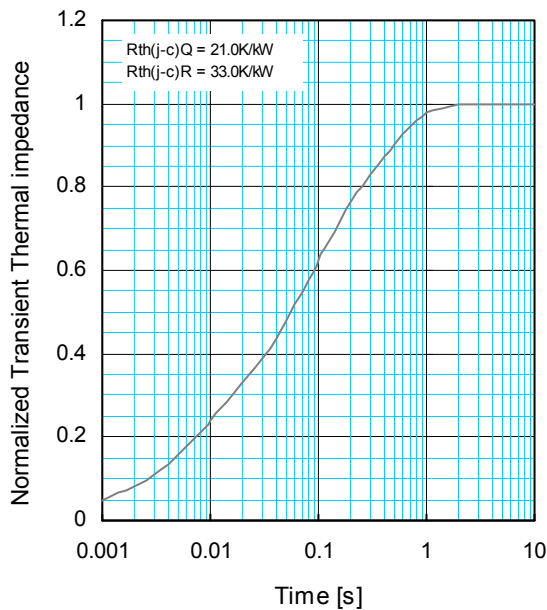

$$Z_{th(j-c)}(t) = \sum_{i=1}^n R_i \left\{ 1 - \exp\left(-\frac{t}{\tau_i}\right) \right\}$$

	1	2	3	4
$R_i$ [K/kW] :	0.0096	0.1893	0.4044	0.3967
$\tau_i$ [sec] :	0.0001	0.0058	0.0602	0.3512

# CM400E2G-130H

HIGH POWER SWITCHING USE  
INSULATED TYPE

3<sup>th</sup>-Version HVIGBT (High Voltage Insulated Gate Bipolar Transistor) Modules

## PERFORMANCE CURVES

**REVERSE BIAS SAFE OPERATING AREA (RBSOA)**

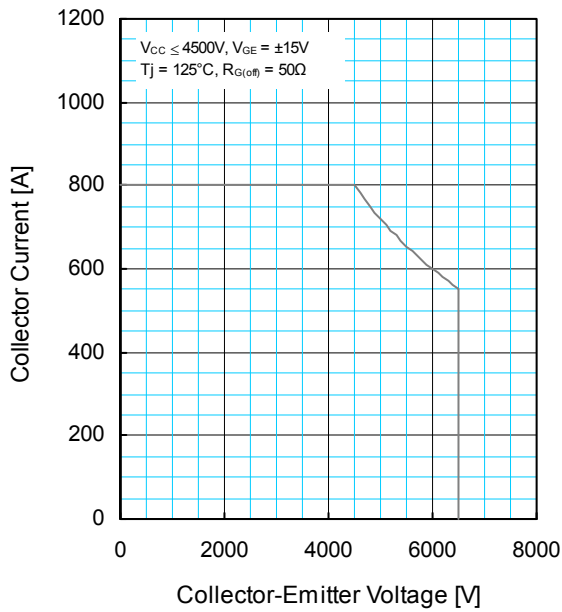

**SHORT CIRCUIT SAFE OPERATING AREA (SCSOA)**

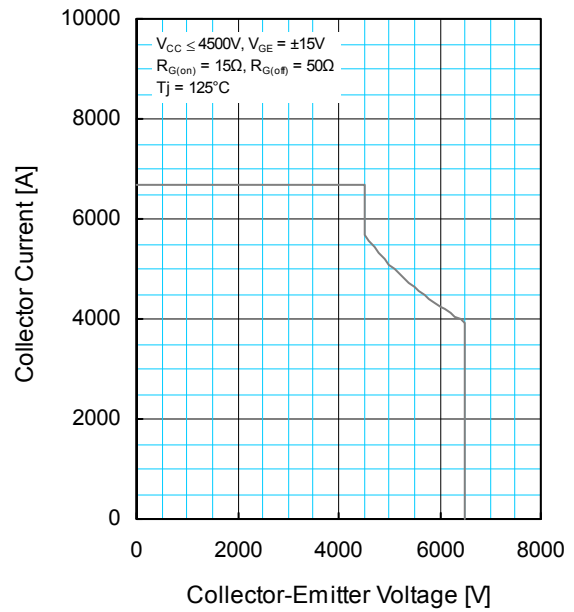

**FREE-WHEEL DIODE REVERSE RECOVERY SAFE OPERATING AREA (RRSOA)**

