

## Features

- Small SMD package: 2.0 x 1.2 mm (2012)<sup>[1]</sup>
- Pin-compatible to 2012 XTAL SMD package
- Ultra-low power: <1µA
- Supports coin-cell or super-cap battery backup voltages
- Vdd supply range: 1.5V to 3.63V over -40°C to +85°C
- Oscillator output eliminates external load caps
- NanoDrive™ programmable output swing for lowest power
- Internal filtering eliminates external Vdd bypass cap
- Fixed 32.768 kHz output frequency
- <20 PPM initial stability
- <100 PPM stability over -40°C to +85°C
- Pb-free, RoHS and REACH compliant

## Applications

- Mobile Phones
- Tablets
- Health and Wellness Monitors
- Fitness Watches
- Sport Video Cams
- Wireless Keypads
- Ultra-Small Notebook PC
- Pulse-per-Second (pps) Timekeeping
- RTC Reference Clock
- Battery Management Timekeeping

Note: 1. For the smallest 32 kHz XO in CSP (1.2mm<sup>2</sup>), consider the SiT1532



## Electrical Characteristics

Parameter	Symbol	Min.	Typ.	Max.	Unit	Condition
<b>Frequency and Stability</b>						
Fixed Output Frequency	F <sub>out</sub>		32.768		kHz	
<b>Frequency Stability</b>						
Frequency Stability <sup>[2]</sup>	F <sub>stab</sub>			20	PPM	T <sub>A</sub> = 25°C, Vdd: 1.5V – 3.63V
				75		T <sub>A</sub> = -10°C to +70°C, Vdd: 1.5V – 3.63V. Stability includes initial, power supply, and temperature stability components.
				100		T <sub>A</sub> = -40°C to +85°C, Vdd: 1.5V – 3.63V. Stability includes initial, power supply, and temperature stability components.
				250		T <sub>A</sub> = 10°C to +70°C, Vdd: 1.2V – 1.5V. Stability includes initial, power supply, and temperature stability components.
25°C Aging		-3		3	PPM	1st Year
<b>Supply Voltage and Current Consumption</b>						
Operating Supply Voltage	Vdd	1.2		3.63	V	T <sub>A</sub> = 10°C to +70°C
		1.5		3.63	V	T <sub>A</sub> = -40°C to +85°C
Power Supply Reset Voltage	Reset	0.3			V	
Core Operating Current <sup>[3, 4]</sup>	I <sub>dd</sub>		0.9		µA	T <sub>A</sub> = 25°C, Vdd: 1.5V – 3.63V. No load
				1.3		T <sub>A</sub> = -10°C to +70°C, Vdd max: 3.63V. No load
				1.35		T <sub>A</sub> = -40°C to +85°C, Vdd max: 3.63V. No load
Output Stage Operating Current <sup>[3]</sup>	I <sub>dd_out</sub>		0.065	0.125	µA/Vpp	T <sub>A</sub> = -40°C to +85°C, Vdd: 1.5V – 3.63V. No load
Power-Supply Ramp	t <sub>Vdd_Ramp</sub>			100	ms	T <sub>A</sub> = -40°C to +85°C, 0 to 100% Vdd
T <sub>START-UP</sub> at Power-up	T <sub>start</sub>		150	300	ms	T <sub>A</sub> = -40°C to +85°C
<b>Operating Temperature Range</b>						
Commercial Temperature	T <sub>use</sub>	-10		70	°C	
Industrial Temperature		-40		85	°C	
<b>LVCMOS Output Option, T<sub>A</sub> = -40°C to +85°C, typical value is T<sub>A</sub> = 25°C</b>						
Output Rise/Fall Time	t <sub>r</sub> , t <sub>f</sub>		100	200	ns	10-90%, 15 pF load, Vdd = 1.5V to 3.63V
Output Clock Duty Cycle	DC	48		52	%	
Output Voltage High	VOH	90%			V	Vdd: 1.5V – 3.63V. I <sub>OH</sub> = -10µA, 15 pF
Output Voltage Low	VOL			10%	V	Vdd: 1.5V – 3.63V. I <sub>OL</sub> = 10µA, 15 pF
<b>NanoDrive™ Programmable, Reduced Swing Output</b>						
Output Rise/Fall Time	t <sub>r</sub> , t <sub>f</sub>			200	ns	10-90%, 15 pF Load
Output Clock Duty Cycle	DC	48		52	%	
AC-coupled Programmable Output Swing	V <sub>sw</sub>	0.25		0.80	V	Vdd: 1.2V – 3.63V, 15 pF Load, 10 pF, I <sub>OH</sub> / I <sub>OL</sub> = ±0.2µA
DC-Biased Programmable Output Voltage High Range	VOH	0.5		1.20	V	Vdd: 1.2V – 3.63V. I <sub>OH</sub> = -0.2µA, 10 pF Load
DC-Biased Programmable Output Voltage Low Range	VOL	0.35		0.80	V	Vdd: 1.2V – 3.63V. I <sub>OH</sub> = 0.2µA, 10 pF Load

### Notes:

2. Stability is specified for two operating voltage ranges. Stability progressively degrades with supply voltage below 1.5V.
3. Core operating current does not include output driver operating current or load current.
4. To derive total operating current (no load), add core operating current + (0.065 µA/V) \* (peak-to-peak output Voltage swing).

### Electrical Characteristics (continued)

Parameter	Symbol	Min.	Typ.	Max.	Unit	Condition
<b>Jitter Performance (<math>T_A = 25^\circ\text{C}</math>, <math>V_{dd} = 1.5\text{V}</math> to <math>2.0\text{V}</math>, unless otherwise stated)</b>						
Period Jitter	T_djitt		45		ns <sub>RMS</sub>	N = 10,000

### Pin Configuration

Pin	Symbol	I/O	Functionality
1	NC	No Connect, don't care	No Connect. Will not respond to any input signal. This pin is typically connected to the receiving IC's X IN pin. In this case, the SiT1533 will not be affected by the signal on this pin.
2	GND	Power Supply Ground	Connect to ground.
3	CLK Out	OUT	Oscillator clock output. The CLK Out is typically connected to the receiving IC's X IN pin. The SiT1533 oscillator output includes an internal driver. As a result, the output swing and operation is not dependent on capacitive loading. This makes the output much more flexible, layout independent, and robust under changing environmental and manufacturing conditions.
4	Vdd	Power Supply	Connect to power supply $1.5\text{V} \leq V_{dd} \leq 3.63\text{V}$ for operation over $-40^\circ\text{C}$ to $+85^\circ\text{C}$ temperature range. Under normal operating conditions, Vdd does not require external bypass/decoupling capacitor(s). Contact factory for applications that require a wider operating supply voltage range.

SMD Package (Top View)

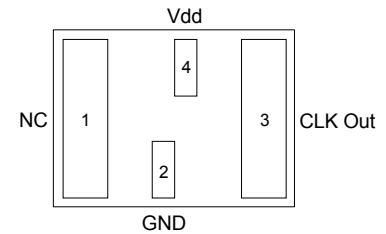

### System Block Diagram

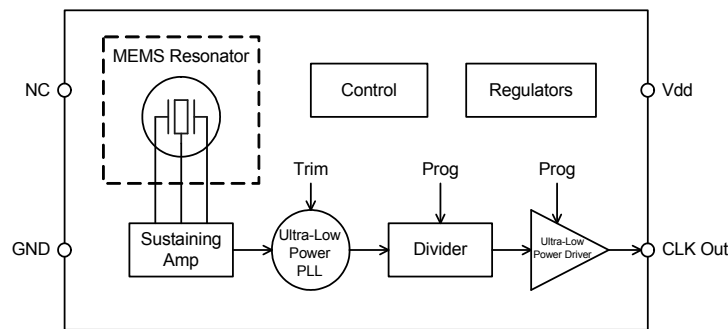

Figure 1.

### Absolute Maximum

Attempted operation outside the absolute maximum ratings of the part may cause permanent damage to the part. Actual performance of the IC is only guaranteed within the operational specifications, not at absolute maximum ratings.

Parameter	Symbol	Test Condition	Value	Unit
Power Supply Voltage Range (Vdd)	Vdd		-0.5 to 4	
ESD Protection		HBM 100pF, 1.5kΩ	2000	
ESD Protection		CDM, 25°C	750	
ESD Protection		MM, 25°C	200	
Power Supply Voltage Range (Vdd)	Vdd		-0.5 to 4	
Latch-up Tolerance			JESD78 Compliant	
Mechanical Shock Resistance	ΔF/F	Mil 883, Method 2002	TBD	g
Mechanical Vibration Resistance	ΔF/F	Mil 883, Method 2005	TBD	g
2012 SMD Junction Temperature			TBD	
Storage Temperature			-65°C to 150°C	

### Thermal Consideration

Package	θJA, 4 Layer Board (°C/W)	θJA, 2 Layer Board (°C/W)	θJC, Bottom (°C/W)
2012 SMD	TBD		

### Description

The SiT1533 is an ultra-small and ultra-low power 32.768 kHz oscillator optimized for mobile and other battery-powered applications. The SiT1533 is pin-compatible and footprint compatible to existing 2012 XTALs when using the SiTime solder-pad layout (SPL). And unlike standard oscillators, the SiT1533 features NanoDrive™, a factory programmable output that reduces the voltage swing to minimize power.

The 1.2V to 3.63V operating supply voltage range makes it an ideal solution for mobile applications that incorporate a low-voltage, battery-back-up source such as a coin-cell or super-cap.

### XTAL Footprint Compatibility (SMD Package)

The SiT1533 is a replacement to the 32 kHz XTAL in the 2.0 x 1.2 mm (2012) package. Unlike XTAL resonators, SiTime's silicon MEMS oscillators require a power supply (Vdd) and ground (GND) pin. Vdd and GND pins are conveniently placed between the two large XTAL pins. When using the SiTime Solder Pad Layout (SPL), the SiT1533 footprint is compatible with existing 32 kHz XTALs in the 2012 SMD package. Figure 2 shows the comparison between the quartz XTAL footprint and the SiTime footprint. For applications that require the smallest footprint solution, consider the SiT1532 XO available in a 1.2mm<sup>2</sup> CSP.

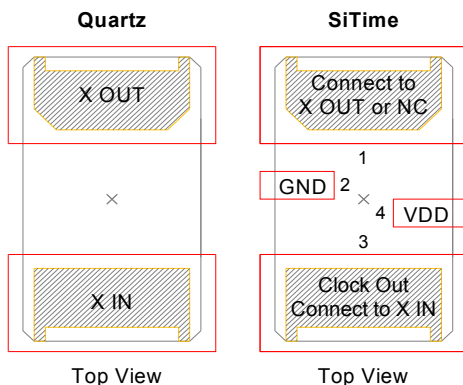

Figure 2. SiT1533 Footprint Compatibility with Quartz XTAL Footprint <sup>(5)</sup>

### Frequency Stability

The SiT1533 is factory calibrated (trimmed) to guarantee frequency stability to be less than 20 PPM at room temperature and less than 100 PPM over the full -40°C to +85°C temperature range. Unlike quartz crystals that have a classic tuning fork parabola temperature curve with a 25°C turnover point, the SiT1533 temperature coefficient is extremely flat across temperature. The device maintains less than 100 PPM frequency stability over the full operating temperature range when the operating voltage is between 1.5 and 3.63V. Contact SiTime for applications that require a wider supply voltage range >3.63V, or lower operating frequency below 32 kHz.

### Power Supply Noise Immunity

The SiT1533 is an ultra-small 32 kHz oscillator. In addition to eliminating external output load capacitors common with standard XTALs, this device includes special power supply filtering and thus, eliminates the need for an external Vdd bypass-decoupling capacitor. This feature further simplifies the design and keeps the footprint as small as possible. Internal power supply filtering is designed to reject AC-noise greater than ±150 mVpp magnitude and beyond 10 MHz frequency component.

### Output Voltage

For low-power applications that drive directly into a chip-set's XTAL input, the reduced swing output is ideal. SiTime's unique NanoDrive™, factory-programmable output stage is optimized for low voltage swing to minimize power and maintain compatibility with the downstream oscillator input (X IN pin). The SiT1533 output swing is customer specific and factory programmed between 250 mV and 800 mV. For DC-coupled applications, output V<sub>OH</sub> and V<sub>OL</sub> are individually factory programmed to the customers' requirement. V<sub>OH</sub> programming range is between 500 mV and 1.2V in 100 mV increments. Similarly, V<sub>OL</sub> programming range is between 350 mV and 800 mV. For DC-biased NanoDrive™ output configuration, the minimum V<sub>OL</sub> is limited to 350mV. For example, 1.1V V<sub>OH</sub> and 400mV V<sub>OL</sub> is acceptable, but 1.0V V<sub>OH</sub> and 350mV V<sub>OL</sub> is not acceptable. Contact SiTime for programming support.

**Note:**

5. On the SiTime device, X IN is not internally connected and will not respond to any signal. It is acceptable to connect to chipset X OUT.

## Calculating Load Current

### No Load Supply Current

When calculating no-load power for the SiT1533, the core and output driver components need to be added. Since the output voltage swing can be programmed for reduced swing between 250 mV and 800 mV for ultra-low power applications, the output driver current is variable. Therefore, no-load operating supply current is broken into two sections; core and output driver. The equation is as follows:

$$\text{Total Supply Current (no load)} = I_{dd} \text{ Core} + (65\text{nA/V})(V_{out\_pp})$$

#### **Example 1: Full-swing LVCMOS**

- Vdd = 1.8V
- Idd Core = 900nA (typ)
- Vout<sub>pp</sub> = 1.8V

$$\text{Supply Current} = 900\text{nA} + (65\text{nA/V})(1.8\text{V}) = 1047\text{nA}$$

#### **Example 2: NanoDrive™ Reduced Swing**

- Vdd = 1.8V
- Idd Core = 900nA (typ)
- Vout<sub>pp</sub> (Programmable) = V<sub>OH</sub> - V<sub>OL</sub> = 1.1V - 0.6V = 500mV

$$\text{Supply Current} = 900\text{nA} + (65\text{nA/V})(0.5\text{V}) = 832\text{nA}$$

## Total Supply Current with Load

To calculate the total supply current, including the load, follow the equation listed below. Note the 30% reduction in power with NanoDrive™.

$$\text{Total Current} = I_{dd} \text{ Core} + I_{dd} \text{ Output Driver} (65\text{nA/V} \cdot V_{out\_pp}) + \text{Load Current} (C \cdot V \cdot F)$$

#### **Example 1: Full-swing LVCMOS**

- Vdd = 1.8V
- Idd Core = 900nA
- Load Capacitance = 10pF
- Idd Output Driver: (65nA/V)(1.8V) = 117nA
- Load Current: (10pF)(1.8V)(32.768kHz) = 590nA
- Total Current = 900nA + 117nA + 590nA = 1.6μA

#### **Example 2: NanoDrive™ Reduced Swing**

- Vdd = 1.8V
- Idd Core = 900nA
- Load Capacitance = 10pF
- Vout<sub>pp</sub> (Programmable): V<sub>OH</sub> - V<sub>OL</sub> = 1.1V - 0.6V = 500mV
- Idd Output Driver: (65nA/V)(0.5V) = 33nA
- Load Current: (10pF)(0.5V)(32.768kHz) = 164nA
- Total Current = 900nA + 33nA + 164nA = 1.1μA

# SiT1533

Ultra-Low Power 32.768 kHz XTAL Replacement in 2.0 x 1.2 mm SMD



The Smart Timing Choice™

## Dimensions and Patterns

Package Size – Dimensions (Unit: mm)	Recommended Land Pattern (Unit: mm)
<p><b>2.0 x 1.2 mm SMD</b></p>	<p><b>SiTime Only SPL</b></p> <p><b>XTAL Compatible SPL</b></p>

## Ordering Information

Part number characters in blue represent the customer specific options. The other characters in the part number are fixed. Here are guidelines to select the correct output voltage.

- For XTAL replacement applications that will keep the chipset oscillator enabled, configure the NanoDrive™ output for a swing similar to the XTAL, approximately 250mV.  
→ SiT1533AI-H4-AA2-32.768
- For XTAL replacement applications that will disable the chipset oscillator, configure the output with one of the following:
  - For VDD = 1.8V: SiT1533AI-H4-D14-32.768
  - For VDD > 1.8V: SiT1533AI-H4-DCC-32.768

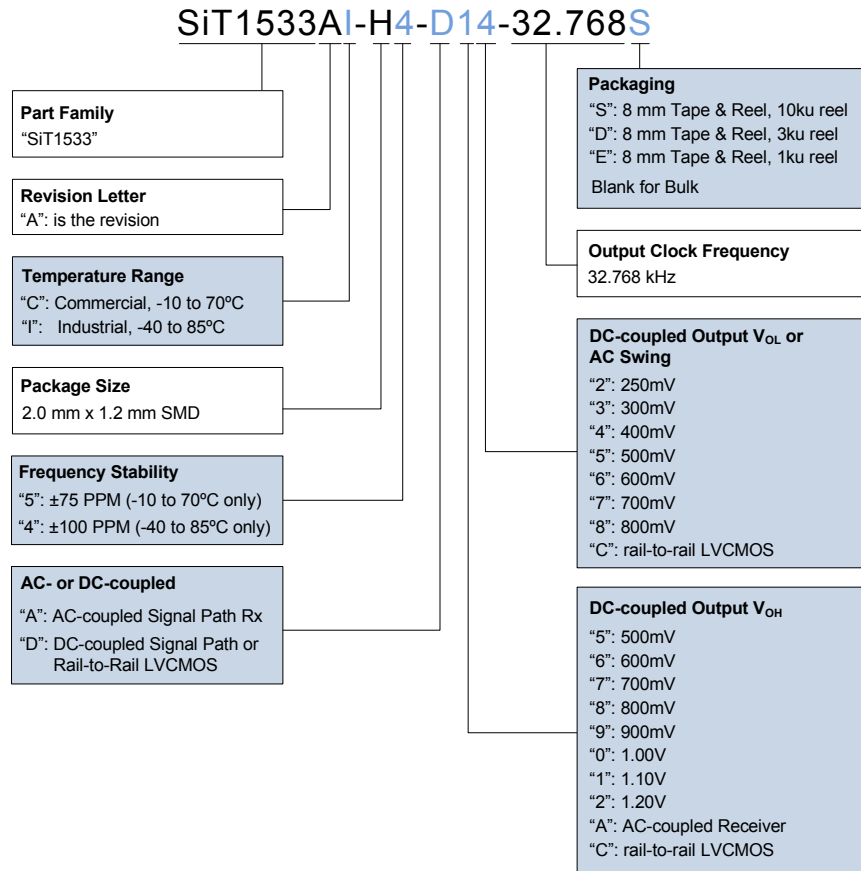

The following examples illustrate how to select the appropriate temp range and output voltage requirements:

### **Example 1: SiT1533AI-H4-D14-32.768**

- Industrial temp & corresponding 100 PPM frequency stability. Note, 100 PPM is only available for the industrial temp range, and 75 PPM is only available for the commercial temp range.
- Output swing requirements:
  - "D" = DC-coupled receiver
  - "1" =  $V_{OH}$  = 1.1V
  - "4" =  $V_{OL}$  = 0.4V

### **Example 2: SiT1533AC-H5-AA2-32.768**

- Commercial temp & corresponding 75 PPM frequency stability. Note, 100 PPM is only available for the industrial temp range, and 75 PPM is only available for the commercial temp range.
- Output swing requirements:
  - "A" = AC-coupled receiver
  - "A" = AC-coupled receiver
  - "2" = 250mV swing

---

© SiTime Corporation 2013. The information contained herein is subject to change at any time without notice. SiTime assumes no responsibility or liability for any loss, damage or defect of a Product which is caused in whole or in part by (i) use of any circuitry other than circuitry embodied in a SiTime product, (ii) misuse or abuse including static discharge, neglect or accident, (iii) unauthorized modification or repairs which have been soldered or altered during assembly and are not capable of being tested by SiTime under its normal test conditions, or (iv) improper installation, storage, handling, warehousing or transportation, or (v) being subjected to unusual physical, thermal, or electrical stress.

**Disclaimer:** SiTime makes no warranty of any kind, express or implied, with regard to this material, and specifically disclaims any and all express or implied warranties, either in fact or by operation of law, statutory or otherwise, including the implied warranties of merchantability and fitness for use or a particular purpose, and any implied warranty arising from course of dealing or usage of trade, as well as any common-law duties relating to accuracy or lack of negligence, with respect to this material, any SiTime product and any product documentation. Products sold by SiTime are not suitable or intended to be used in a life support application or component, to operate nuclear facilities, or in other mission critical applications where human life may be involved or at stake. All sales are made conditioned upon compliance with the critical uses policy set forth below.

**CRITICAL USE EXCLUSION POLICY**

BUYER AGREES NOT TO USE SITIME'S PRODUCTS FOR ANY APPLICATION OR IN ANY COMPONENTS USED IN LIFE SUPPORT DEVICES OR TO OPERATE NUCLEAR FACILITIES OR FOR USE IN OTHER MISSION-CRITICAL APPLICATIONS OR COMPONENTS WHERE HUMAN LIFE OR PROPERTY MAY BE AT STAKE.

SiTime owns all rights, title and interest to the intellectual property related to SiTime's products, including any software, firmware, copyright, patent, or trademark. The sale of SiTime products does not convey or imply any license under patent or other rights. SiTime retains the copyright and trademark rights in all documents, catalogs and plans supplied pursuant to or ancillary to the sale of products or services by SiTime. Unless otherwise agreed to in writing by SiTime, any reproduction, modification, translation, compilation, or representation of this material shall be strictly prohibited.