

Two Phase AC Transfer Switch Driver

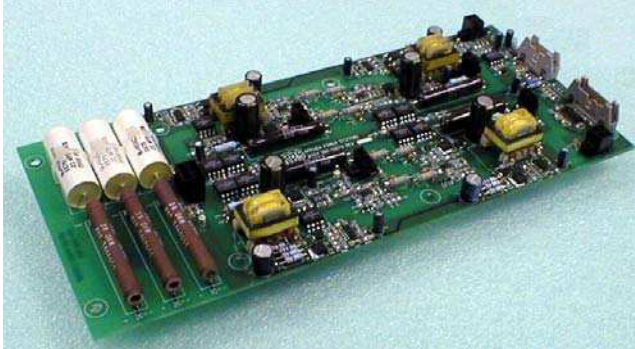

FEATURES

- ◆ Includes Four Individual SCR Gate Drivers
- ◆ DC Gate Drive for Firing Large Area Devices
- ◆ Four Isolated Power Supplies Produced From Single 24VDC Input
- ◆ Opto-Isolated Customer Interface
- ◆ SCR Short Circuit Detection Option
- ◆ On-Board Snubber Option
- ◆ Complete Electrical Isolation
- ◆ Rugged Design (Mil-STD Shock & Vibe)
- ◆ 60 or 400 Hz Operation

The BAP1367 Quad SCR Gate Driver provides complete gate drive control for four thyristors, configured individually or in anti-parallel as dual AC Switches. This driver accepts logic level control inputs and provides isolated DC drive current for each individual SCR.

Optional short circuit detection and device snubber circuits are provided on-board.

High CMRR optocouplers provide isolation between the customer supplied logic level control signals and the SCR gate drives.

APPLICATIONS

The BAP1367 board accepts a single 24VDC power input and generates four individually isolated power supplies providing the required output gate drives.

The PCB assembly measures 5.5" X 12.5".

ELECTRICAL SPECIFICATIONS

Absolute Maximum Ratings, Ta = 25°C unless otherwise specified

Parameter	Typical	Max	Min
T _{OP} - Operating Temperature (°C)	-	85	-10
T _{OS} - Storage Temperature (°C)	-	125	-20
V _{ISO} Electrical Isolation (VRMS for 1 min.)	-	2500	-

Electrical Characteristics, Ta = 25°C unless otherwise specified

Parameter	Typical	Max	Min
V _{CTL} - Input Control Voltage (Volts DC)	5	7	4
I _{CTL} - Input Control Current (mA)	15	20	10
V _{GATE} - Open Circuit GATE Voltage (Volts DC)	12		
I _{GATE} - Continuous Output GATE Current (mA)	500		
T _P - Propagation Delay Time (uSec)	1		
α - Duty Cycle (%)		Continuous	

ELECTRICAL CONNECTIONS

J1 – INPUT POWER

Pin No.	Signal Name	Function
1	N.C.	No Connection
2	N.C.	No Connection
3	+25 VDC	+24 VDC Power Input
4	GND	Power Ground
5	N.C.	No Connection
6	N.C.	No Connection

J2 – LOGIC & OPTION POWER

Pin No.	Signal Name	Function
1	+15 VDC	+15 VDC Power Input –for Short Circuit Detection Option
2	15 VDC RETURN	15 VDC Ground Return
3	-15 VDC	-15 VDC Power Input –for Short Circuit Detection Option
4	15 VDC RETURN	15 VDC Ground Return
5	LCUR+	+Load Current Feedback
6	LCUR-	-Load Current Feedback
7	+5 VDC	+5 VDC Logic Power Input
8	LOGIC GROUND	5 VDC Logic Ground Return

J3 – SCR CONTROL INPUT

Pin No.	Signal Name	Function	
1	SCR1 CTL (+)	SCR1 Control Signal (0V = Off / 5V = On)	SW1P+
2	SCR1 CTL RET (-)	SCR1 Control Return	SW1P-
3	SCR2 CTL (+)	SCR2 Control Signal (0V = Off / 5V = On)	SW1N+
4	SCR2 CTL RET (-)	SCR2 Control Return	SW1N-
5	SCR3 CTL (+)	SCR3 Control Signal (0V = Off / 5V = On)	SW2P+
6	SCR3 CTL RET (-)	SCR3 Control Return	SW2P-
7	SCR4 CTL (+)	SCR4 Control Signal (0V = Off / 5V = On)	SW2N+
8	SCR4 CTL RET (-)	SCR4 Control Return	SW2N-

J4 – FAULT STATUS OUTPUT

Pin No.	Signal Name	Function	
1	SW1 SHORTED (+)	SW1 Short Detection Signal (0V = OK / 5V = Shorted Fault)	SW1P+
2	LOGIC GROUND	5 VDC Logic Ground Return	SW1P-
3	SW2 SHORTED (+)	SW2 Short Detection Signal (0V = OK / 5V = Shorted Fault)	SW1N+
4	LOGIC GROUND	5 VDC Logic Ground Return	SW1N-
5 - 14	N.C.	No Connection	

J7 – CURRENT SENSE OPTION

Pin No.	Signal Name	Function
1	+15 VDC	+15 VDC Power Output – to external Current Sensor - Optional
2	-15 VDC	-15 VDC Power Output – to external Current Sensor - Optional
3	I FDBK	Current Sense Feedback Signal
4	15 VDC RETURN	15 VDC Ground Return

J8 – J9 – SCR1 & SCR2 GATE DRIVE

Pin No.	Signal Name	Function
J8-1	SCR1-K	SCR1 - CATHODE
J8-2	SCR1-G	SCR1 - GATE
J9-1	SCR2-K	SCR2 - CATHODE
J9-2	SCR2-G	SCR2 - GATE

J10 – J11 – SCR3 & SCR4 GATE DRIVE

Pin No.	Signal Name	Function
J10-1	SCR1-K	SCR3 - CATHODE
J10-2	SCR1-G	SCR3 - GATE
J11-1	SCR1-K	SCR4 - CATHODE
J11-2	SCR1-G	SCR4 - GATE

J12 & J13– SNUBBER CONNECT OPTION

Pin No.	Signal Name	Function
J12-1 TO J13-1	R1-C1	R1-C1 Snubber Connection
J12-5 TO J13-5	R2-C2	R2-C2 Snubber Connection
J12-8 TO J13-8	R3-C3	R3-C3 Snubber Connection
2,3,4,6,7,9	N.C.	No Connection

BAP1367 Quad SCR Driver – Configured for dual AC switch operation

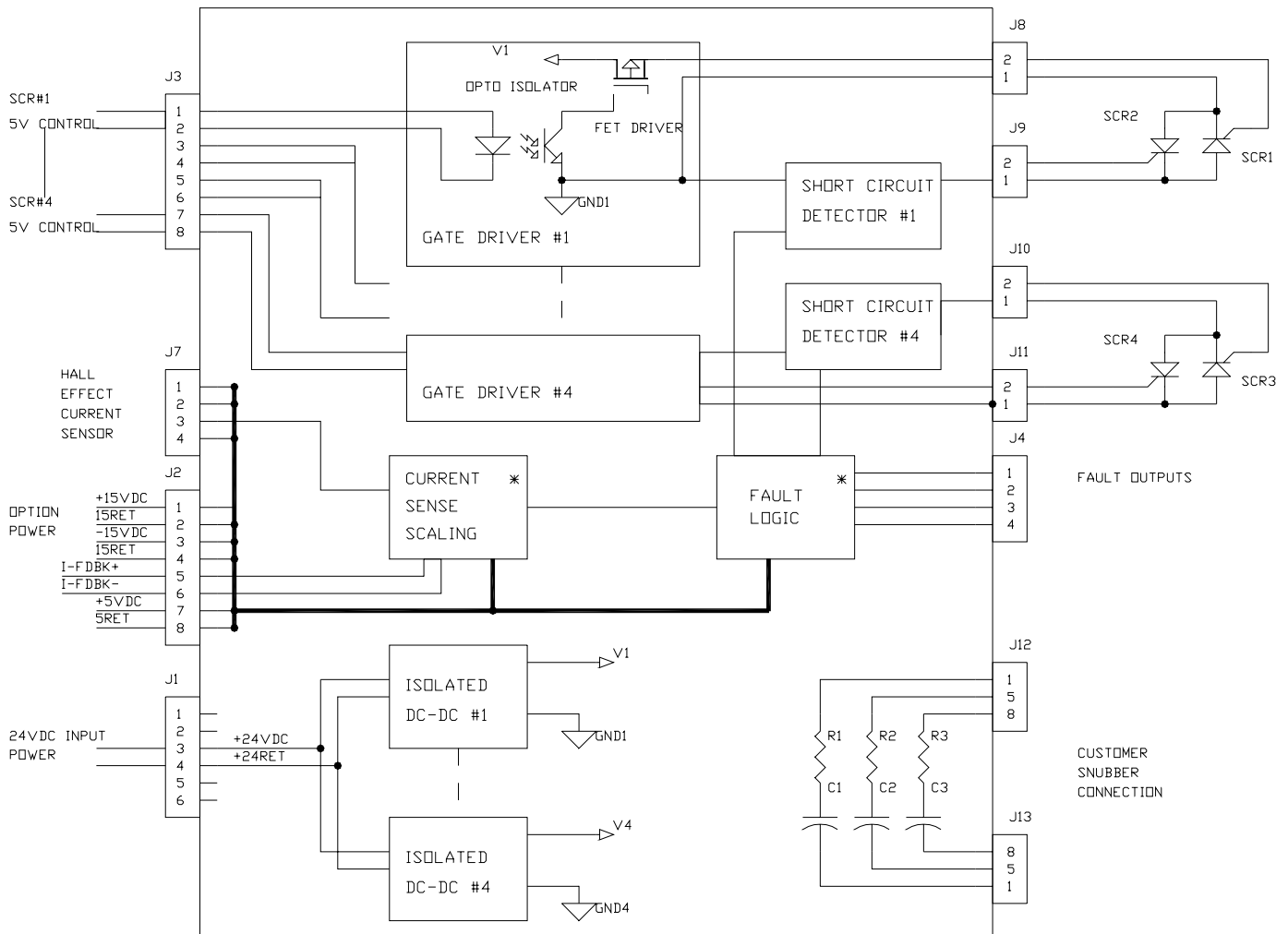

* SHORT CIRCUIT DETECT AND FAULT LOGIC CIRCUITS ONLY AVAILABLE WHEN CONFIGURED FOR AC SWITCH OPERATION.

MECHANICAL OUTLINE

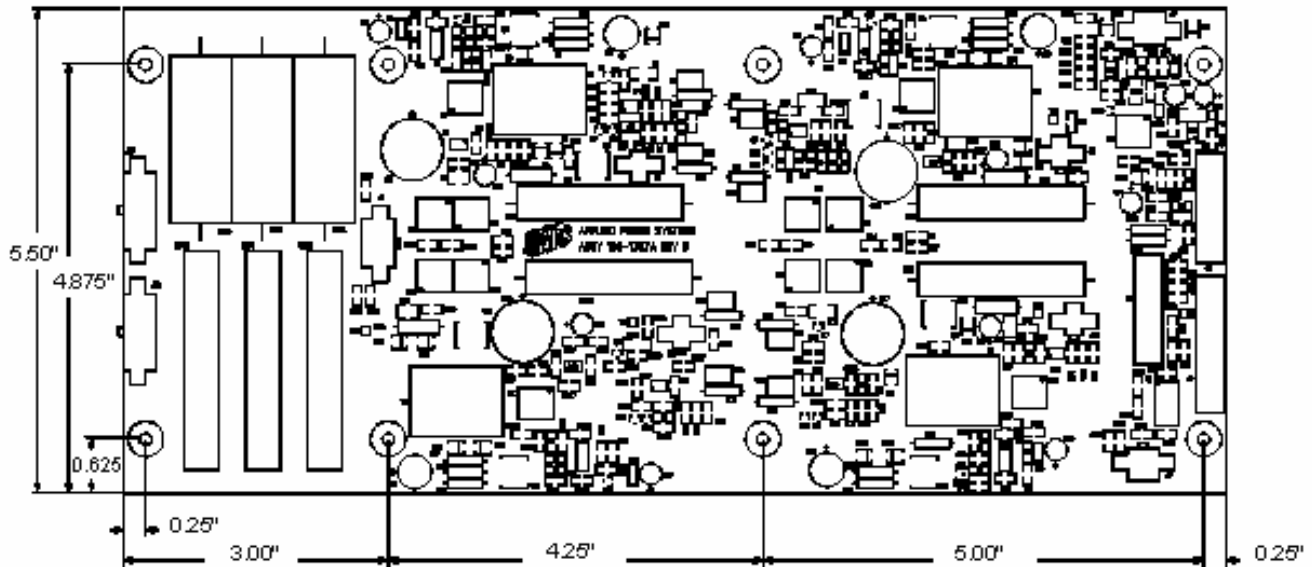

Max Board Height
1.50"

Mating Connectors:

- J1 - MOLEX P/N 15-97-5061
- J2 & J3 - FCI P/N 71600-008
- J4 - FCI P/N 71600-014
- J5 & J7 - MOLEX P/N 15-97-5041
- J8 - J11 - MOLEX P/N 15-97-5021
- J12 - J13 - MOLEX P/N 15-97-5101

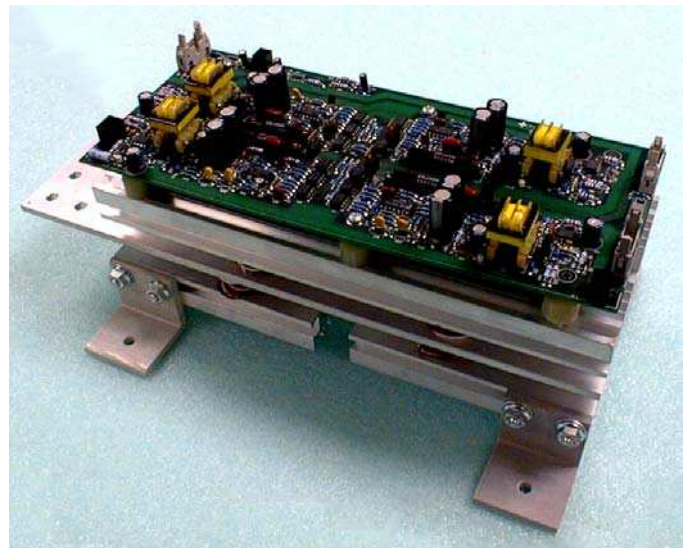

Typical Transfer Switch

Shown complete with BAP1367 Driver
mounted above Quad SCR Assembly