

BAP-1106 SCR GATE DRIVER

The BAP-1106 provides a complete, field-tested turnkey solution to drive a single large area thyristor device. This driver accepts a logic level control input and provides an isolated DC drive current into the SCR gate, able to hard drive up to 100mm size devices. The output gate drive signal is applied thru a pulse forming network that creates a fast rising leading edge current pulse (typically 5A/μSec) into the SCR gate, maximizing the device di/dt capability and insuring proper SCR turn on. The on board 115VAC power supply provides all needed power to drive the SCR and provides transformer isolation between the AC input and the SCR being driven. A high-speed optocoupler provides isolation between the customer supplied logic level signal and the SCR. LED indicators display POWER ON and SCR ON status. The small footprint PCB assembly measures only 3.0" X 5.0".

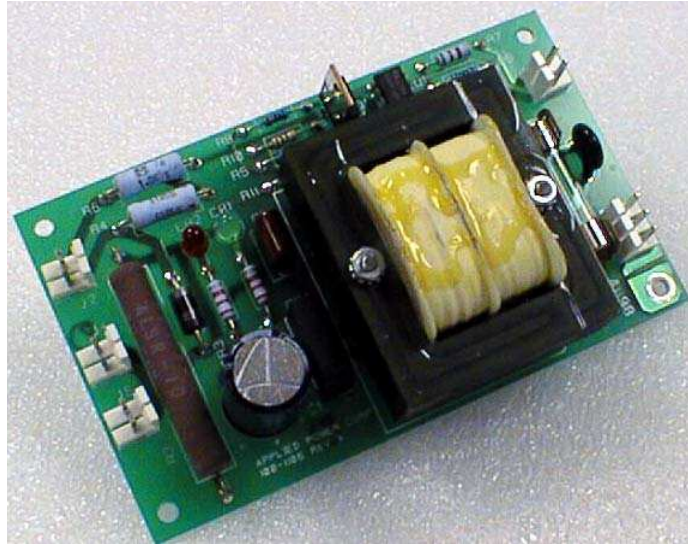

CIRCUIT DIAGRAM

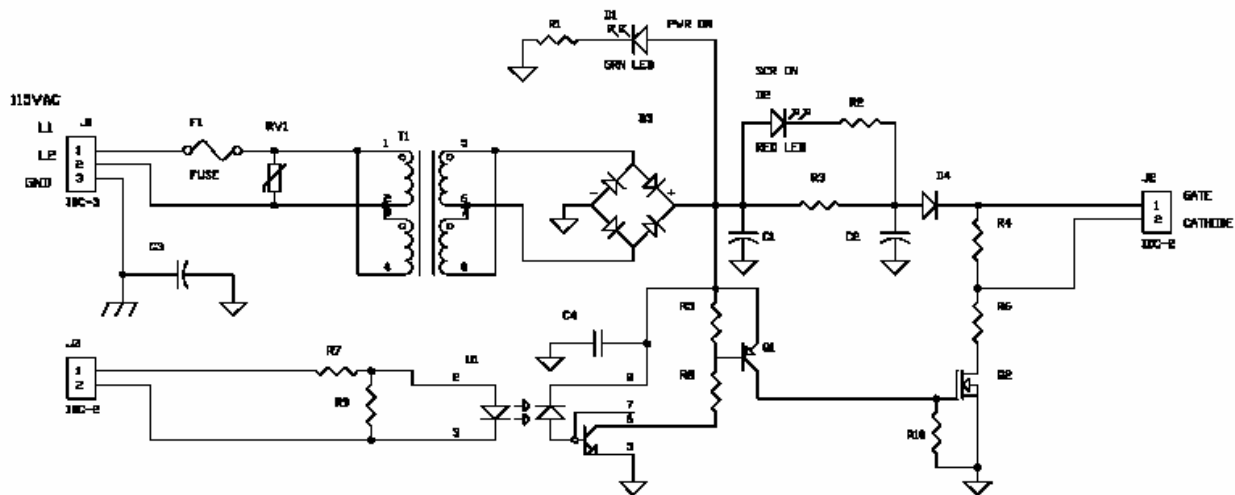

ELECTRICAL SPECIFICATIONS

Absolute Maximum Ratings, $T_a = 25^\circ\text{C}$ unless otherwise specified

Parameter	Typical	Max	Min
T_{OP} - Operating Temperature ($^\circ\text{C}$)	-	70	-10
T_{OS} - Storage Temperature ($^\circ\text{C}$)	-	85	-20
V_{ISO} - Electrical Isolation (VRMS for 1 min.)	-	2500	-

Electrical Characteristics, $T_a = 25^\circ\text{C}$ unless otherwise specified

Parameter	Typical	Max	Min
V_{CTL} - Input Control Voltage (Volts DC)	12	24	10
I_{CTL} - Input Control Current (mA)	20	40	16
V_{GATE} - Open Circuit GATE Voltage (Volts DC)	16		
I_{GATE} - Continuous Output GATE Current (mA)	500		
I_{GPK} - Peak Output GATE Current (Amperes)	8		
T_P - Propagation Delay Time (μSec)	1		
α - Duty Cycle (%)		Continuous	

J1 - INPUT POWER

Pin No.	Signal Name	Function
1	AC HOT	115 VAC-L1 Input - 2A Fuse on board
2	AC NEUTRAL	115 VAC-L2 Input
3	AC CHASSIS GND	115 VAC Chassis Ground

J2 - SCR DRIVE OUTPUT

Pin No.	Signal Name	Function
1	SCR-GATE	GATE Drive Current High
2	SCR-CATHODE	GATE Drive Current Return

J3 - CONTROL INPUT

Pin No.	Signal Name	Function
1	CTL (+)	SCR Control Signal (0V = Off / 12V = On)
2	CTL RET (-)	SCR Control Return

MECHANICAL OUTLINE

Mating Connectors:

J1 - 640427-3

J2 - 640427-2

J3 - 640427-2

AMP MTA.156" IDC Conn.
or equivalent

Maximum Board Height:

1.5"

