

### BAP1289 HIGH VOLTAGE ISOLATED SCR GATE DRIVER

The BAP1289 provides a complete, reliable, turnkey solution to control single or multiple **High Voltage SCR** devices.

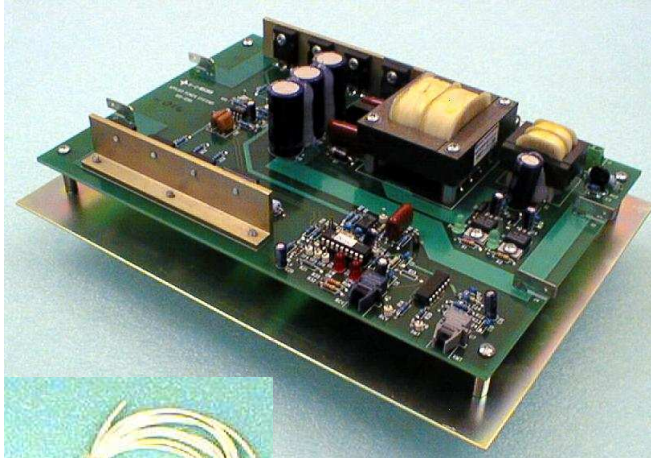

High current FET amplifiers drive individual pulse transformers that provide direct drive to each SCR gate. These encapsulated, corona resistant, high voltage pulse transformers are easily linked with supplied high voltage silicon wire to allow series stacking of multiple SCRs in order to obtain higher voltage operation.

Standard *Hewlett-Packard*™ fiber-optic couplers provide an intrinsically safe interface and virtually infinite noise immunity between the SCR being driven and the customers' control electronics.



An on-board microcontroller provides timing and control of the SCR gating signals with crystal controlled accuracy, allowing precision phase control of the SCR being driven.

An on-board power supply accepts 120VAC input and generates all power needed for the logic control, fiber-optic interface and gate drive.

15kV Pulse Transformer

#### APPLICATIONS

- ◆ Series SCR Stacks
- ◆ Parallel SCR Arrays
- ◆ AC Transfer Switches
- ◆ Medium to High Voltage Power Supply
- ◆ Rectifiers for High Energy Physics
- ◆ Pulsed Power Systems

#### FEATURES

- ◆ Drive Multiple Devices in Series Stack or Parallel Configuration
- ◆ Complete Electrical Isolation
- ◆ Fiber-Optic Customer Interface
- ◆ User-Definable Fiber-Optic Output
- ◆ 15 A Peak Gate Current
- ◆ 10 A/uS  $di/dt$  Gate Current
- ◆ Pulse Transformer Isolation
- ◆ High Voltage Corona Resistant > 15Kv
- ◆ High Open Circuit Gate Voltage
- ◆ On-Board Power Supply Included

## HIGH VOLTAGE SCR GATE DRIVER BLOCK DIAGRAM

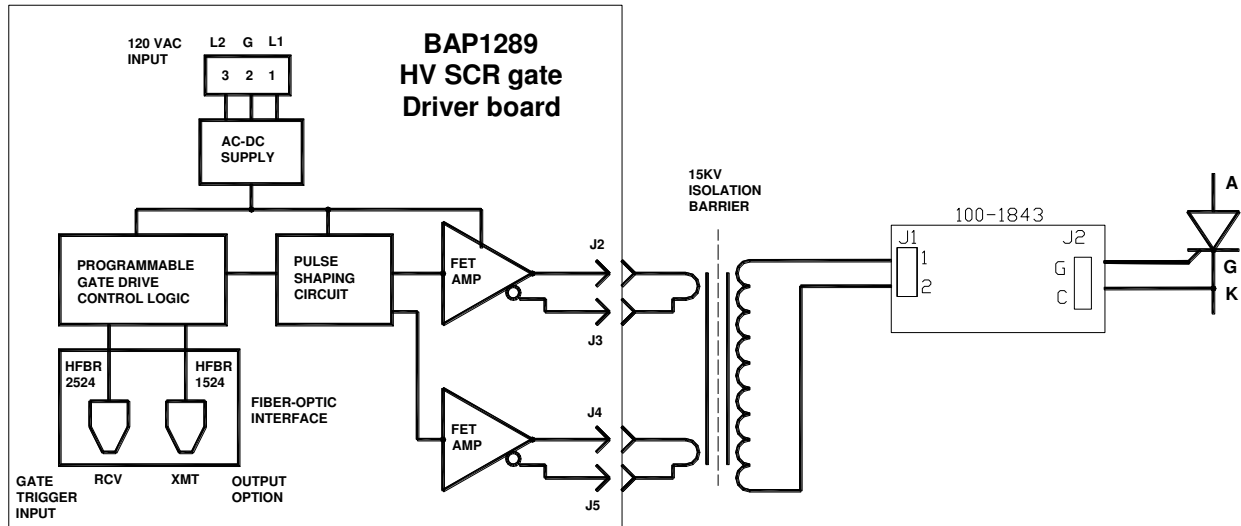

### TEST POINTS

TP1	Black	LOGIC GROUND
TP2	White	AC REFERENCE
TP3	White	CONTROL Input (Active High when Fiber-optic signal on)
TP7	White	SCR TRIGGER #1 (Buffered Trigger Drive)
TP9	White	CONTROL Output (Active Low when Fiber-optic signal on)
TP10	White	SCR TRIGGER #2 (Buffered Trigger Drive)

### LED STATUS INDICATORS

D1	+5V P.S.	ON = Power Supply OK / OFF = FAULT
D4	+15V P.S.	ON = Power Supply OK / OFF = FAULT
D13	CPU RUN	Normal Operation = Flashing LED (after 4 second Power-on delay).
D14	SCR ON	ON = CONTROL input signal active / OFF = CONTROL signal off.

### OPERATION

After an initial 4 second Power-On delay, LED D13 (CPU Run) will flash to indicate control logic is functioning. When an optical input signal is applied to the RCV input, the BAP-1289 generates a firing pulse into the primary of the pulse transformer. The pulse transformers isolated secondary drives the SCR gate input.

120 VAC Input Power should be applied to the Control board for 4 seconds minimum, prior to energizing the SCR being controlled. AC power to the board must be maintained during the entire operating period.

## ELECTRICAL SPECIFICATIONS

Electrical / Optical Characteristics, Ta = 25°C unless otherwise specified

Parameter		Typical	Max	Min
V <sub>IN</sub> – Supply Voltage	(Volts AC)	115	-	-
P <sub>IN</sub> – Supply Power	(Watts)		50	
di/dt – Gate Pulse	(Amps/uSec)	10		
V <sub>OM</sub> – Maximum Open Circuit Gate Voltage	(Volts)	80		
P <sub>T</sub> – Transmitter Output Optical Power	(dBm)		-5.1	-15.5
P <sub>R(L)</sub> – Receiver Optical Input Power Level Logic 0	(dBm)			-20
P <sub>R(H)</sub> – Receiver Optical Input Power Level Logic 1	(dBm)		-43	
λ <sub>PK</sub> – Peak Emission Wavelength	(nm)	660		
D <sub>T</sub> – Effective Diameter	(mm)	1		
t <sub>PLH</sub> – Propagation Time	(μS)	0.5	1.2	
t <sub>PHL</sub> – Propagation Time	(μS)	0.5	1.2	
t <sub>R</sub> – Rise Time	(μS)	0.3	0.6	
t <sub>F</sub> – Fall Time	(μS)	0.3	0.6	

## Control Interface Definitions

Conn No.	Signal Name	Function
U5	RCV	SCR CTL IN - Fiber-Optic SCR On/Off Control Input (LED On = SCR On)
U7	XMT	SCR CTL OUT - Fiber-Optic Buffered Control Output (Optional use – Consult Factory for details)
J1-1	AC HOT	120VAC Input – L1
J1-2	AC CHASSIS GND	120VAC Chassis Ground Input – G
J1-3	AC NEUTRAL	120VAC Input – L2

## MECHANICAL OUTLINE

Maximum Board Height  
1.50"

Mating Latching Connector:  
HFBR-4532

Fiber-Optic Cable:  
1mm POF

Mating Couplers:  
Transmitter: HFBR-2524  
Receiver: HFBR-1524

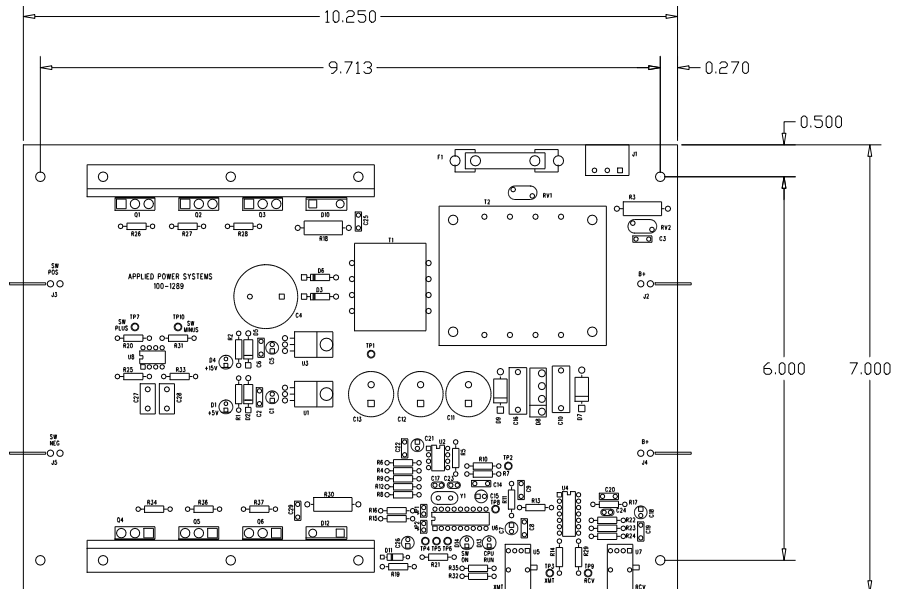

### Wiring Instructions for using the BAP1289 control board to fire a series string of SCRs

The BAP1289 high voltage SCR gate drive system consists of three components: the BAP1289 triggering board (one per system); the high voltage transformer (one for each SCR being fired in the series string); and the 100-1843 SCR gate firing circuit (one for each SCR being fired in the series string). These components must be connected in the following manner:

1. Each pulse transformer has two, external 4-turn windings. Connect the windings on each side of the pulse transformers in parallel as shown in illustration below. This requires tying all of the side terminals on one side together and tying all of the side terminals on the other side together. Also, tie all of the top terminals on one side together and tie all of the top terminals on the other side together.
2. Connect J3 and J5 on the BAP1289 board to the top screw terminals of the pulse transformers.
3. Connect J4 and J2 on the BAP1289 board to the side screw terminals of the pulse transformer.
4. Connect the 16 AWG twisted pair from the pulse transformer to J1 on the 100-1843 driver board. Since these wires carry an AC signal feeding a full bridge, the wires can go to either terminal.
5. Connect the gate lead of the SCR to J2-G on the 100-1843 driver board.
6. Connect the cathode potential lead on the SCR to J2-C on the 100-1843 driver board.
7. Connect J1-1 on the BAP1289 board to 120 VAC HOT.
8. Connect J1-2 on the BAP1289 board to GND.
9. Connect J1-3 on the 100-1289 board to 120 VAC NEUTRAL.

