

AP-1174 ISOLATED INTERFACE BOARD FOR *POWEREX* DUAL IPM MODULES

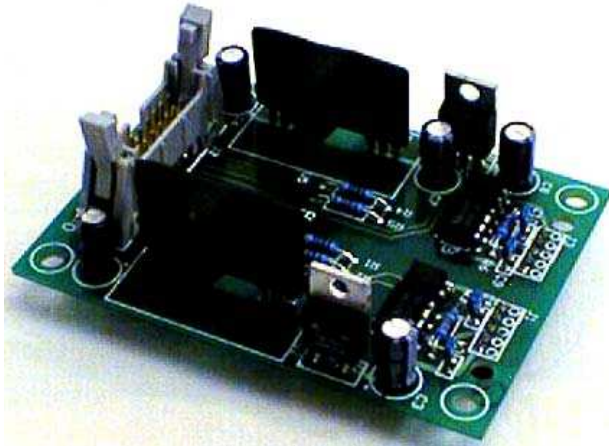

The BAP1174 provides a complete, tested, fast time-to-market solution for customers who need to interface to **POWEREX** V-Series Dual IPM modules.

The BAP1174 incorporates two isolated DC-DC converters which supply power to the IPM module. High speed optocouplers provide the proper interface between the module and the customers' control electronics. The assembly provides direct mounting to the IPM module and is packaged in a small footprint printed circuit board that measures only 2.50" X 3.40".

The BAP1174 supports the following IPM modules:

PM200DVA120
PM300DVA120
PM400DVA060
PM600DVA060

BLOCK DIAGRAM

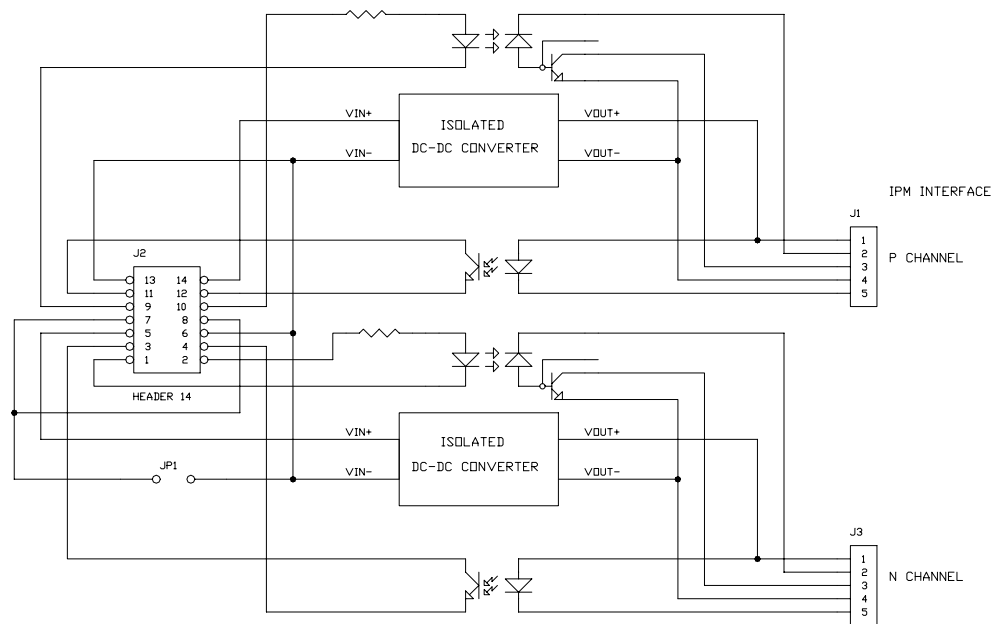

ELECTRICAL SPECIFICATIONS

Absolute Maximum Ratings, Ta = 25°C unless otherwise specified

Parameter		Typical	Max	Min
V _{IN} - Input Voltage	(Volts DC)		18	
T _{OP} - Operating Temperature	(°C)	-	70	-10
T _{OS} - Storage Temperature	(°C)	-	85	-20
V _{ISO} Electrical Isolation	(VRMS for 1 min.)	-	2500	-

Electrical Characteristics, Ta = 25°C, VIN = 15V unless otherwise specified

Parameter		Typical	Max	Min
V _{IN} - Input Voltage	(Volts DC)	15	18	12
I _{IN} - Input Current	(mA)		250	
V _{ON} - ON Control Voltage	(Volts DC)	12		
I _{CTL} - Control Current	(mA)	16		
V _{CE FLT} - Fault Output Voltage	(Volts DC)		30	
I _{C FLT} - Fault Output Current	(mA)		10	
V _R - Reverse Voltage	(Volts DC)		-5	

J2 - CONTROL INTERFACE CONNECTOR

Pin No.	Signal Name	Function
1	N-IGBT CTL RET	N Channel IGBT On/Off Control Return
2	N-IGBT CTL (+)	N Channel IGBT On/Off Control Signal (0 VDC = Off / 12 VDC = On)
3	N-IGBT FAULT (+)	N Channel IGBT Optoisolator Fault Output - Collector (Fault = Output Closed)
4	N-IGBT FAULT (-)	N Channel IGBT Optoisolator Fault Output - Emitter
5	VIN +	Input Voltage (12 - 18 VDC)
6	VIN -	Input Voltage Return (Ground)
7	JP1	JP1 Installed = Ground
8	JP1	JP1 Installed = Ground
9	P-IGBT CTL RET	P Channel IGBT On/Off Control Return
10	P-IGBT CTL (+)	P Channel IGBT On/Off Control Signal (0 VDC = Off / 12 VDC = On)
11	P-IGBT FAULT (+)	P Channel IGBT Optoisolator Fault Output - Collector (Fault = Output Closed)
12	P-IGBT FAULT (-)	P Channel IGBT Optoisolator Fault Output - Emitter
13	VIN +	Input Voltage (12 - 18 VDC)
14	VIN -	Input Voltage Return (Ground)

MECHANICAL OUTLINE

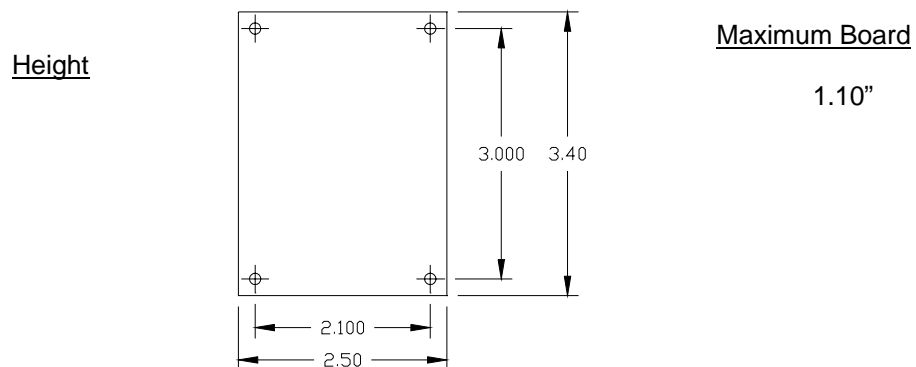

Mating Connector:
3M P/N 3385-7600
or equivalent