

## CAP6636 AC-DC Converter

### Description:

The CAP6636-CL is a three-phase AC to DC closed loop Converter assembly. The assembly includes the three-phase SCR converter bridge, a free wheeling diode, the thermal management system, a BAP1950 SCR phase control gate firing board, an R-C-MOV snubber for each SCR, Hall Effect current transducer and all bus work. It is rated at 150 Amps output and up to 660 volts AC input at 50 or 60 Hz.

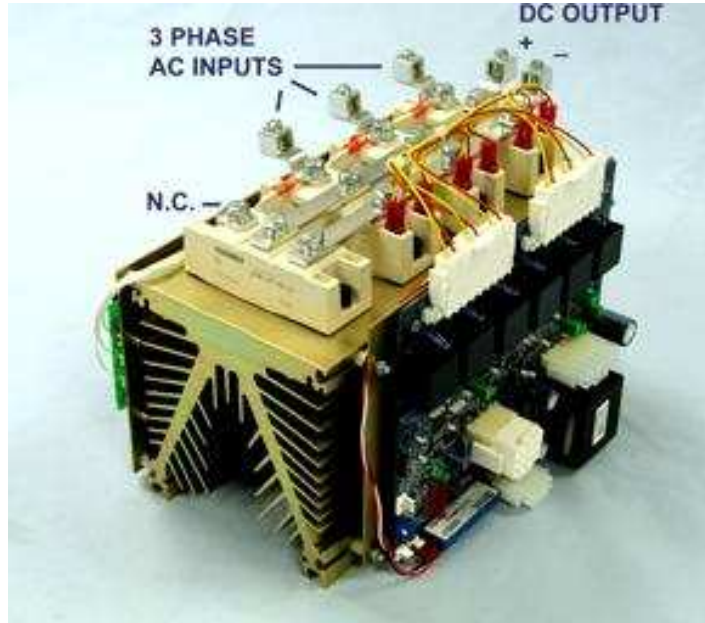

Typical use for the CAP6636-CL is as an AC-DC converter for OEM equipment; boost charger power supplies for rail and many other applications. The CAP6636-CL is voltage limited and current regulated for precision DC applications.

Contact APS for higher power system requirements.

### Specifications:

#### Input

Parameter	Min	Typ	Max	Units
Ambient Temperature	-40		50	°C
Input AC Voltage	50	480	660	Volts
Frequency	47	60	77	Hz

#### SCR Modules

Parameter	Min	Typ	Max	Units
Average Current		125	150	Amps
One cycle peak current			4,000	Amps
Blocking Voltage			1,600	Volts
Module Isolation Voltage	3,500			Volts
dV/dt	1,000			V/μs
dI/dt (non-repetitive)	300			A/μs

## BAP1950 Gate Firing Board Power Requirements

Parameter	Min	Typ	Max	Units
Input Voltage <sup>1</sup>	100	115	130	Vac
Power rating			24	VA

## Converter Output

Parameter	Min	Typ	Max	Units
Output Voltage	0		900	Vdc
Current	0		150	Amps
Ripple Frequency (at 60 Hz)		360		Hz

## Isolation

The low level signal inputs are isolated from the high level DC output and AC input in the following manner:

Isolation	Isolation Method
AC Supply	The AC supply is sensed through a resistor voltage divider with a 1meg $\Omega$ isolation resistance on each phase.
AC Supply and DC Load	5,000V <sub>ac</sub> (60 sec.) – rating from gate pulse transformers
DC Load	1500V <sub>rms</sub> (cont.) rating of isolation amplifier
BAP1950 Input Power	2500V <sub>ac</sub> (1 min.) from input transformer on board.

## Feedback Signals

Feedback Signal	Impedance
Rectifier Output Voltage	Attenuator voltage generated across 1Meg $\Omega$ resistor
Rectifier Current	50A:4.00V ratio from Hall Effect current transducer on the assembly

<sup>1</sup> Other input voltages are available. Please consult APS for further information.

## J3 – Customer Control Interface

Pin	Signal Name	Color	Description
1	24 VAC		From secondary winding of T2. 250mA available for customer use.
2	24 VAC		From secondary winding of T2. 250mA available for customer use.
3	24 VDC		250mA available for customer use.
4	Fast Turn off	Yellow	Shorting this signal to pin 6 or 7 enables gate pulses. Letting it float will disable the gating signals within 20uS.
5	Master/Slave		This pin is used when 2 or more boards are configured as Master/Slaves.
6	15 VDC		50mA available for customer use.
7	5 VDC	Red	50mA available for customer use.
8	GND	Black	Reference for AP1950 control circuitry, including Delay Angle Control. Therefore, it must be tied to the reference of a customer provided Delay Angle Control signal.
9	Inhibit Enunciate		Normally low (through a 1K resistor). Transitions high in a Fast Turn off or in an out of phase lock condition.
10	Delay Angle Control	White	0 to 5V analog input to control the delay angle. 0V→ Max Delay Angle (corresponding to minimum output voltage); 5V→ Min Delay Angle (corresponding to maximum output voltage).
11	GND	Black	Reference for AP1950 control circuitry, including Delay Angle Control. Therefore, it must be tied to the reference of a customer provided Delay Angle Control signal.
12	Soft Start/Stop	Blue	When this signal transitions from a contact closure to GND (pin 11 or 8) to an open circuit, the delay angle ramps down from maximum to the programmed value. If control power is applied to the AP1950, a transition from an open circuit to a contact closure to GND, the delay angle ramps up from the programmed value to the max value (minimum output voltage).

Signals with an assigned color are provided in the connector. If additional signals are to be used, the AMP contact part number is 350550-1 and the part number for the recommended crimping tool from AMP is 91500-1.

If a potentiometer will be used to control the delay angle, use the setup below.

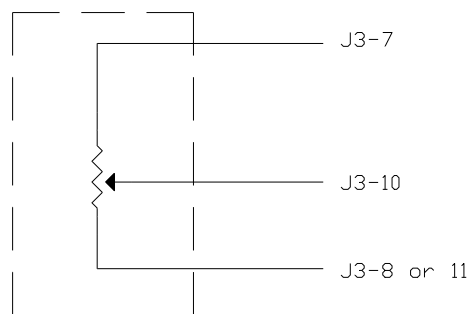

Customer provided  
Potentiometer

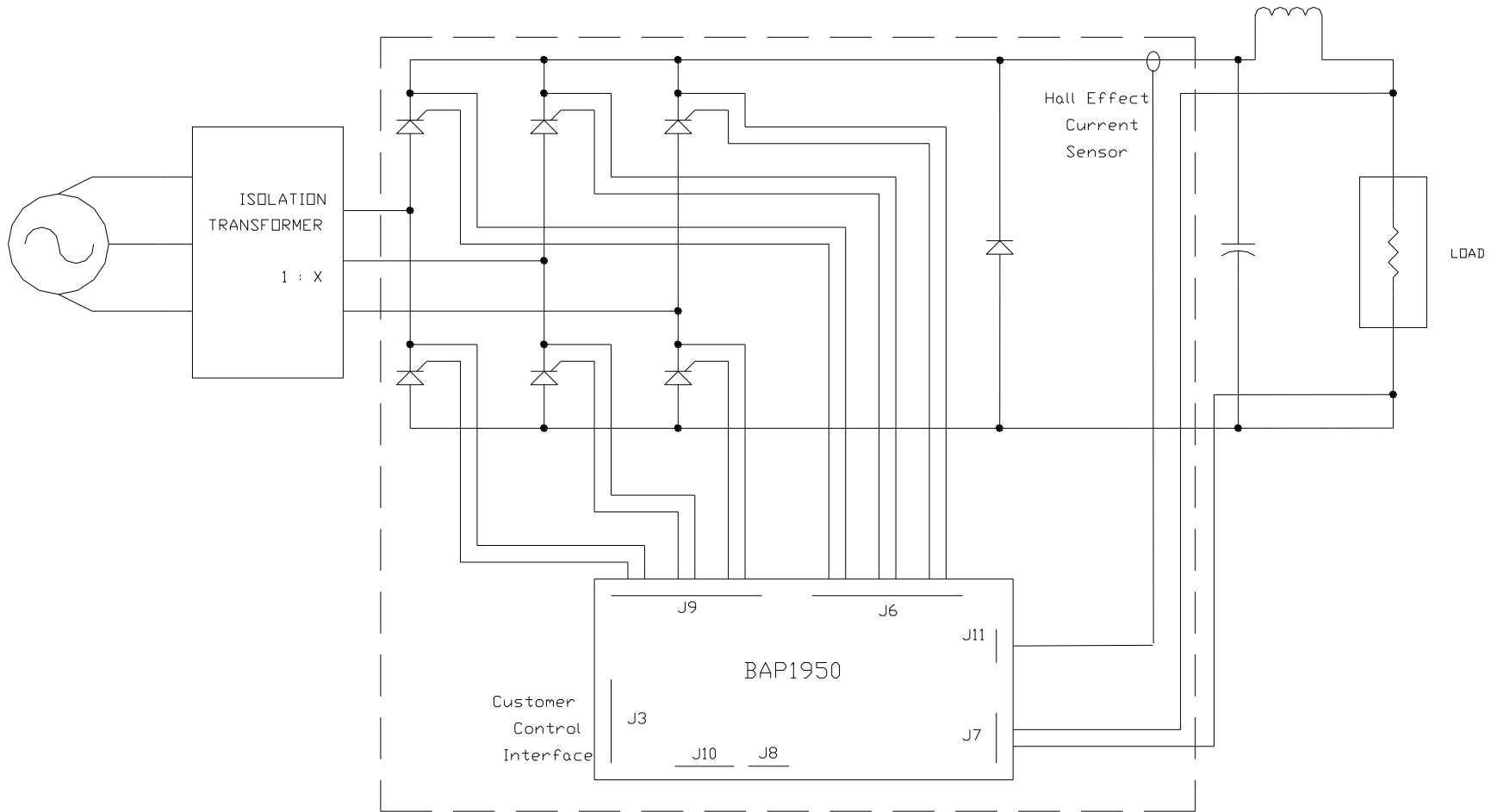

**Schematic of Closed Loop Feedback System**

