

**IAP1000D170H - Half-Bridge SixPac™
IGBT Integrated Assembly**

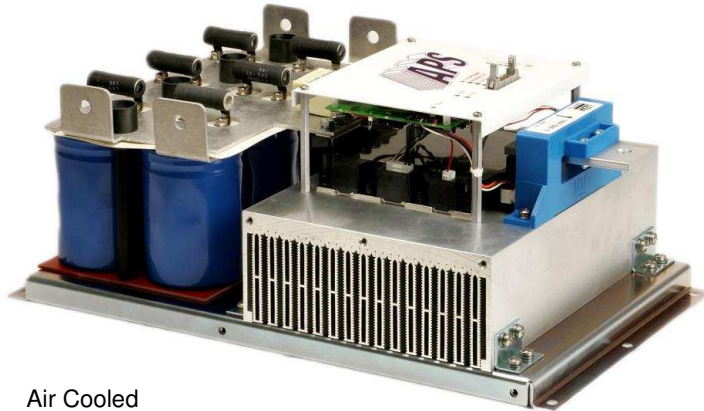

Air Cooled

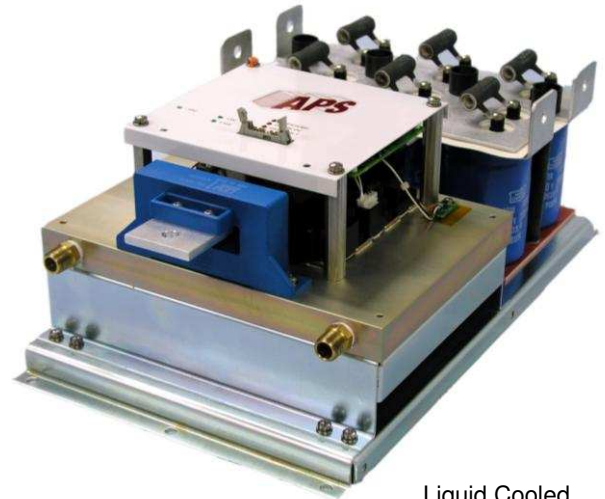

Liquid Cooled

Description:

The SixPac™ from Applied Power Systems is a configurable IGBT based power stage that is configured as a half-bridge for many high power applications. The IAP1000D170 can be used as a chopper for motor braking or two can be used in a full-bridge inverter application. Three IAP1000D170s can be used as a three-phase inverter.

The semiconductor modules are mounted on a forced air-cooled or water cooled heat sink. The switching devices interface with a capacitor bank via a low inductance laminated bus. The gate drive board provides a simple user interface along with protection features including: overvoltage, overcurrent, undervoltage lockout, overtemperature, shoot-through, and short circuit protection.

Depending on application characteristics, the SixPac™ is suitable for operation with DC bus voltages up to 1000 VDC and switching frequencies above 10 KHz.

Features:

- High performance IGBT inverter bridge
- Integrated gate drive board with fault monitoring and protection
- System status/troubleshooting LEDs to verify or monitor proper operation
- Isolated, low level (50:1), analog feedback of DC bus voltage
- Isolated gate drive power supplies
- Low inductance laminated bus
- Output current measurement and feedback
- Superior short circuit protection and shoot through prevention

Absolute Maximum Ratings, T_j = 25°C unless otherwise specified

General	Symbol		Units
IGBT Junction Temperature	T _j	-40 to +150	°C
Storage Temperature	T _{stg}	-40 to +150	°C
Operating Temperature	T _{op}	-25 to +85	°C
Voltage Applied to DC terminals	V _{cc}	800	Volts
Isolation Voltage, AC 1 minute, 60 Hz sinusoidal	V _{iso}	3500	Volts
Diode Converter			
RMS Voltage Applied to AC Input Terminals	V _L	1000	Volts
Peak Transient Input Voltage	V _{LM}	1600	Volts
IGBT Inverter			
Collector Current (T _c = 25 C)	I _c	1000	Amps
Peak Collector Current (T _j < 150 C)	I _{CM}	2000	Amps
Emitter Current	I _E	1000	Amps
Peak Emitter Current	I _{EM}	1800	Amps
Maximum Collector Dissipation (T _j < 150 C)	P _c	3900	Watts
Gate Drive Board			
Unregulated +24V Power Supply		30	Volts
Regulated +15V Power Supply		18	Volts
PWM Signal Input Voltage		20	Volts
Fault Signal Output Supply Voltage		30	Volts
Fault Signal Output Current		50	mA

IGBT Inverter Electrical Characteristics, T_j = 25 C unless otherwise specified

Characteristics	Symbol	Test Conditions	Min	Typ	Max	Units
Collector Cutoff Current	I _{CES}	V _{CE} =V _{CES} , V _{GE} =0V	-	-	1	mA
Collector-Emitter Saturation Voltage	V _{CE(SAT)}	I _C =1000A, T _j =25 C	-	1.8	2.5	Volts
		I _C =1000A, T _j =125 C	-	2.0	-	Volts
Emitter-Collector Voltage	V _{EC}	I _E =1000A	-	-	3.4	Volts
Inductive Load Switching Times	t _{d(on)}		-	-	300	ηS
	t _r	V _{CC} =600V			200	ηS
	t _{d(off)}	I _C =600A			800	ηS
	t _f	V _{GE} =15V			300	ηS
Diode Reverse Recovery Time	t _{rr}	R _G =1.0Ω	-	-	500	ηS
Diode Reverse Recovery Charge	Q _{rr}		-	50	-	μC
DC Link Capacitance				5500		μF

Gate Drive Board Electrical Characteristics

Characteristics	Min	Typ	Max	Units
Unregulated +24V Power Supply	20	24	30	Volts
Regulated +15V Power Supply	14.4	15	18	Volts
PWM Input On Threshold	12	15		Volts
PWM Input Off Threshold		0	2	Volts
Output Overcurrent Trip	1,200	1,250	1,300	Amps
Overtemperature Trip	See Performance Curves on pages 5 and 6			
Overvoltage Trip	890	900	910	Volts
DC Link Voltage Feedback		See Figure Below		Volts
Heatsink Temperature Feedback		See Figure Below		Volts
Output Current Feedback		See Figure Below		Volts

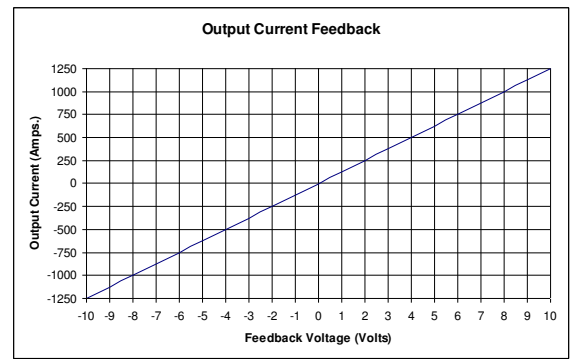
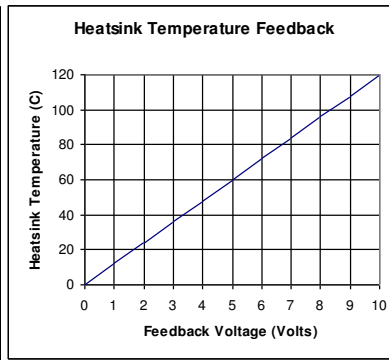
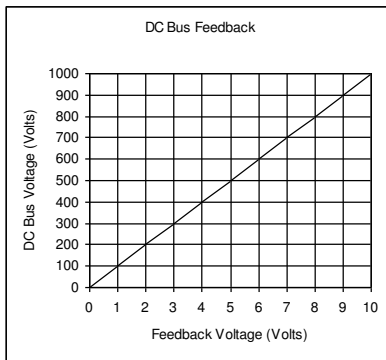
Thermal and Mechanical Characteristics

Characteristics	Symbol	Test Conditions	Min	Typ	Max	Units
IGBT Thermal Resistance, Junc to Case	$R_{\theta(J-C)Q}$	Per IGBT 1/2 module	-	-	.021	°C/W
FWD Thermal Resistance, Junc to Case	$R_{\theta(J-C)D}$	Per FWD 1/2 module			.034	°C/W
Contact Thermal Resistance	$R_{\theta(C-S)}$	Per 1/2 module	-	.016		°C/W
Heatsink Thermal Resistance (Forced Air Cooled)	$R_{\theta(F-A)}$	1500 LFM		.028		°C/W
Heatsink Thermal Resistance (Liquid Cooled)	$R_{\theta(L-C)}$	1.0 GPM		.01		°C/W
Mounting Torque, AC Terminals				75	90	In-lb
Mounting Torque, DC Terminals				130	150	In-lb
Mounting Torque, Mounting plate				130	150	In-lb
Weight				TBD		lb

Input Connector Interface

Pin ⁵	Signal Name	Description
1	Shield	Connected to circuit ground
2	Lo Side Switch	0 – 15V signal controlling the duty cycle of Lo Side Switch IGBT
3	Phase Error ¹	Open collector output, external pull-up resistor required LOW = No Error; Floating = Phase A overcurrent or short circuit
4	Not Used	
5	Overtmp ^{1,5}	Open collector output, external pull-up resistor required LOW = No Error; Floating = heatsink overtemp
6	24 VDC input power ²	20 – 30 VDC input voltage range
7	24 VDC input power ²	20 – 30 VDC input voltage range
8	15 VDC input power ²	14.4 – 18 VDC input voltage range
9	15 VDC input power ²	14.4 – 18 VDC input voltage range
10	GND ³	Ground reference for 15 and 24 VDC inputs
11	GND ³	Ground reference for 15 and 24 VDC inputs
12	Heatsink Temperature	Analog voltage representation of heatsink temperature
13	GND ³	Ground reference for analog signals
14	I _{OUT}	Analog voltage representation of output current

NOTES:

1. Open collectors can be pulled up to 30VDC Max and sink 50mA continuous.
2. **DO NOT** connect a 15VDC and 24VDC source to the unit at the same time. Use one or the other.
3. GND signals to be used for analog feedback signals, i.e. twisted pair with I_{OUT} Phase A.
4. The error signal on pin 5 is the ORed output of the OverVoltage, OverTemp and UVLO fault signals. An LED will illuminate on the board to differentiate specific faults.
5. The gate drive board can be configured with a 16 pin connector, Consult APS engineering for more details.

Gate Drive Board Interface Connector

Description	Symbol	Type	Manufacturer
Gate Drive Board Interface Header	J1	0.100" x 0.100" latching header, 26 pin	3M# 3429-6002 or equivalent
Recommended Mating Socket	-	0.100" x 0.100" IDC socket, 26 pin	3M# 3399-7600 or equivalent
Recommended Strain Relief	-	Plastic strain relief	3M# 3448-3026 or equivalent

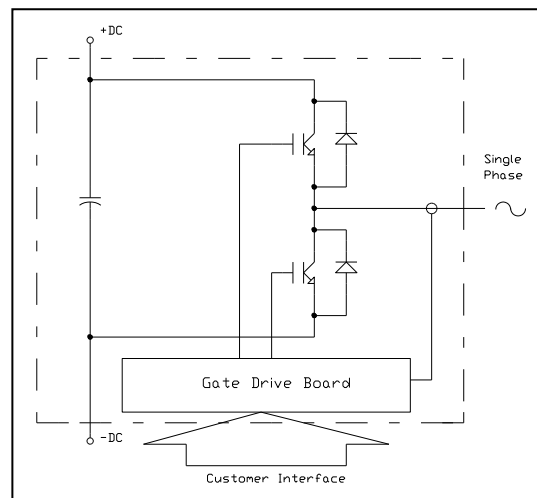
Schematic

Performance Curves Water Cooling

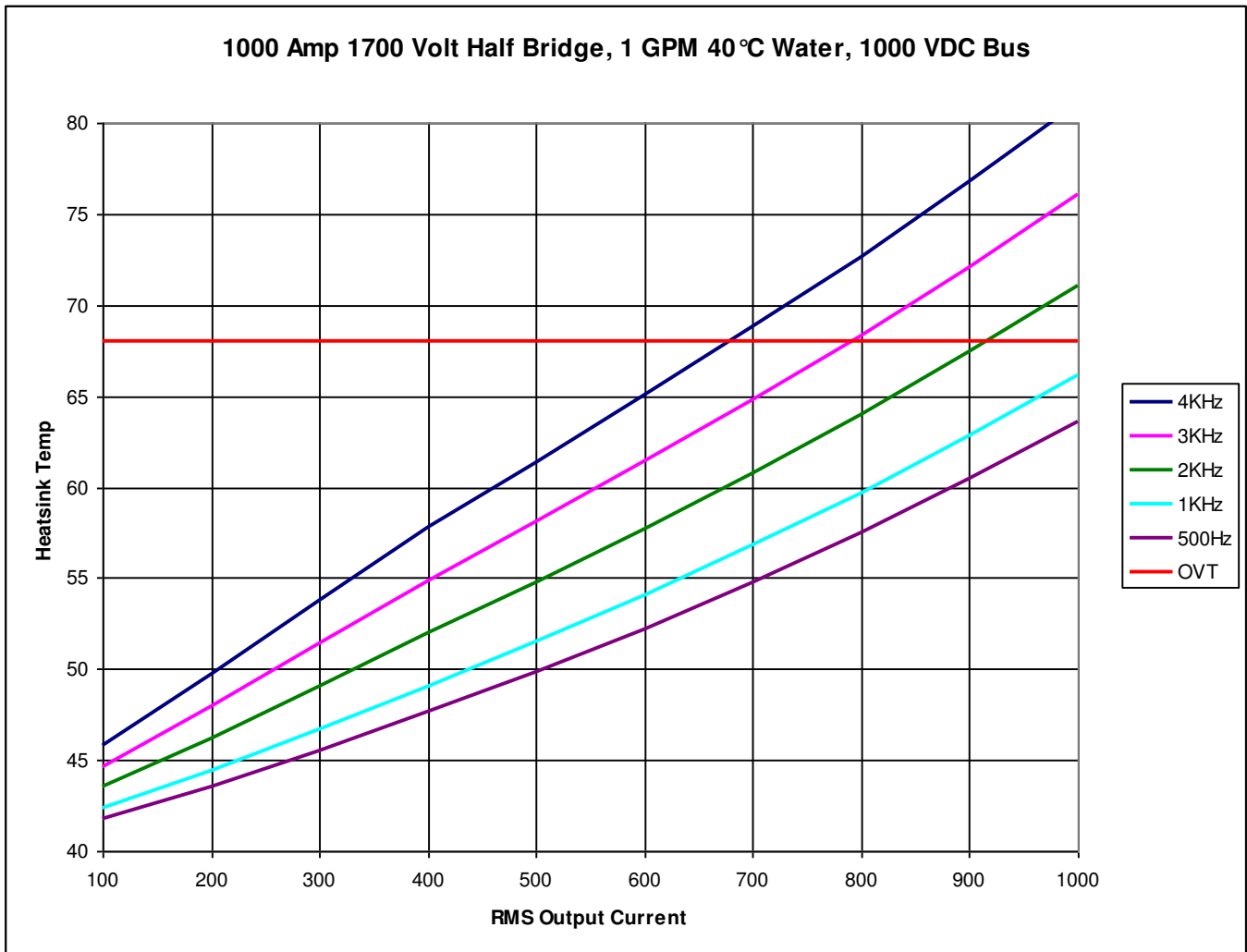

Condition	Symbol	Value	Units
Ambient Temperature	T_A	40	°C
DC Bus Voltage	V_{CC}	1000	Volts
Load Power Factor	$\cos \phi$	0.8	
IGBT Saturation Voltage	$V_{CE(SAT)}$	Typical @ $T_J = 125^\circ\text{C}$	Volts
IGBT Switching Loss	E_{SW}	Typical @ $T_J = 125^\circ\text{C}$	mJ
Water Flow (at 40°C)	-	1.0	GPM
Switching Conditions	3-phase PWM, 60Hz sinusoidal output		

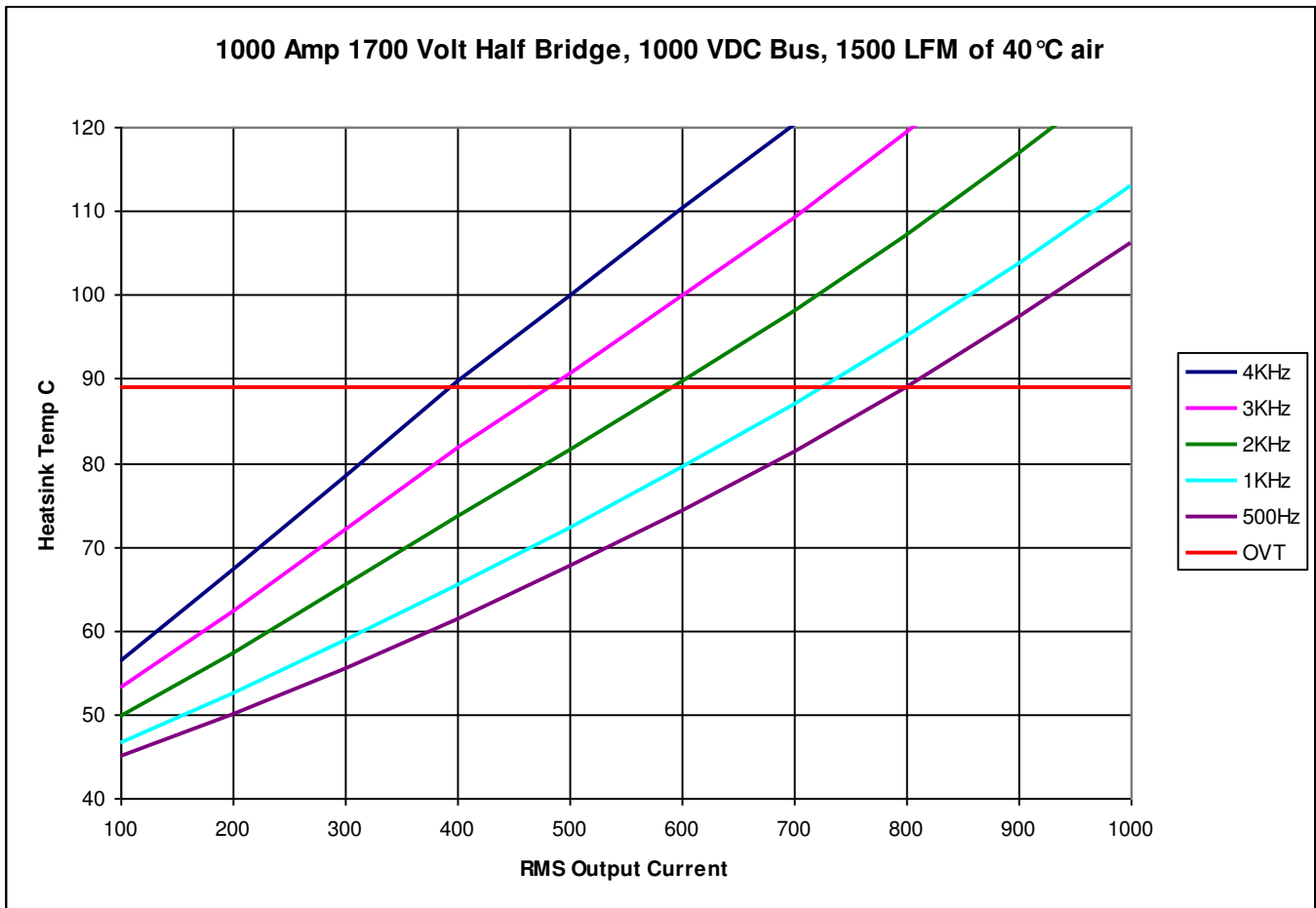
Performance Curves Forced Air Cooling

Condition	Symbol	Value	Units
Ambient Temperature	T_A	40	°C
DC Bus Voltage	V_{CC}	1000	Volts
Load Power Factor	$\cos \phi$	0.8	
IGBT Saturation Voltage	$V_{CE(SAT)}$	Typical @ $T_J = 125^\circ\text{C}$	Volts
IGBT Switching Loss	E_{SW}	Typical @ $T_J = 125^\circ\text{C}$	mJ
Forced Air Flow	-	1500	LFM
Switching Conditions	3-phase PWM, 60Hz sinusoidal output		

Options for the IAP1000D170H-XX and IAPL1000D170-XX

Option	Option Number								
	01	02	03	04	05	06	07	08	09
Blower	X		X		X		X		X
Half-Control SCR Converter		X	X						
Full Control SCR Converter				X	X				
Diode Converter						X	X		
Dual Inverter								X	X

Mechanical Information

Forced Air Cooled Version

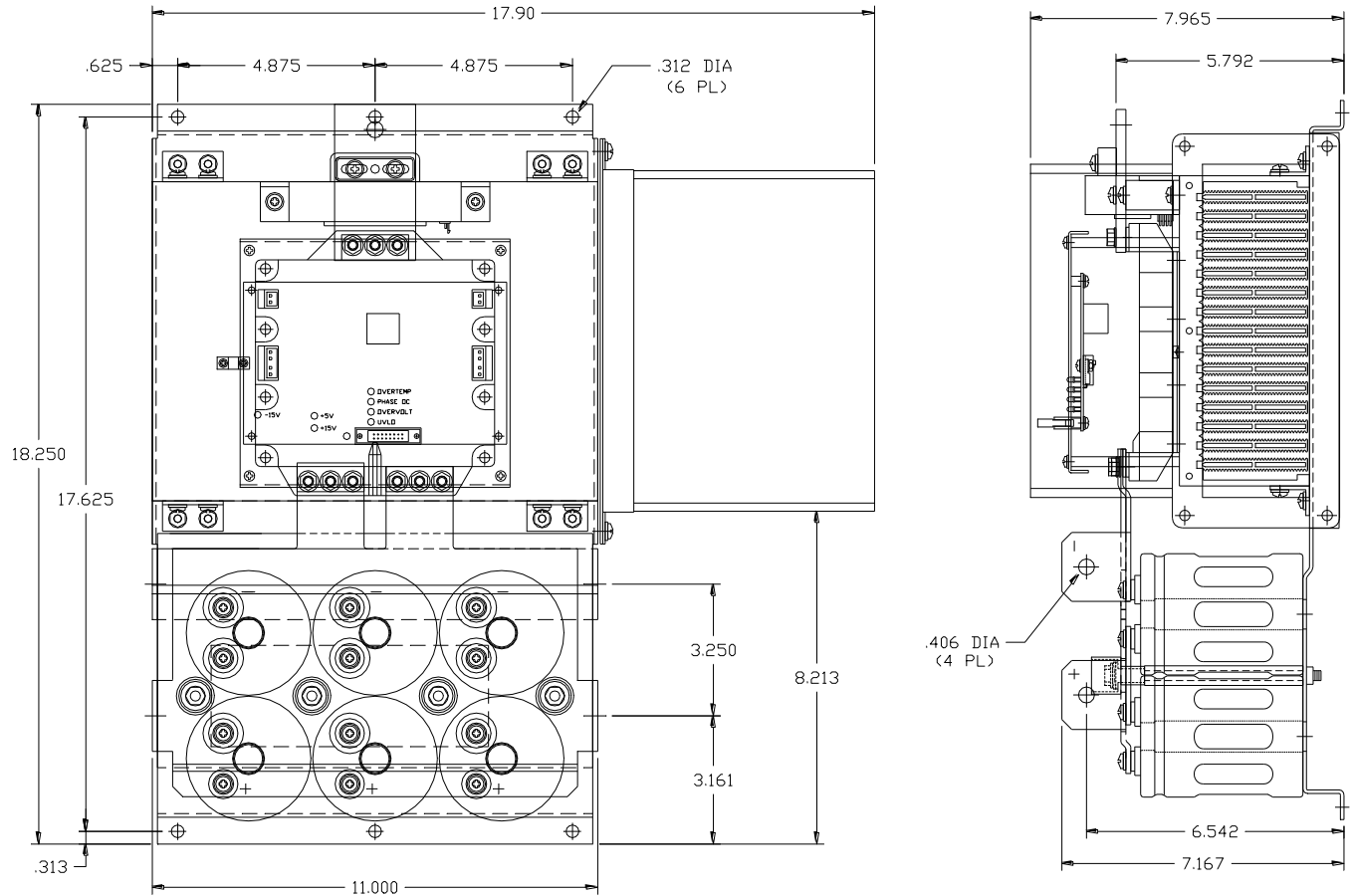

Liquid Cooled Version

