

**IAP400B060X3H SixPac™
Three Phase Inverter Power Stage**

Description:

The SixPac™ from Applied Power Systems is a configurable IGBT based power stage that is configured as a three-phase bridge inverter for motor control, power supply, UPS or other power conversion applications. The IAP400BX3H consists of three 200A full bridges to produce the three-phase inverter.

The IGBTs for the power assembly are mounted on a forced air-cooled or water cooled heat sink. The switching devices interface with a capacitor bank via a low inductance laminated bus. The gate drive board provides a simple user interface along with protection features including: overvoltage, overcurrent, undervoltage lockout, overtemperature, and short circuit protection.

Depending on application characteristics, the SixPac™ is suitable for operation with DC bus voltages up to 400 VDC and switching frequencies above 20 KHz.

Features:

- High performance IGBT inverter bridge
- Integrated gate drive board with fault monitoring and protection
- System status / troubleshooting LEDs to verify or monitor proper operation
- Isolated, low level (50:1), analog feedback of DC bus voltage
- Isolated gate drive power supplies
- Low inductance laminated bus
- Output current measurement and feedback
- Superior short circuit protection and shoot through prevention

Schematic:

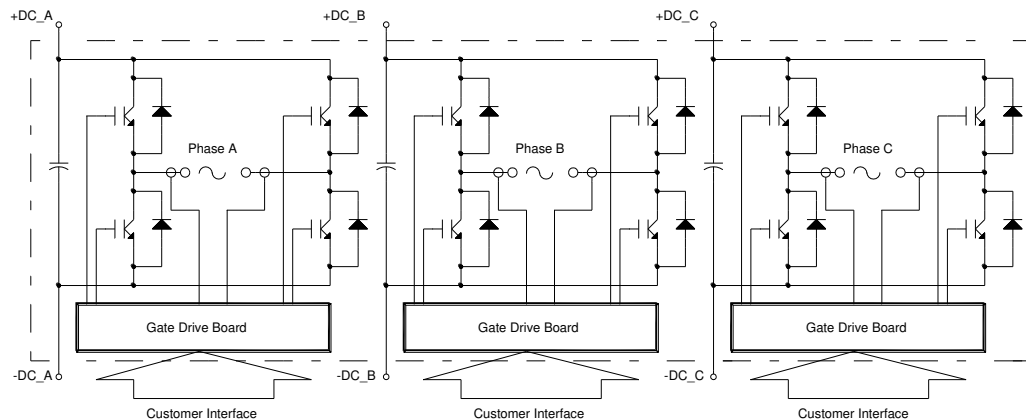

The following parameters are per phase

Absolute Maximum Ratings, $T_j = 25^\circ\text{C}$ unless otherwise specified

General	Symbol		Units
IGBT Junction Temperature	T_j	-40 to +150	$^\circ\text{C}$
Storage Temperature	T_{stg}	-40 to +150	$^\circ\text{C}$
Operating Temperature	T_{op}	-25 to +85	$^\circ\text{C}$
Voltage Applied to DC terminals	V_{cc}	400	Volts
Isolation Voltage, AC 1 minute, 60 Hz sinusoidal	V_{iso}	2500	Volts
IGBT Inverter			
Collector Current ($T_c = 25\text{ C}$)	I_c	400	Amps
Peak Collector Current ($T_j < 150\text{ C}$)	I_{CM}	800	Amps
Emitter Current	I_E	400	Amps
Peak Emitter Current	I_{EM}	800	Amps
Maximum Collector Dissipation ($T_j < 150\text{ C}$)	P_c	960	Watts
Gate Drive Board			
Unregulated +24V Power Supply		30	Volts
Regulated +15V Power Supply		18	Volts
PWM Signal Input Voltage		20	Volts
Fault Signal Output Supply Voltage		30	Volts
Fault Signal Output Current		50	mA

IGBT Inverter Electrical Characteristics, $T_j = 25\text{ C}$ unless otherwise specified

Characteristics	Symbol	Test Conditions	Min	Typ	Max	Units
Collector Cutoff Current	I_{CES}	$V_{\text{CE}}=V_{\text{CES}}, V_{\text{GE}}=0\text{V}$	-	-	1	mA
Collector-Emitter Saturation Voltage	$V_{\text{CE(SAT)}}$	$I_c=400\text{A}, T_j=25\text{ C}$	-	2.0	2.7	Volts
		$I_c=400\text{A}, T_j=125\text{ C}$	-	1.95	-	Volts
Emitter-Collector Voltage	V_{EC}	$I_E=400\text{A}$	-	-	2.6	Volts
Inductive Load Switching Times	$t_{\text{d(on)}}$		-	-	400	ηS
	t_r	$V_{\text{CC}}=300\text{V}$			200	ηS
	$t_{\text{d(off)}}$	$I_c=400\text{A}$			700	ηS
	t_f	$V_{\text{GE}}=15\text{V}$			150	nS
Diode Reverse Recovery Time	t_{rr}	$R_G=4.3\Omega$	-	-	200	nS
Diode Reverse Recovery Charge	Q_{rr}		-	7.7	-	μC
DC Link Capacitance				6600		μF

Gate Drive Board Electrical Characteristics

Characteristics	Min	Typ	Max	Units
Unregulated +24V Power Supply	20	24	30	Volts
Regulated +15V Power Supply	14.4	15	18	Volts
PWM Input On Threshold	12	15		Volts
PWM Input Off Threshold		0	2	Volts
Output Overcurrent Trip		300		Amps
Overtemperature Trip	78	80	82	°C
Overvoltage Trip	435	450	465	Volts
DC Link Voltage Feedback		See Figure Below		Volts
Heatsink Temperature Feedback		See Figure Below		Volts
Output Current Feedback		See Figure Below		Volts

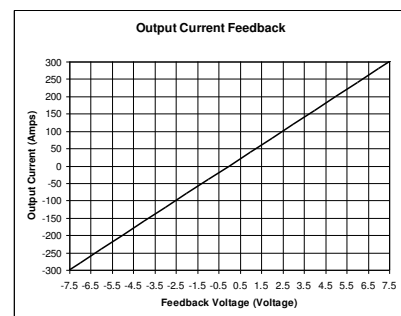
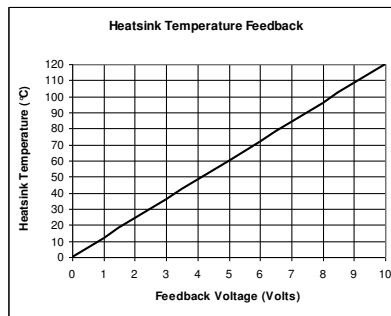
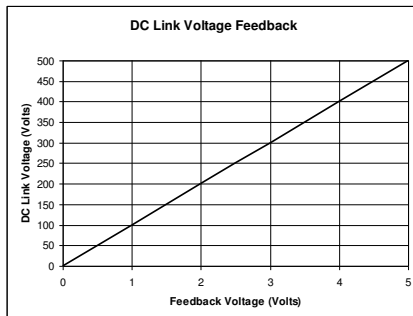
Thermal and Mechanical Characteristics

Characteristics	Symbol	Test Conditions	Min	Typ	Max	Units
IGBT Thermal Resistance, Junc to Case	$R_{\Theta(j-c)Q}$	Per IGBT 1/2 module	-	-	.13	°C/W
FWD Thermal Resistance, Junc to Case	$R_{\Theta(j-c)D}$	Per FWD 1/2 module			.18	°C/W
Contact Thermal Resistance	$R_{\Theta(c-f)}$		-	.045		°C/W
Heatsink Thermal Resistance	$R_{\Theta(f-a)}$	2500 LFM		.028		°C/W
Mounting Torque, AC Terminals				75	90	In-lb
Mounting Torque, DC Terminals				130	150	In-lb
Mounting Torque, Mounting plate				130	150	In-lb
Weight					16	lb

Performance Curves

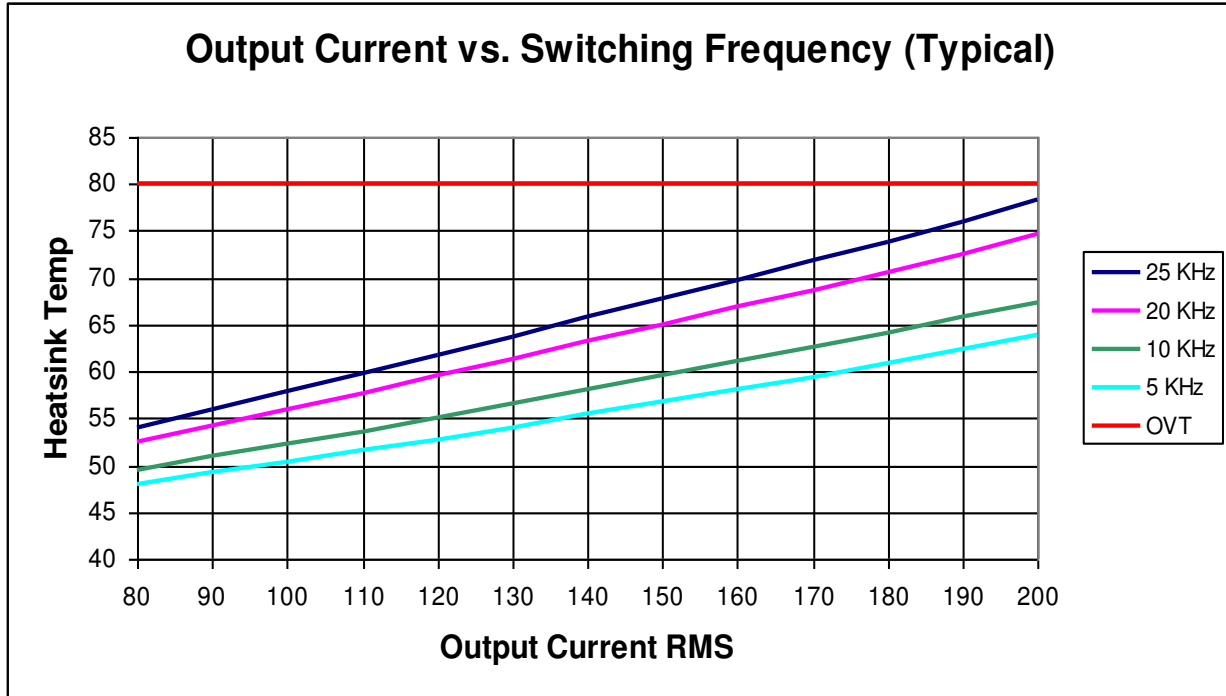

Condition	Symbol	Value	Units
Ambient Temperature	T_A	40	°C
DC Bus Voltage	V_{CC}	300	Volts
Load Power Factor	$\cos \phi$	0.8	
IGBT Saturation Voltage	$V_{CE(SAT)}$	Typical @ $T_J = 125^\circ\text{C}$	Volts
IGBT Switching Loss	E_{SW}	Typical @ $T_J = 125^\circ\text{C}$	mJ
Airflow	-	2500	LFM

Options for the BAP300T120-XX

Option	Option Number								
	01	02	03	04	05	06	07	08	09
Blower	X		X		X		X		X
Half-Control SCR Converter		X	X						
Full Control SCR Converter				X	X				
Diode Converter						X	X		
Dual Inverter								X	X

Interface

Pin	Signal Name	Description
1	Shield	Connected to circuit ground
2	Lo Side Switch (PWM-)	0 – 15V signal controlling the duty cycle of Lo Side Switch IGBT
3	Phase Error ¹	Open collector output, external pull-up resistor required LOW = No Error; Floating = Phase A overcurrent or short circuit
4	High Side Switch (PWM+)	0 – 15V signal controlling the duty cycle of High Side Switch IGBT
5	Overtemp ^{1, 4}	Open collector output, external pull-up resistor required LOW = No Error; Floating = heatsink overtemp
6	24 VDC input power ²	20 – 30 VDC input voltage range
7	24 VDC input power ²	20 – 30 VDC input voltage range
8	15 VDC input power ²	14.4 – 18 VDC input voltage range
9	15 VDC input power ²	14.4 – 18 VDC input voltage range
10	GND	Ground reference for 15 and 24 VDC inputs
11	GND	Ground reference for 15 and 24 VDC inputs
12	Heatsink Temperature ⁵	Analog voltage representation of heatsink temperature
13	GND ³	Ground reference for analog signals
14	I _{OUT}	Analog voltage representation of output current
15	GND ³	Ground reference for 15 and 24 VDC inputs
16	DC Link Voltage	Analog representation of DC Link voltage; 0V represents 0V on the DC Link, 9V represents 900V on DC Link

NOTES:

- Open collectors can be pulled up to 30VDC Max and sink 50mA continuous.
- DO NOT** connect a 15VDC and 24VDC source to the unit at the same time. Use one or the other.
- GND signals to be used for analog feedback signals, i.e. twisted pair with I_{OUT} Phase A.
- The error signal on pin 5 is the ORed output of the OverVoltage, OverTemp and UVLO fault signals. An LED will illuminate on the board to differentiate specific faults.
- The gate drive board can be configured with a 14 pin connector, providing **either** heatsink temperature or DC Link Voltage at pin 12.

Gate Drive Board Interface Connector

Description	Symbol	Type	Manufacturer
Gate Drive Board Interface Header	J1	0.100" x 0.100" latching header, 26 pin	3M# 3429-6002 or equivalent
Recommended Mating Socket	-	0.100" x 0.100" IDC socket, 26 pin	3M# 3399-7600 or equivalent
Recommended Strain Relief	-	Plastic strain relief	3M# 3448-3026 or equivalent

Mechanical Information

