



FEATURES INCLUDE

- Multi-Function Power Assembly
- Compact Size – 9" H X 17.60" W X 11.00" D
- DC Bus Voltages to 850VDC
- Snubber-less operation to 650VDC
- Switching frequencies to over 20kHz
- Protective circuitry with fail-safe opto-isolated fault annunciation, including:
 - Over current
 - Over voltage
 - Over Temperature
 - Short circuit
 - P.S. undervoltage
- Opto-isolated or fiber-optic gate drive and fault signal output for electrical isolation and noise immunity
- Integrated cooling with temperature sensors and feedback
- Many options

Configurable Power

The SixPac™ is a flexible, highly integrated IGBT based power assembly with a wide range of applications. These include inverters for motor controls, switch mode power supplies (SMPS), UPS, welders, etc. The SixPac™ can be operated at frequencies to over 20kHz. The SixPac™ can be configured as a full bridge or three-phase bridge inverter mounted on an air-cooled or liquid-cooled heat sink. Configurations include options for (full, half or no control) converter input circuitry, inverter output circuitry, cooling and a wide variety of drivers and safety features for the converter front end and IGBT inverter output stage.

The SixPac™ provides built in protection features including: over voltage, under voltage lockout, over current, over temperature, short circuit and optional airflow or liquid flow indicators.

Flexibility is a key feature of the SixPac™. Options include: a choice of converter front ends, rectifier, half or full SCR control, with or without SCR gate firing boards and soft-start circuitry. A choice of cooling methods, forced air or liquid is also available. Customer provided PWM is optically coupled or a fiber optic link can be provided to the IGBT interface. Current feedback is provided by Hall effect transducers.

To operate at high switching frequencies, the SixPac™ utilizes a low inductance laminated bus structure, optically isolated or fiber optically coupled gate drive interfaces, isolated gate power supplies and a DC-link capacitor bank.

The SixPac™ is rated to maximum input voltages up to 850 VDC, switching frequencies to over 20kHz, includes many safety features to protect the IGBTs and output circuitry and can be configured to meet your application.

Schematic:

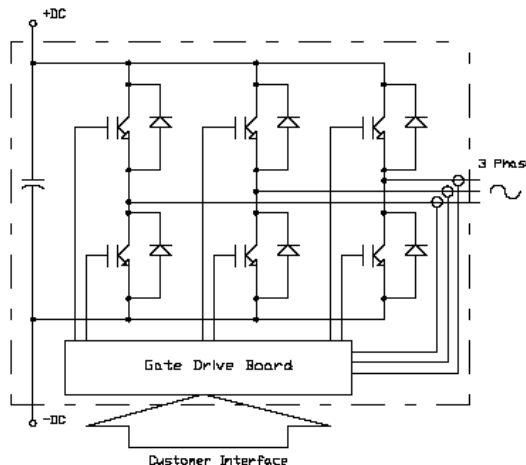

SixPac™ IAP200T120

Absolute Maximum Ratings – T _J =25°C unless otherwise specified			
General	Symbol	Value	Units
IGBT Junction Temperature	T _J	-40 to +150	°C
Storage Temperature	T _{STG}	-40 to +125	°C
Voltage applied to DC terminals	V _{CC}	850	Volts
Isolation voltage, AC 1 minute, 60Hz sinusoidal	V _{ISO}	2500	Volts
IGBT Inverter			
Collector Current (T _C =25°C)	I _C	200	Amperes
Peak Collector Current (T _J <150°C)	I _{CM}	400	Amperes
Emitter Current	I _E	200	Amperes
Peak Emitter Current	I _{EM}	400	Amperes
Maximum Collector Dissipation (T _J <150°C)	P _{CD}	890	Watts
Gate Drive Board			
Unregulated +24V Power Supply		30	Volts
Regulated +15V Power Supply		18	Volts
PWM Signal Input Voltage		20	Volts
Fault Output Supply Voltage		30	Volts
Fault Output Current		50	mA

IGBT Inverter Electrical Characteristics, T_J=25°C unless otherwise specified

Parameter	Symbol	Test Conditions	Min	Typ	Max	Units
Collector Cutoff Current	I _{CES}	V _{CE} =V _{CES} , V _{GE} =0V	-	-	1	mA
Collector-Emitter Saturation Voltage	V _{CE(sat)}	I _C =200A, T _J =25°C	-	1.8	2.4	Volts
		I _C =200A, T _J =125°C	-	1.9	-	Volts
Emitter-Collector Voltage	V _{EC}	I _E =200A	-	-	3.2	Volts
Inductive Load Switching Times	t _{d(on)}	V _{CC} =600V I _C =200A V _{GE} =15V R _G =1.6Ω	-	-	300	ns
	t _r		-	-	80	ns
	t _{d(off)}		-	-	500	ns
	t _r		-	-	300	ns
Diode Reverse Recovery Time	T _{rr}		-	-	200	ns
Diode Reverse Recovery Charge	Q _{rr}		-	12.2	-	μC
DC Link Capacitance			-	4950	-	μF

Thermal and Mechanical Parameters

Parameter	Symbol	Test Conditions	Min	Typ	Max	Units
IGBT Thermal Resistance, Junction to Case	R _{Θ(j-c)}	Per IGBT ½ module	-	0.08	0.15	°C/W
FWD Thermal Resistance, Junction to Case	R _{Θ(j-c)}	Per FWD ½ module	-	-	0.18	°C/W
Heatsink Thermal Resistance	R _{Θ(s-a)}	1500 LFM airflow	-	.045	-	°C/W
Mounting Torque, AC terminals			-	75	90	In-lb
Mounting Torque, DC terminals			-	130	150	In-lb
Mounting Torque, case mounting			-	130	150	In-lb
Weight			-	21	-	lb

Gate Drive Board Electrical Characteristics

Parameter	Min	Typ	Max	Units
Unregulated +24V Power Supply	20	24	30	Volts
Regulated +15V Power Supply	14.4	15	18	Volts
PWM Input On Threshold	12	15	-	Volts
PWM Input Off Threshold	-	0	2	Volts
Output Overcurrent Trip	-	300	-	Amperes
Overtemperature Trip	94	96	98	°C
Overvoltage Trip	-	920	-	Volts
DC Link Voltage Feedback	See Figure Below			Volts
Heatsink Temperature Feedback	See Figure Below			Volts
Output Current Feedback	See Figure Below			Volts

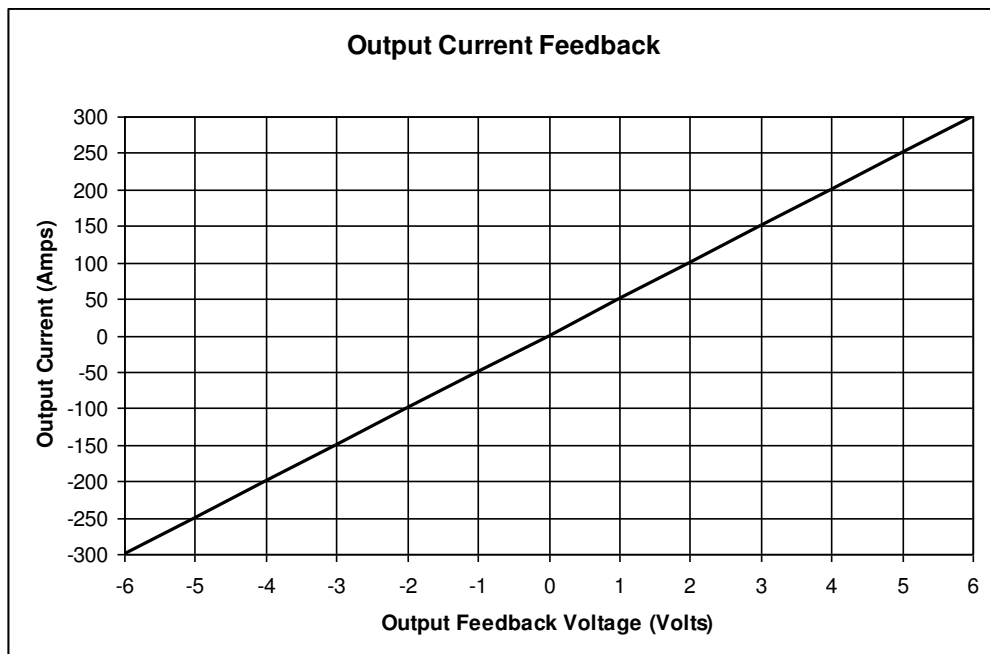
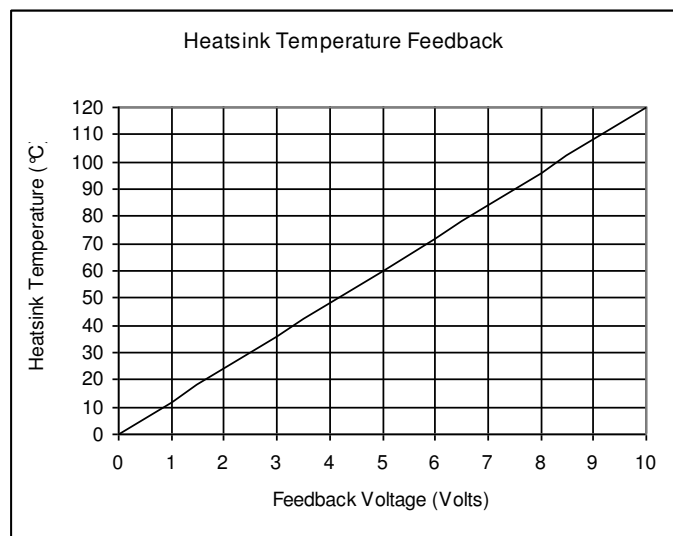
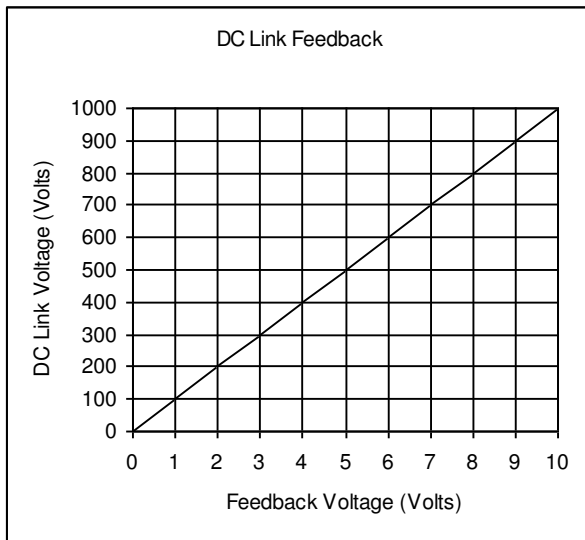

Performance Curves

Effective Output Current vs. Carrier Frequency (Typical)

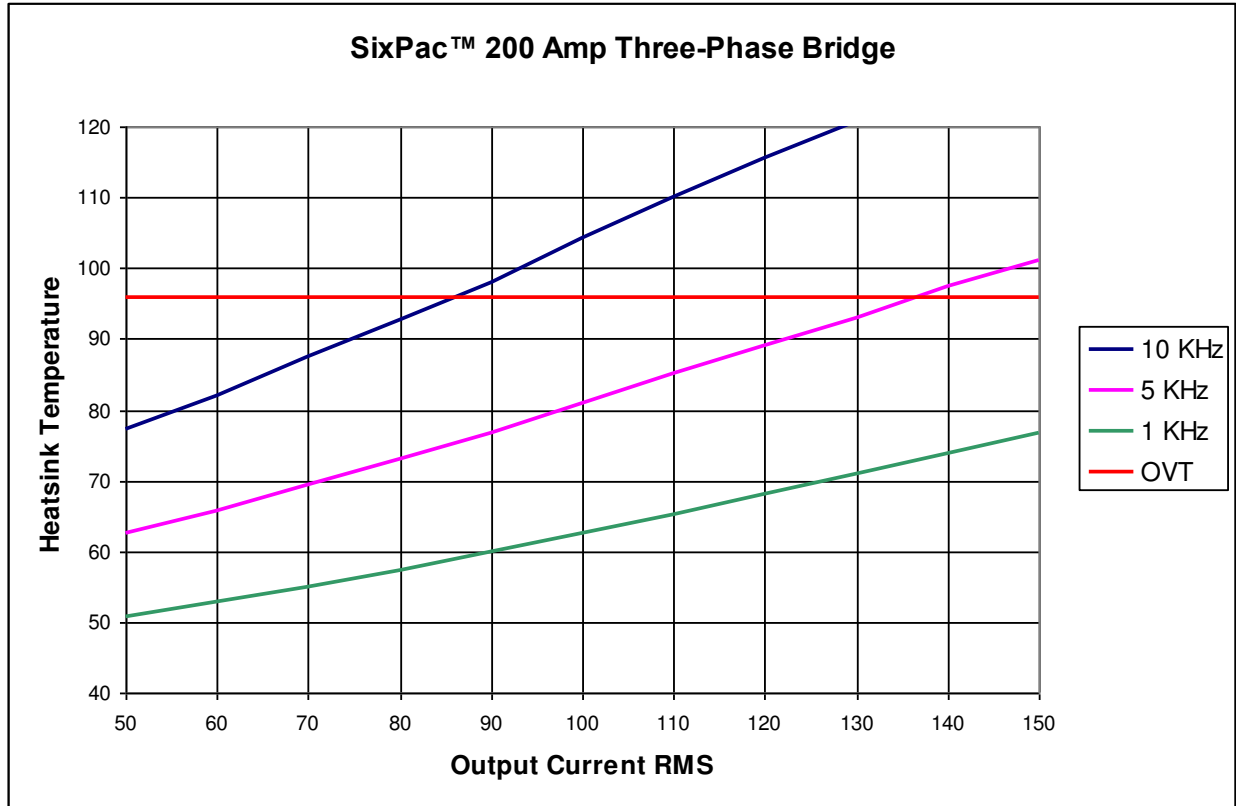

Conditions	Symbol	Value	Units
Ambient Temperature	T_A	40	°C
DC Bus Voltage	V_{CC}	600	Volts
Load Power Factor	$\text{COS } \phi$	0.8	
IGBT Saturation Voltage	$V_{CE(\text{sat})}$	Typical @ $T_J=125^\circ\text{C}$	Volts
IGBT Switching Loss	E_{SW}	Typical @ $T_J=125^\circ\text{C}$	mJ
Airflow	-	1500	LFM
Switching Conditions	Single phase PWM, 60Hz sinusoidal output		

Options for the BAP300T120-XX

Option	Option Number								
	01	02	03	04	05	06	07	08	09
Blower	X		X		X		X		X
Half-Control SCR Converter		X	X						
Full Control SCR Converter				X	X				
Diode Converter						X	X		
Dual Inverter								X	X

Interface

Pin #	Signal Name	Description
1	Shield	Connected to circuit ground
2	PWM A-	0-15V signal controlling the duty cycle of A- IGBT
3	Phase A Error ¹	Open collector output, external pull-up resistor required. LOW=No Error; Floating=Phase A overcurrent or short circuit
4	PWM A+	0-15V signal controlling the duty cycle of A+ IGBT
5	PWM B-	0-15V signal controlling the duty cycle of B- IGBT
6	Phase B Error ¹	Open collector output, external pull-up resistor required. LOW=No Error; Floating=Phase A overcurrent or short circuit
7	PWM B+	0-15V signal controlling the duty cycle of B+ IGBT
8	PWM C-	0 – 15V signal controlling the duty cycle of C- IGBT
9	Phase C Error ¹	Open collector output, external pull-up resistor required LOW=No Error; Floating=Phase A overcurrent or short circuit
10	PWM C+	0 – 15V signal controlling the duty cycle of C+ IGBT
11	OverTemp ¹	Open collector output, external pull-up resistor required. LOW=No Error; Floating=Heatsink overtemp
12	Not Connected	
13	DC Link Voltage	Analog voltage representation of DC link voltage
14	24VDC Input Power ²	20-30VDC input voltage range
15	24VDC Input Power ²	20-30VDC input voltage range
16	15VDC Input Power ²	14.4-18VDC input voltage range
17	15VDC Input Power ²	14.4-18VDC input voltage range
18	GND	Ground reference for 15 and 24VDC inputs
19	GND	Ground reference for 15 and 24VDC inputs
20	Heatsink Temperature	Analog voltage representation of heatsink temperature
21	GND ³	Tied to pins 18 and 19
22	I _{OUT} Phase A	Analog voltage representation of phase A output current
23	GND ³	Tied to pins 18 and 19
24	I _{OUT} Phase B	Analog voltage representation of phase B output current
25	GND ³	Tied to pins 18 and 19
26	I _{out} Phase C	Analog representation of phase C output current

NOTES:

1. Open collectors can be pulled up to 30VDC Max and sink 50mA continuous.
2. **DO NOT** connect a 15VDC and 24VDC source to the unit at the same time. Use one or the other.
3. GND signals to be used for analog feedback signals, i.e. twisted pair with I_{OUT} Phase A.

Gate Drive Interface Connector

Description	Symbol	Type	Manufacturer
Gate Drive Interface Header	J1	0.100" x 0.100" latching header, 26 pin	3M #3429-6002 or equivalent
Recommending Mating Socket	-	0.100" x 0.100" IDC socket, 26 pin	3M #3399-7600 or equivalent
Recommended Strain Relief	-	Plastic strain relief	3M #3448-3026 or equivalent

Mechanical Information

