



IAP100T120 FEATURES INCLUDE

- Compact Size – 9.00” H X 11.00” W X 17.56” D
- DC Bus Voltages to 850VDC
- Snubber-less operation to 650VDC
- Switching frequencies to over 20kHz
- Protective circuitry with fail-safe opto-isolated fault annunciation, including:
 - OverCurrent
 - OverVoltage
 - OverTemperature
 - Short circuit
 - P.S. UnderVoltage
- Opto-isolated or fiber-optic gate drive and fault signal output for electrical isolation and noise immunity
- Integrated cooling with temperature sensors and feedback
- Many options

Configurable Power

The SixPac™ is a flexible, highly integrated IGBT based power assembly with a wide range of applications. These include inverters for motor controls, switch mode power supplies (SMPS), UPS, welders, etc. The SixPac™ can be operated at frequencies to over 20kHz. The SixPac™ can be configured as a full bridge or three-phase bridge inverter mounted on an air-cooled or liquid-cooled heat sink. Configurations include options for (full, half or no control) converter input circuitry, inverter output circuitry, cooling and a wide variety of drivers and safety features for the converter front end and IGBT inverter output stage.

To operate at high switching frequencies, the SixPac™ utilizes a low inductance laminated bus structure, optically isolated or fiber optically coupled gate drive interfaces, isolated gate power supplies and a DC-link capacitor bank.

The SixPac™ provides built in protection features including: over voltage, under voltage lockout, over current, over temperature, short circuit and optional airflow or liquid flow indicators.

Flexibility is a key feature of the SixPac™. Options include: a choice of converter front ends, rectifier, half or full SCR control, with or without SCR gate firing boards and soft-start circuitry. A choice of cooling methods, forced air or liquid is also available. Customer provided PWM is optically coupled or a fiber optic link can be provided to the IGBT interface. Current feedback is provided by Hall effect transducers.

The SixPac™ is rated to maximum input voltages up to 800 VDC, switching frequencies to over 20kHz, includes many safety features to protect the IGBTs and output circuitry and can be configured to meet your application.

Schematic:

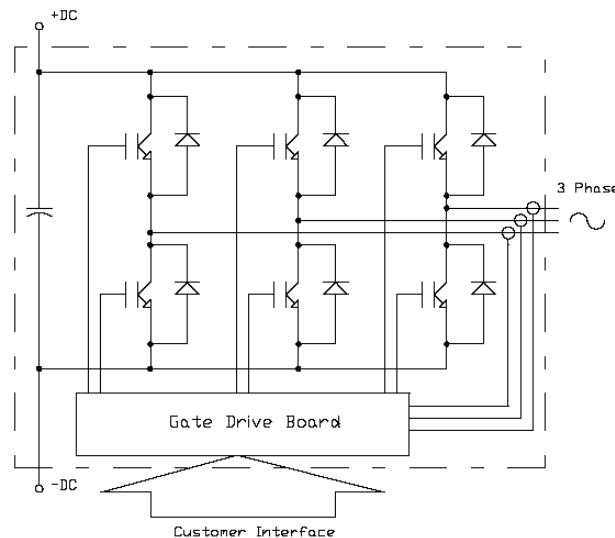

SixPac™ IAP100T120

| Absolute Maximum Ratings – T _J =25°C unless otherwise specified | | | |
|--|------------------|-------------|---------|
| General | Symbol | Value | Units |
| IGBT Junction Temperature | T _J | -40 to +150 | °C |
| Storage Temperature | T _{STG} | -40 to +125 | °C |
| Voltage applied to DC terminals | V _{CC} | 800 | Volts |
| Isolation voltage, AC 1 minute, 60Hz sinusoidal | V _{ISO} | 2500 | Volts |
| IGBT Inverter | | | |
| Collector Current (T _C =25°C) | I _C | 100 | Amperes |
| Peak Collector Current (T _J <150°C) | I _{CM} | 200 | Amperes |
| Emitter Current | I _E | 100 | Amperes |
| Peak Emitter Current | I _{EM} | 200 | Amperes |
| Maximum Collector Dissipation (T _J <150°C) | P _{CD} | 500 | Watts |
| Gate Drive Board | | | |
| Unregulated +24V Power Supply | | 30 | Volts |
| Regulated +15V Power Supply | | 18 | Volts |
| PWM Signal Input Voltage | | 20 | Volts |
| Fault Output Supply Voltage | | 30 | Volts |
| Fault Output Current | | 50 | mA |

IGBT Inverter Electrical Characteristics, T_J=25°C unless otherwise specified

| Parameter | Symbol | Test Conditions | Min | Typ | Max | Units |
|--------------------------------------|----------------------|---|-----|------|-----|-------|
| Collector Cutoff Current | I _{CES} | V _{CE} =V _{CES} , V _{GE} =0V | - | - | 1 | mA |
| Collector-Emitter Saturation Voltage | V _{CE(sat)} | I _C =100A, T _J =25°C | - | 1.8 | 2.4 | Volts |
| | | I _C =100A, T _J =125°C | - | 1.9 | - | Volts |
| Emitter-Collector Voltage | V _{EC} | I _E =100A | - | - | 3.2 | Volts |
| Inductive Load Switching Times | t _{d(on)} | V _{CC} =600V I _C =100A V _{GE} =15V R _G =3.1Ω | - | - | 100 | ns |
| | t _r | | - | - | 50 | ns |
| | t _{d(off)} | | - | - | 400 | ns |
| | t _f | | - | - | 300 | ns |
| Diode Reverse Recovery Time | T _{rr} | | - | - | 150 | ns |
| Diode Reverse Recovery Charge | Q _{rr} | | - | 4.1 | - | μC |
| DC Link Capacitance | | | - | 3300 | - | μF |

Thermal and Mechanical Parameters

| Parameter | Symbol | Test Conditions | Min | Typ | Max | Units |
|---|---------------------|-------------------|-----|------|------|-------|
| IGBT Thermal Resistance, Junction to Case | R _{O(j-c)} | Per IGBT ½ module | - | 0.15 | 0.25 | °C/W |
| FWD Thermal Resistance, Junction to Case | R _{O(j-c)} | Per FWD ½ module | - | - | 0.35 | °C/W |
| Heatsink Thermal Resistance | R _{O(s-a)} | 1500 LFM airflow | - | .045 | - | °C/W |
| Mounting Torque, AC terminals | | | - | 75 | 90 | In-lb |
| Mounting Torque, DC terminals | | | - | 130 | 150 | In-lb |
| Mounting Torque, case mounting | | | - | 130 | 150 | In-lb |
| Weight | | | - | 21 | - | lb |

Gate Drive Board Electrical Characteristics

| Parameter | Min | Typ | Max | Units |
|-------------------------------|------------------|-----|-----|---------|
| Unregulated +24V Power Supply | 20 | 24 | 30 | Volts |
| Regulated +15V Power Supply | 14.4 | 15 | 18 | Volts |
| PWM Input On Threshold | 12 | 15 | - | Volts |
| PWM Input Off Threshold | - | 0 | 2 | Volts |
| Output Overcurrent Trip | - | 150 | - | Amperes |
| Overtemperature Trip | 84 | 86 | 88 | °C |
| Overvoltage Trip | - | 900 | - | Volts |
| DC Link Voltage Feedback | See Figure Below | | | Volts |
| Heatsink Temperature Feedback | See Figure Below | | | Volts |
| Output Current Feedback | See Figure Below | | | Volts |

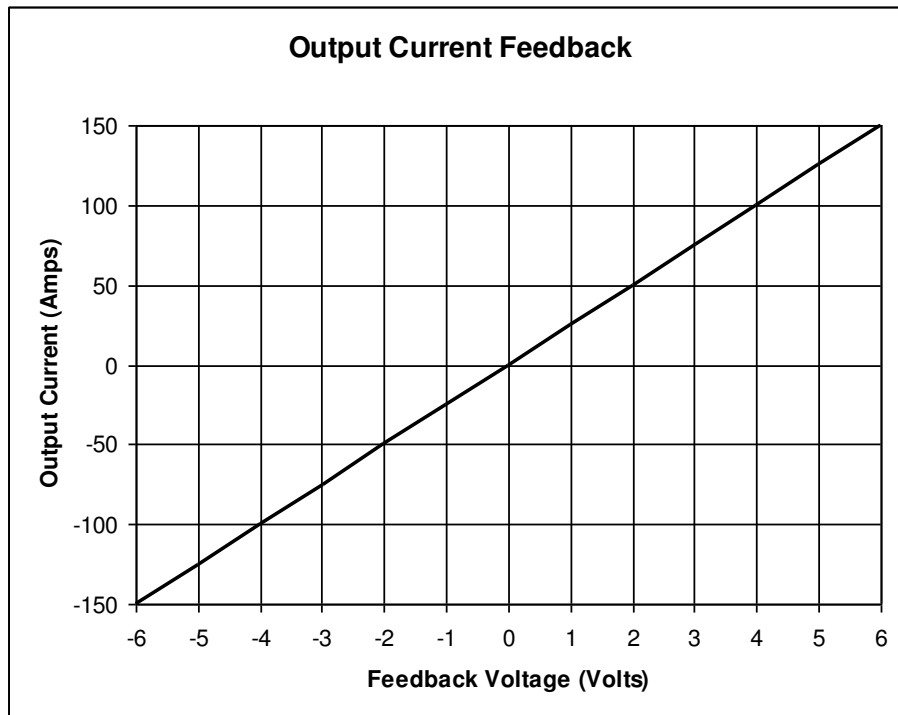
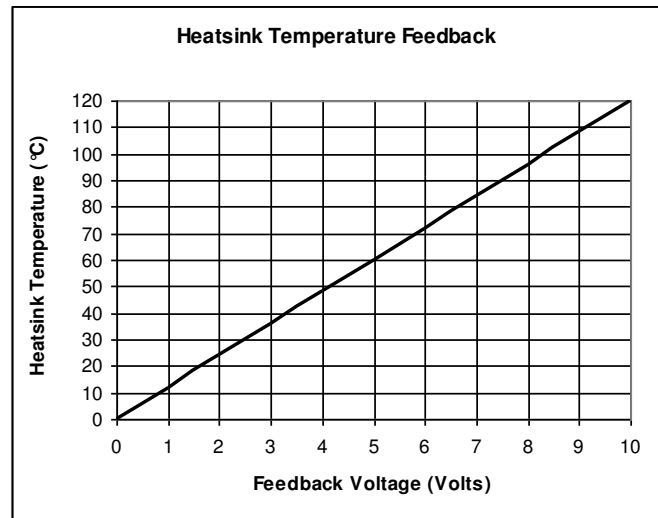
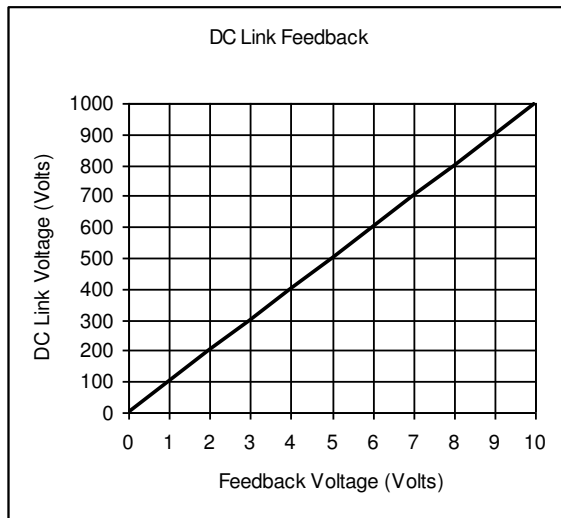

Performance Curves

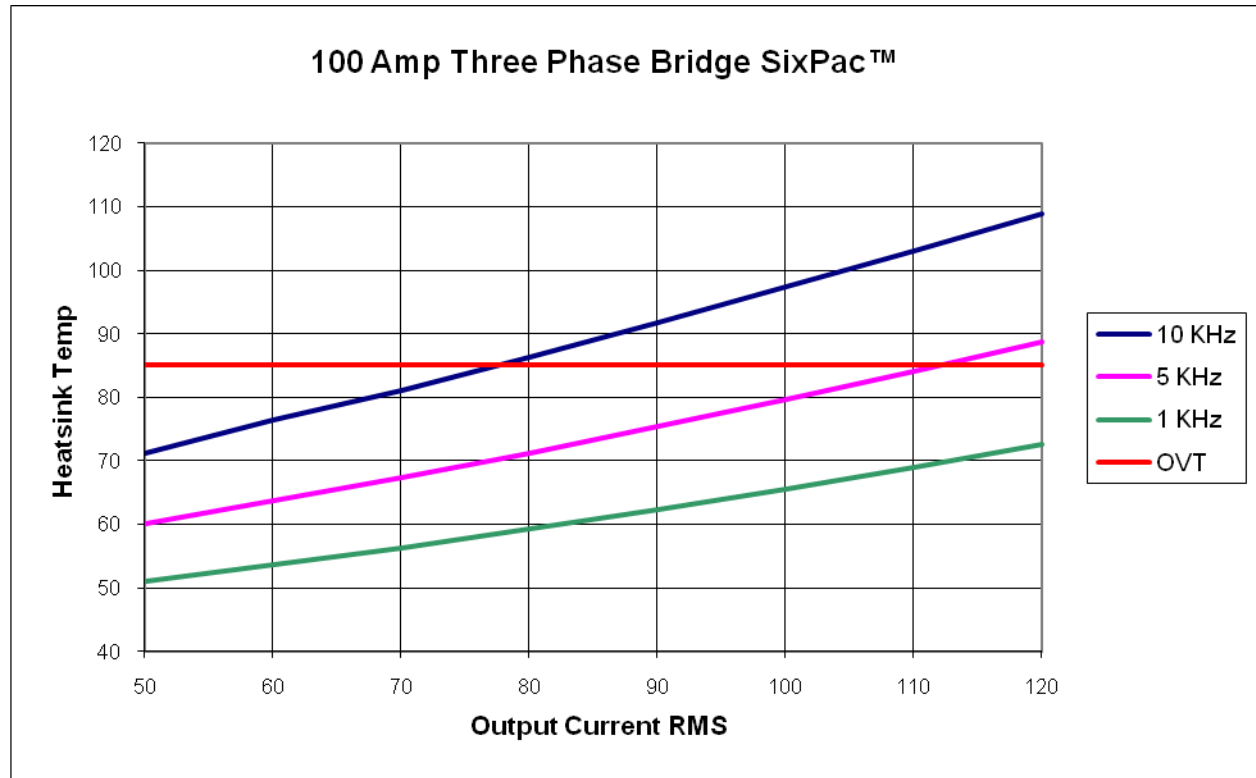

| Conditions | Symbol | Value | Units |
|-------------------------|---|-----------------------------------|-------|
| Ambient Temperature | T_A | 40 | °C |
| DC Bus Voltage | V_{CC} | 600 | Volts |
| Load Power Factor | $\text{COS } \Phi$ | 0.8 | |
| IGBT Saturation Voltage | $V_{CE(\text{sat})}$ | Typical @ $T_J=125^\circ\text{C}$ | Volts |
| IGBT Switching Loss | E_{SW} | Typical @ $T_J=125^\circ\text{C}$ | mJ |
| Airflow | - | 1500 | LFM |
| Switching Conditions | Three-phase PWM, 60Hz sinusoidal output | | |

Options for the BAP300T120-XX

| Option | Option Number | | | | | | | | |
|----------------------------|---------------|----|----|----|----|----|----|----|----|
| | 01 | 02 | 03 | 04 | 05 | 06 | 07 | 08 | 09 |
| Blower | X | | X | | X | | X | | X |
| Half-Control SCR Converter | | X | X | | | | | | |
| Full Control SCR Converter | | | | X | X | | | | |
| Diode Converter | | | | | | X | X | | |
| Dual Inverter | | | | | | | | X | X |

Interface

| Pin # | Signal Name | Description |
|-------|--------------------------------|---|
| 1 | Shield | Connected to circuit ground |
| 2 | PWM A- | 0-15V signal controlling the duty cycle of A- IGBT |
| 3 | Phase A Error ¹ | Open collector output, external pull-up resistor required. LOW=No Error; Floating=Phase A overcurrent or short circuit |
| 4 | PWM A+ | 0-15V signal controlling the duty cycle of A+ IGBT |
| 5 | PWM B- | 0-15V signal controlling the duty cycle of B- IGBT |
| 6 | Phase B Error ¹ | Open collector output, external pull-up resistor required. LOW=No Error; Floating=Phase B overcurrent or short circuit |
| 7 | PWM B+ | 0-15V signal controlling the duty cycle of B+ IGBT |
| 8 | PWM C- | 0-15V signal controlling the duty cycle of C- IGBT |
| 9 | Phase C Error ¹ | Open collector output, external pull-up resistor required. LOW=No Error; Floating=Phase C overcurrent or short circuit |
| 10 | PWM C+ | 0-15V signal controlling the duty cycle of C+ IGBT |
| 11 | OverTemp ¹ | Open collector output, external pull-up resistor required. LOW=No Error; Floating=Heatsink overtemp |
| 12 | Not Connected | 0-15V signal controlling the duty cycle of C+ IGBT |
| 13 | DC Link Voltage | Analog voltage representation of DC link voltage |
| 14 | 24VDC Input Power ² | 20-30VDC input voltage range |
| 15 | 24VDC Input Power ² | 20-30VDC input voltage range |
| 16 | 15VDC Input Power ² | 14.4-18VDC input voltage range |
| 17 | 15VDC Input Power ² | 14.4-18VDC input voltage range |
| 18 | GND | Ground reference for 15 and 24VDC inputs |
| 19 | GND | Ground reference for 15 and 24VDC inputs |
| 20 | Heatsink Temperature | Analog voltage representation of heatsink temperature |
| 21 | GND ³ | Tied to pins 18 and 19 |
| 22 | I _{OUT} Phase A | Analog voltage representation of phase A output current |
| 23 | GND ³ | Tied to pins 18 and 19 |
| 24 | I _{OUT} Phase B | Analog voltage representation of phase B output current |
| 25 | GND ³ | Tied to pins 18 and 19 |
| 26 | I _{out} Phase C | Analog voltage representation of phase C output current |

NOTES:

- Open collectors can be pulled up to 30VDC Max and sink 50mA continuous.
- DO NOT** connect a 15VDC and 24VDC source to the unit at the same time. Use one or the other.
- GND signals to be used for analog feedback signals, i.e. twisted pair with I_{OUT} Phase A.

Gate Drive Interface Connector

| Description | Symbol | Type | Manufacturer |
|-----------------------------|--------|---|-----------------------------|
| Gate Drive Interface Header | J1 | 0.100" x 0.100" latching header, 26 pin | 3M #3429-6002 or equivalent |
| Recommending Mating Socket | - | 0.100" x 0.100" IDC socket, 26 pin | 3M #3399-7600 or equivalent |
| Recommended Strain Relief | - | Plastic strain relief | 3M #3448-3026 or equivalent |

Mechanical Information

