

SMT POWER INDUCTORS

Power Beads - PA131xAHL Series Coupled Inductors

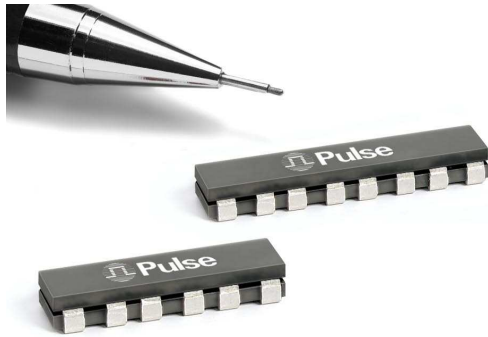
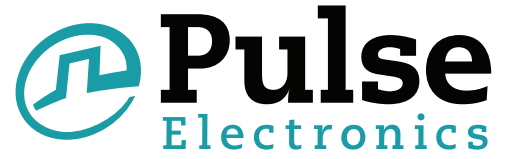

- Gen1.5 Coupled Inductors (PA131xAHL) enables higher efficiency compared to the Gen1.0 Coupled Inductors (PA131xNL) due to lower switching losses in the same package size
- For use only with Volterra chipsets
- Halogen Free and RoHS compliant

Electrical Specifications @ 25°C — Operating Temperature -40°C to +130°C

Pulse Part No.	Number of Coupled Phases	Equivalent ¹ Transient Inductance per Phase (nH)	Rated ² per Phase (A _{dc})	Magnetizing Inductance per Phase ³ nH Min, 0A _{dc}					DCR/Phase ⁴ (mΩ)	
				L1	L2	L3	L4	L5	TYP	MAX
				(1-2)	(3-4)	(5-6)	(7-8)	(9-10)		
PA1312AHL	2	50	40	310	310	–	–	–	0.425	0.5
PA1313AHL	3	50	40	290	400	290	–	–		
PA1314AHL	4	50	40	296	392	392	296	–		

NOTES:

- In a non-coupled multi-phase topology, the power supply sees the same inductance during transient and steady-state conditions. As a result, any attempt to lower the inductance to improve transient response has the negative result of increasing ripple and peak currents throughout the system during steady-state operation. However, in a coupled inductor multi-phase topology, the interaction of magnetic fields from each phase enables an overall reduction in ripple current during steady-state operation and a lower equivalent inductance during transient operation. The equivalent transient inductance per phase, as listed, represents the actual value of inductance that would be required in a non-coupled topology to realize the same transient performance. This value is achieved by core and winding geometry and is not directly measured by Pulse. For more information on the operation of the coupled inductor topology, please contact Volterra.
- The rated current per phase is based on Volterra's testing of the Pulse coupled inductors.
- The magnetizing inductance per phase is the measured inductance (at 0A_{dc}) across each phase when all other phases are open-circuit.
- The nominal value of DCR/phase is for reference only. For production testing, the maximum limit is used.

Mechanical

Schematic

PA1312AHL

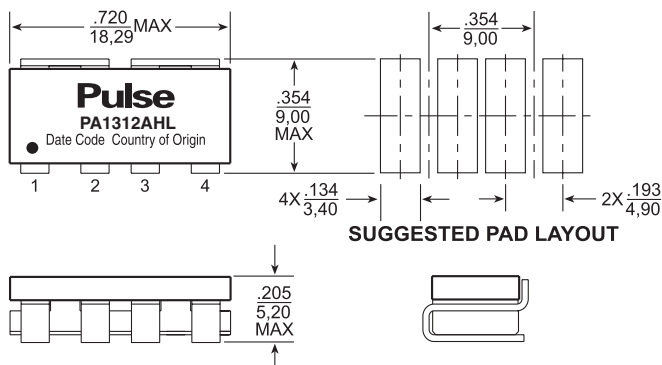

Weight 4.5 grams
 Tape & Reel 650/reel
 Tray 45/tray

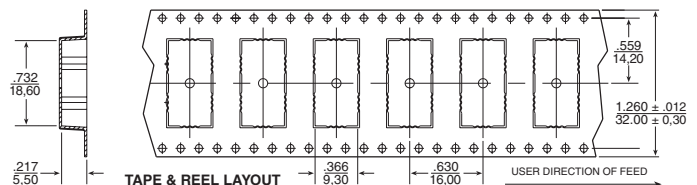
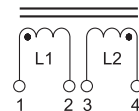

SMT POWER INDUCTORS

Power Beads - PA131xAHL Series Coupled Inductors

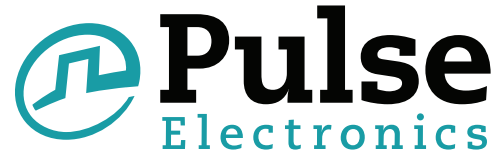

Mechanical

Schematic

PA1313AHL

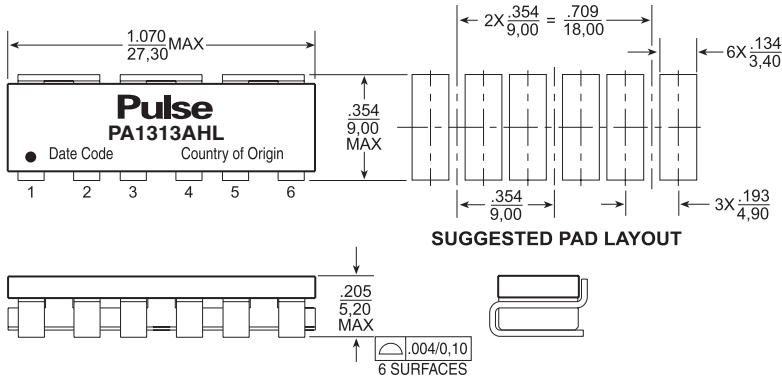

Weight 4.5 grams
 Tape & Reel 650/reel
 Tray 45/tray

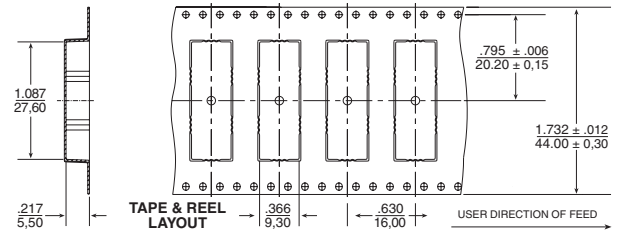
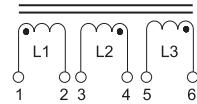

Mechanical

Schematic

PA1314AHL

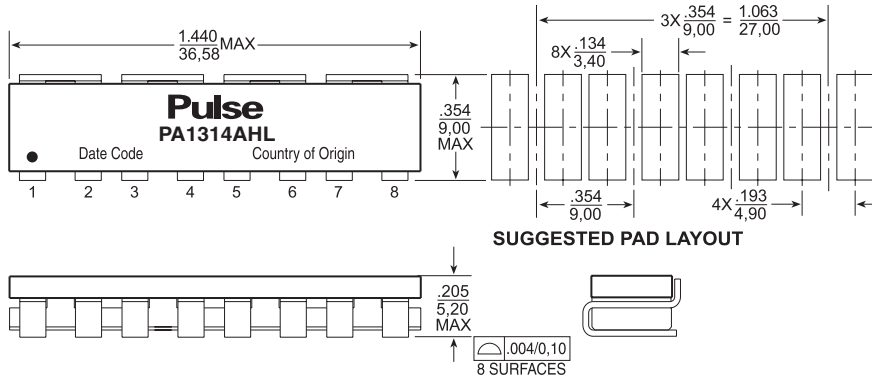

Weight 6.0 grams
 Tape & Reel ... 550/reel
 Tray 30/tray

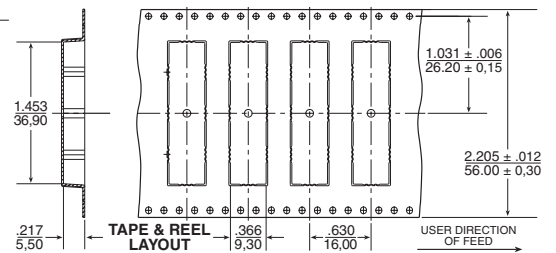
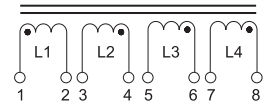

For More Information:

Pulse North American Headquarters
 12220 World Trade Dr.
 San Diego, CA 92128
 U.S.A.

Pulse European Headquarters
 Einsteinstrasse 1
 D-71083 Herrenberg
 Germany

Pulse China Headquarters
 B402, Shenzhen Academy of
 Aerospace Technology Bldg.
 10th Kejinan Rd.
 High-Tech Zone
 Nanshan District
 Shenzhen, PR China 518057

Pulse North China
 Room 1503
 XinYin Building
 No. 888 YiShan Rd.
 Shanghai 200233
 China

Pulse South Asia
 150 Kampong Ampat
 #07-01/02
 KA Centre
 Singapore 368324

Pulse North Asia
 No. 26
 Kao Ching Rd.
 Yang Mei Chen
 Taoyuan Hsien
 Taiwan, R. O. C.
 32667

TEL: 858 674 8100
 FAX: 858 674 8262

TEL: 49 7032 7806 0
 FAX: 49 7032 7806 12

TEL: 86 755 33966678
 FAX: 86 755 33966700

TEL: 86 21 32181071
 FAX: 86 21 32181396

TEL: 65 6287 8998
 FAX: 65 6280 0080

TEL: 886 3 4643715
 FAX: 886 3 4641911

Performance warranty of products offered on this data sheet is limited to the parameters specified. Data is subject to change without notice. Other brand and product names mentioned herein may be trademarks or registered trademarks of their respective owners. Pulse and the Squarewave logo are trademarks of Pulse Electronics Corporation, registered in the U.S. and other countries. © Copyright, 2010. Pulse Electronics Corporation. All rights reserved.