

KBP2005 THRU KBP210

Single Phase 2.0 AMPS. Glass Passivated Bridge Rectifiers

Voltage Range 50 to 1000 Volts Current 2.0 Amperes

FEATURES

- ◆ Ideal for printed circuit board
- ◆ Reliable low cost construction technique results in inexpensive product
- ◆ High temperature soldering guaranteed:
250°C / 10 seconds / 0.375" (9.5mm)
lead length at 5 lbs., (2.3 kg) tension
- ◆ UL Recognized File number: E347215

MECHANICAL DATA

- ◆ Case: Molded plastic
- ◆ Lead: solder plated
- ◆ Polarity: As marked

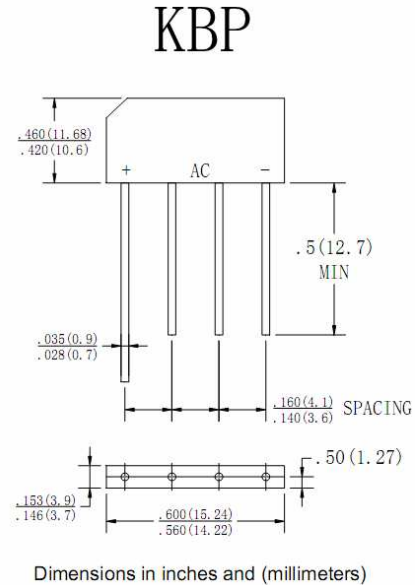

MAXIMUM RATINGS AND ELECTRICAL CHARACTERISTICS

Rating at 25°C ambient temperature unless otherwise specified.

Single phase, half wave, 60 Hz, resistive or inductive load. For capacitive load, derate current by 20%

Type Number		KBP	KBP	KBP	KBP	KBP	KBP	KBP	UNITS
		2005	201	202	204	206	208	210	
Maximum Repetitive Peak Reverse Voltage	VRRM	50	100	200	400	600	800	1000	V
Maximum RMS Voltage	VRMS	35	70	140	280	420	560	700	V
Maximum DC blocking Voltage	VDC	50	100	200	400	600	800	1000	V
Maximum Average Forward Rectified Current @TA = 50°C	I(AV)	2.0							A
Peak Forward Surge Current, 8.3 ms Single Half Sine-wave Superimposed on Rated Load (JEDEC method)	IFSM	60							A
Maximum Instantaneous Forward Voltage @ 3.14A	VF	1.2							V
Maximum DC Reverse Current @ TA=25°C rated DC blocking voltage per leg TA = 125°C	IR	10 500							µA
Typical Thermal Resistance (Note)	RθJA	25							°C/W
	RθJL	8.0							
Operating Temperature Range	TJ	-55 to +150							°C
Storage Temperature Range	TSTG	-55 to +150							°C

NOTE: Thermal Resistance from Junction to Ambient and from Junction to Lead Mounted on P.C.B. with 0.47×0.47"(12×12mm) Copper Pads

KBP2005 THRU KBP210

Single Phase 2.0 AMPS. Glass Passivated Bridge Rectifiers

Voltage Range 50 to 1000 Volts Current 2.0 Amperes

RATING AND CHARACTERISTIC CURVES KBP2005 THRU KBP210

FIG.1-MAXIMUM NONO-REPETITIVE FORWARD SURGE CURRENT PER BRIDGE ELEMNT

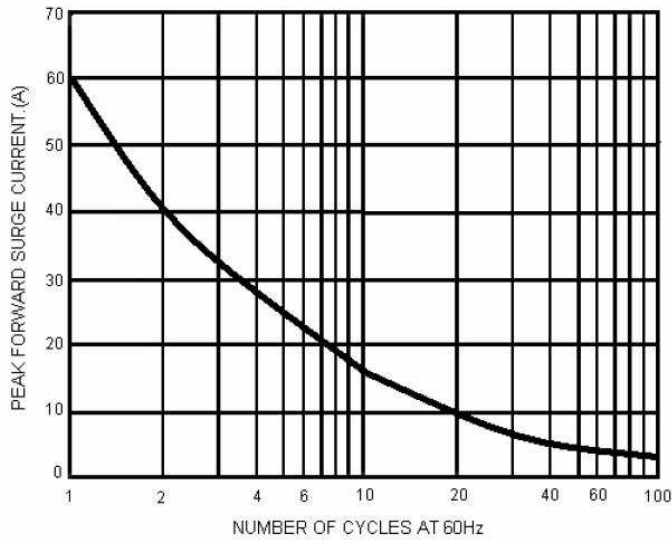

FIG.2-MAXIMUM FORWARD CURRENT DERATING CURVE

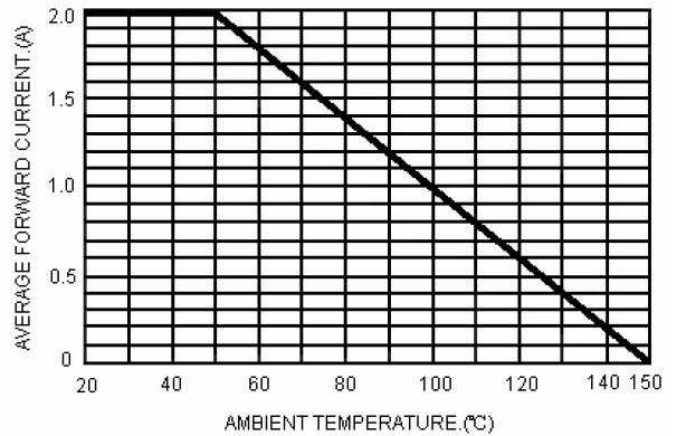

FIG.3-TYPICAL INSTANTANEOUS FORWARD CHARACTERISTICS PER BRIDGE ELEMENT

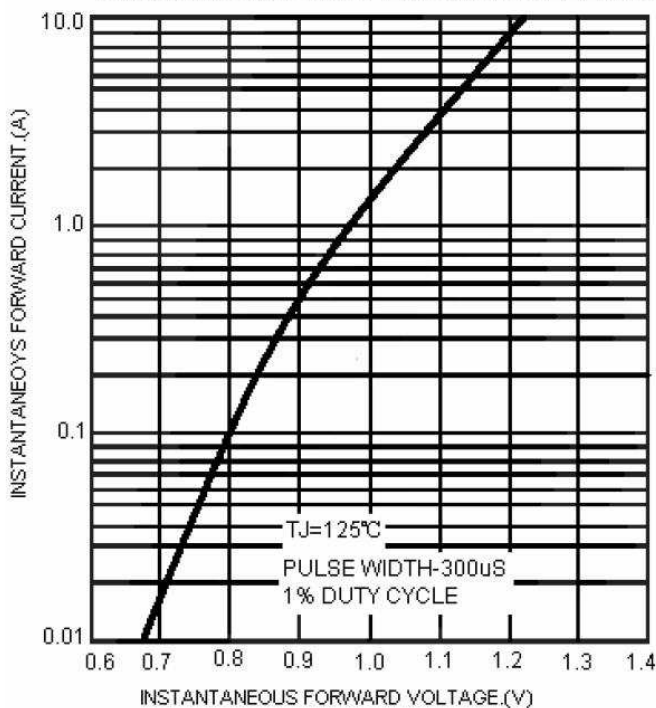
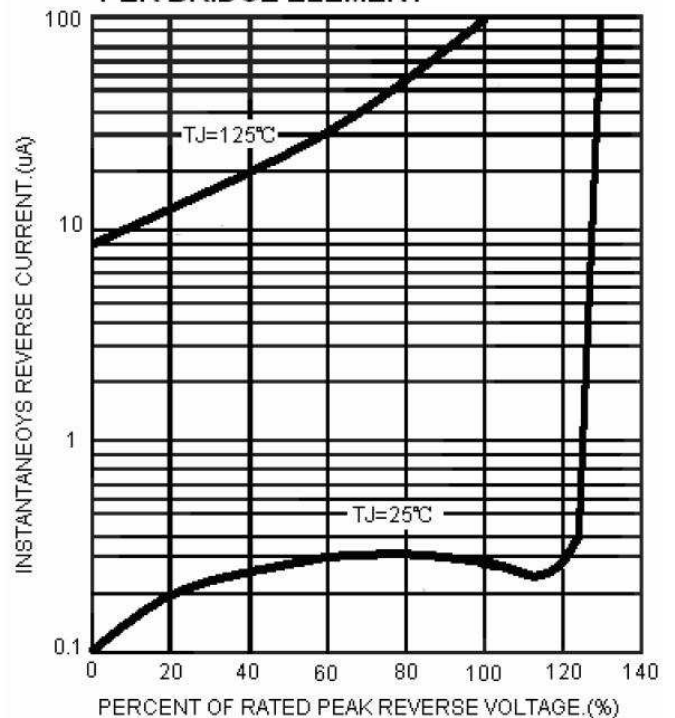

FIG.4-TYPICAL REVERSE CHARACTERISTICS PER BRIDGE ELEMENT



Note: Specification are subject to change without notice. For more detail and update, please visit our website.