

DB101 THRU DB107

Single Phase 1.0 AMPS. Glass Passivated Bridge Rectifiers

Voltage Range 50 to 1000 Volts Current 1.0 Amperes

FEATURES

- ◆ Ideal for printed circuit board
- ◆ Reliable low cost construction technique results in inexpensive product
- ◆ High temperature soldering guaranteed:
260°C / 10 seconds / 0.375" (9.5mm)
lead length at 5 lbs., (2.3 kg) tension
- ◆ UL Recognized File number: E347215

MECHANICAL DATA

- ◆ Case: Molded plastic
- ◆ Lead: solder plated
- ◆ Polarity: As marked

DB

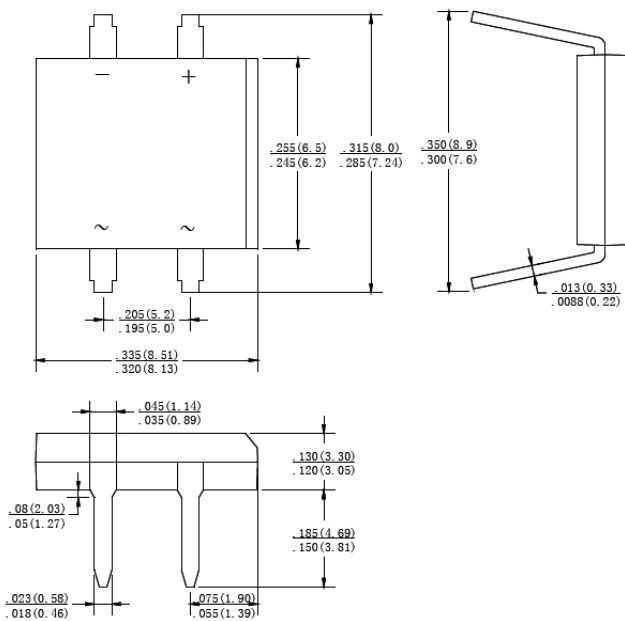

Dimensions in inches and (millimeters)

MAXIMUM RATINGS AND ELECTRICAL CHARACTERISTICS

Rating at 25°C ambient temperature unless otherwise specified.

Single phase, half wave, 60Hz, resistive or inductive load. For capacitive load, derate current by 20%

Type Number		DB101	DB102	DB103	DB104	DB105	DB106	DB107	UNITS
Maximum Repetitive Peak Reverse Voltage	V _{RRM}	50	100	200	400	600	800	1000	V
Maximum RMS Voltage	V _{RMS}	35	70	140	280	420	560	700	V
Maximum DC Blocking Voltage	V _{DC}	50	100	200	400	600	800	1000	V
Maximum Average Forward Rectified Current at T _A =40°C	I _(AV)	1.0							A
Peak Forward Surge Current, 8.3ms Single Half Sine-wave Superimposed on Rated Load (JEDEC method)	I _{FSM}	50							A
Maximum Instantaneous Forward Voltage at 1.0A	V _F	1.1							V
Maximum DC Reverse Current @ T _A =25°C rated DC blocking voltage per leg T _A =125°C	I _R	10 500							μA
Typical Thermal Resistance (Note)	R _{θJA}	40							°C/W
	R _{θJL}	15							
Operating Temperature Range	T _J	-55 to +150							°C
Storage Temperature Range	T _{STG}	-55 to +150							°C

Note: Thermal Resistance from Junction to Ambient and from Junction to Lead Mounted on P.C.B. with 0.47×0.47" (12×12mm) Copper Pads.

DB101 THRU DB107

Single Phase 1.0 AMPS. Glass Passivated Bridge Rectifiers

Voltage Range 50 to 1000 Volts Current 1.0 Amperes

RATING AND CHARACTERISTIC CURVES DB101 THRU DB107

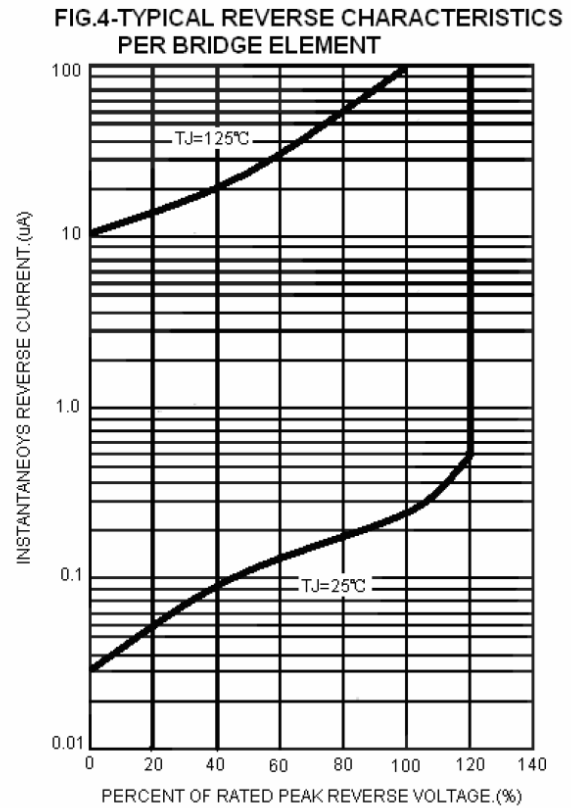
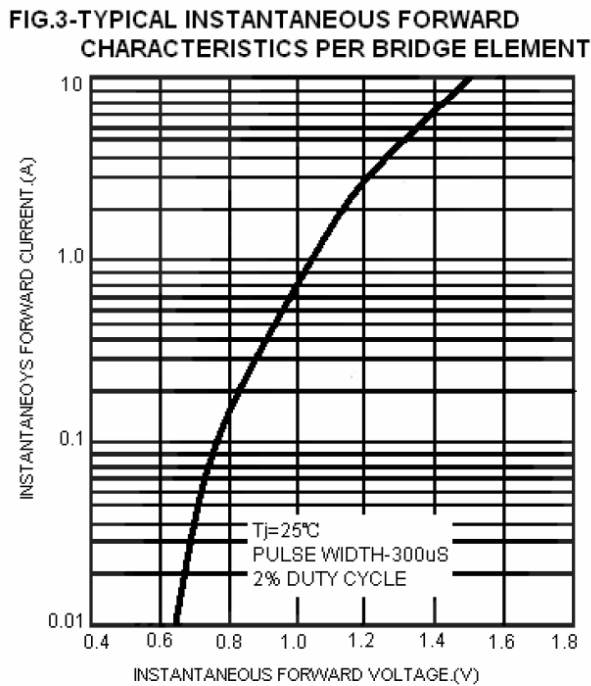
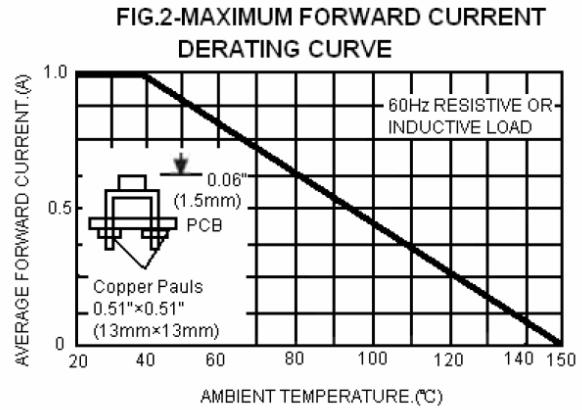
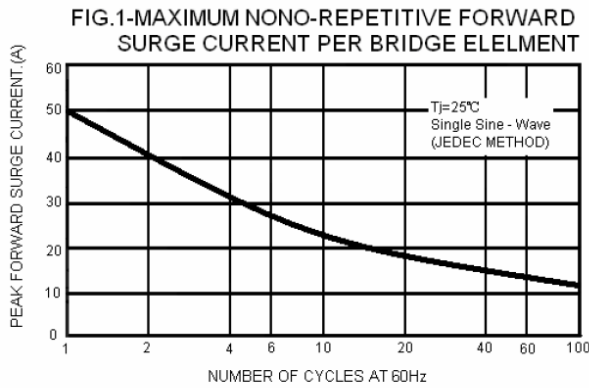

Note: Specification are subject to change without notice. For more detail and update, please visit our website.