

# Trimmer Potentiometer-6mm Ceramic

Suntan®

DISCONTINUED

# TSR-655



## 玻璃釉微調電位器

- 6mm Round/ Single-Turn/ Cermet Industrial/ Open Frame
- Cross slot adjustment options
- Horizontal and vertical mounting styles
- Dust resistant/ splash resistant covers
- PC board stand-offs and retention feature
- Front and top adjust styles

Electrical Characteristics	
Standard Resistance Range	100Ω to 1meg ohm (see standard resistance table)
Resistance Tolerance	±20% (TK±25%)
Adjustment Angle	240° ± 20°
Residual Resistance	≤500Ω, 10Ω>500Ω, 2% (TK≤1KΩ, 2KΩ>1KΩ, 5%)

Environmental Characteristics	
Power Rating Max	100V
Working Voltage	100V
70°C	0.3Watt (TK 0.1Watt)
Temperature Range	-30°C to +85°C (TK -10°C to +70°C)
Temperature Coefficient	±250ppm/°C (TK±1000 ppm/°C)
Rotational Life	±10% (TK±15%)
Load Life	500 hours 0.3Watt 70°C ±5% (TK 240 hours 0.1Watt 50°C +5%/±20%)

Physical Characteristics	
Torque (Operating)	30~300gf. Cm
Stop Strength	0.5kgf. cm
Soldering Conditions	240°C to 260°C And within 3 seconds
Marking	Resistance Code
Standard Packing	500 PCS Per bag
Aqueous cleaning not recommended	

### How to Order

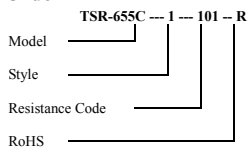

### Standard Resistance table

Resistance(Ohms)	Resistance Code
100	101
220	221
500	501
1,000	102
2,200	222
10,000	103
220,000	224
1,000,000	105

### TSR-655C-1

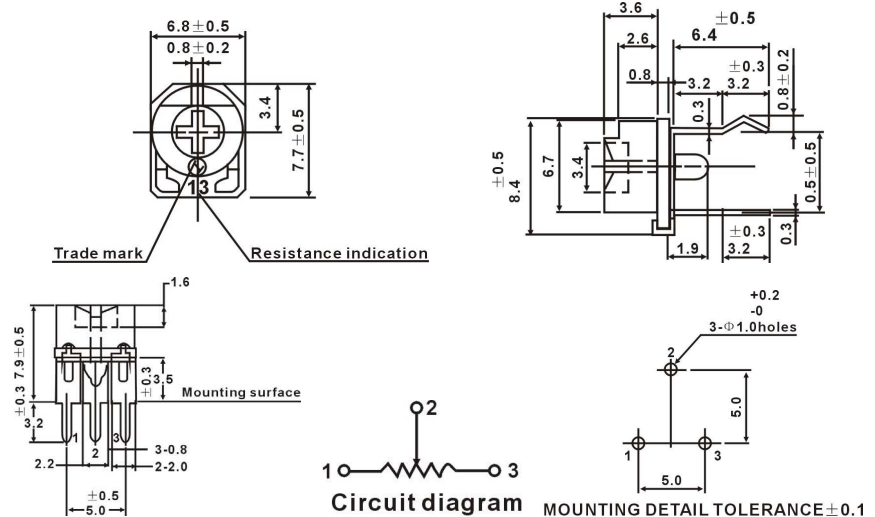

### TSR-655M-1

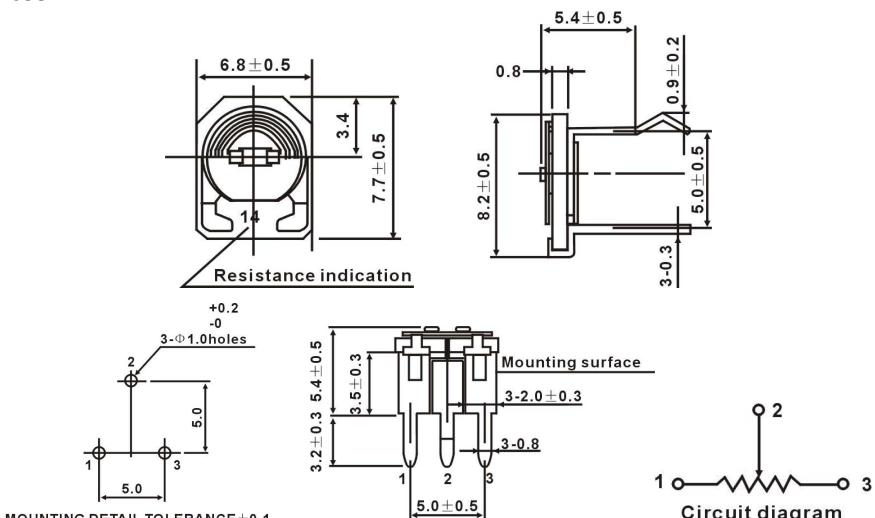

### TSR-655M-S

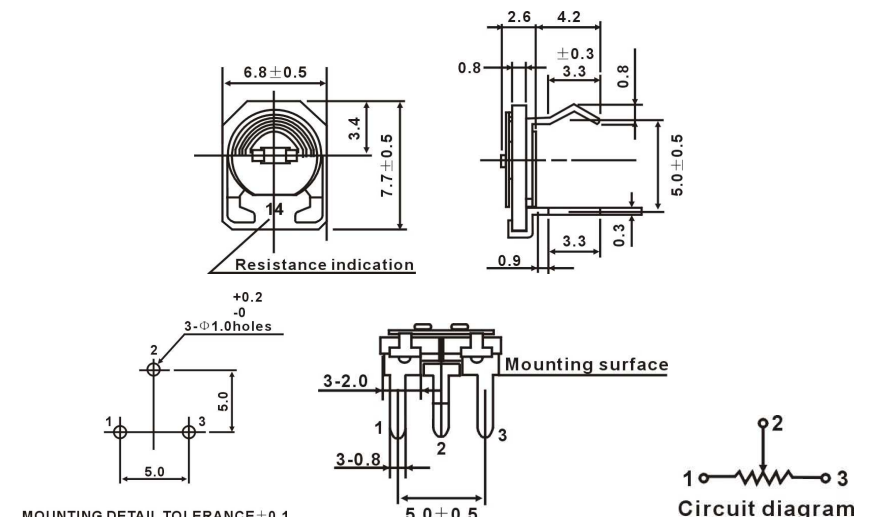

Note: Specification are subject to change without notice. For more detail and update, please visit our website.