

TSC7

(N, V) SERIES

FEATURES

- Wide of capacity ranges
- Long durability of performance guaranteed by both stables
And strong characteristics of capacity against heat humidity and coldness
- Sturdy mechanical structure against vibration or shock

SPECIFICATIONS

OPERATING TEMPERATURE RANGE	-30°C ~ +85°C
RATED WORKING VLOTAGE	100V DC
WITHSTANDING VOLTAGE	500V DC
INSULATION RESISTANCE	10 ⁴ MΩ min
ROTATION TORQUE	40 ~ 200 g.cm
SOLDERING TEMPERATURE	250 ± 5°C



NORMAL TYPE

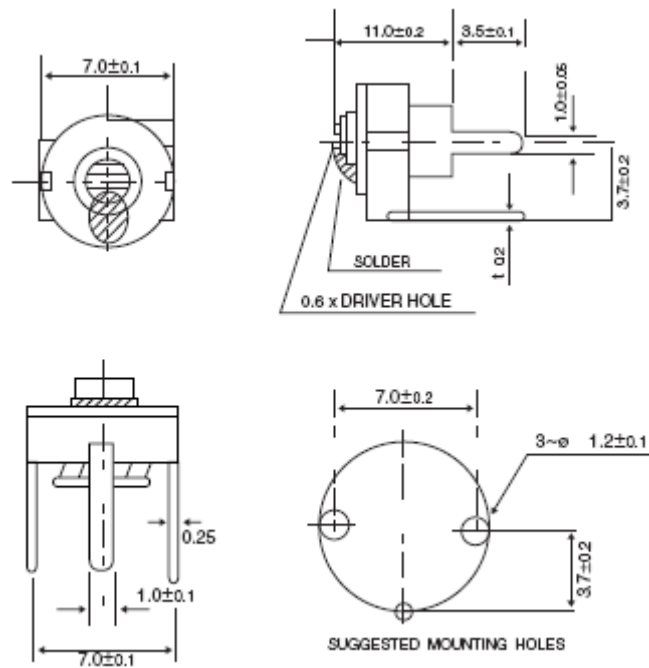

VERTICAL TYPE

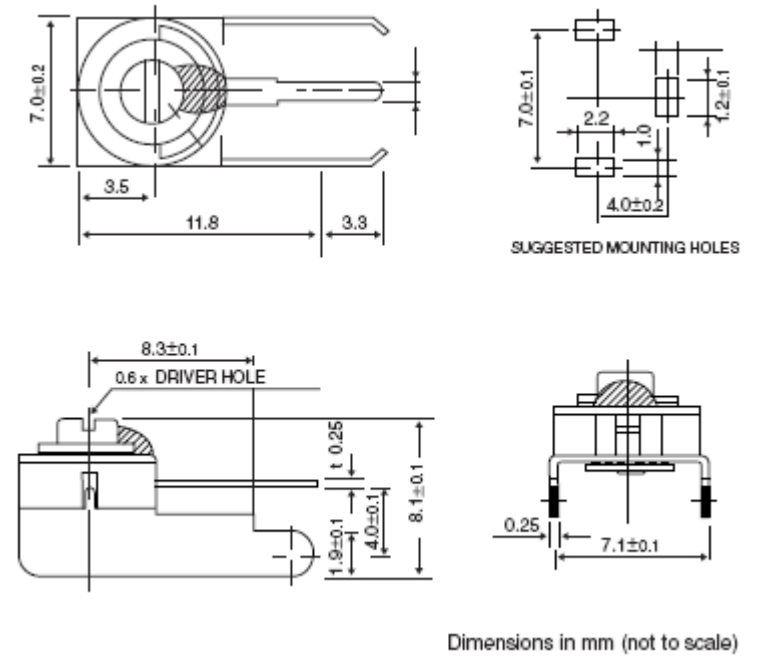

RATINGS

PART NO.	MIN. CAP. (pF)	MAX. CAP. (pF)	TEMP. COEFF. PPM / °C	Q FACTOR @1MHZ Cmax
TSC (N, V)07-050	2.0 max	5.0 ⁺¹⁰⁰ / ₋₀ %	NP 0±200	>300
TSC (N, V)07-100	2.5 max	10.0 ⁺¹⁰⁰ / ₋₀ %	NP 0±200	>300
TSC (N, V)07-200	3.0 max	20.0 ⁺¹⁰⁰ / ₋₀ %	N 470±200	>300
TSC (N, V)07-300	4.5 max	30.0 ⁺¹⁰⁰ / ₋₀ %	N 550±300	>300
TSC (N, V)07-500	6.0 max	50.0 ⁺¹⁰⁰ / ₋₀ %	N 1400±300	>300
TSC (N, V)07-700	8.5 max	70.0 ⁺¹⁰⁰ / ₋₀ %	N 2200±300	>200
TSC (N, V)07-101	12.0 max	100.0 ⁺¹⁰⁰ / ₋₀ %	N 2200±300	>200

V: VERTICAL TYPE N: NORMAL TYPE

Note: Specification are subject to change without notice. For more detail and update, please visit our website.