



CliQ II DIN Rail Power Supply 48V 240W 1Phase



Model No. DRP 048V 240W 1BA
 Weight: 0.97Kg.
 Size: 121 mm X 85 mm X 124.1 mm (H x W x D)

Features

- Reliable design with expected life time of 10 Years
- Compact design for easy handling & installation
- Designed for Class 1 Div. 2 Hazardous Locations environments (conformal coating)
- RoHS Directive 2011/65/EU Compliant
- Efficiency > 91%
- Worldwide AC input range without power derating
- Overload/Overcurrent/Over-Temperature protection
- 150% Power Boost(steady state peak load) for 5 seconds

Description

One of the latest CliQ II offerings from Delta, the World's number 1 power supply company, the DRP048V240W1BA provides an adjustable output, capable of operating from input voltages at 85-264 VAC, at temperature range of -25°C to 80°C. With a rugged aluminum enclosure design that meets shock & vibration requirements of IEC60068-2-6, and conformal-coated PCB assembly, this state-of-the-art design is well suited to a broad variety of industrial applications worldwide.

INPUT SPECIFICATIONS

Input Voltage (Nominal)	100 - 240Vac
Input Voltage range	85 - 264Vac
Input Frequency (Nominal)	50 - 60Hz
Input Frequency range	47 - 63Hz
DC Input Voltage (Nominal)	125 - 250Vdc
DC Input Voltage Range	120 - 375Vdc
Input Current	<2.5A @115Vac, <1.3A @230Vac
Efficiency	> 90.0% @ 115Vac & >91% @ 230Vac
Inrush current (Cold Start)	< 35A @ 115Vac, @ 230Vac
Leakage Current	< 1mA @ 240Vac
Power Factor	>0.96@ 115VAC & >0.90@230VAC

OUTPUT SPECIFICATIONS

Output Voltage (Nominal)	48 Vdc
Output Voltage Tolerance	+/- 1% (Initial set point tolerance)
Output Voltage Adjust Range	48 – 56 Vdc
Line Regulation	< 0.5% Typical @ 85 to 264Vac input, 100% load
Load Regulation	< 1% Typical @ 85 to 264Vac input, 0 to 100% load
Residual Ripple / (PARD), 20MHz BW	< 100mVpp at 85Vac to 265Vac / PARD (200mVpp)
Output Current (Nominal)	5.0 A
Power Derating above 50°C	Derated Linearly 2.5% / °C
Rise Time	< 200ms @ full load (25°C) and typical line input
Start-Up Time	< 1000ms @ full load (25°C) and typical line input
Hold-Up Time	> 20ms @ 115Vac, > 115ms @ 230Vac (100% load, 25°C)
Dynamic Response (with 0.1A/uS slew rate or Vice-a-Versa)	Overshoot & Undershoot to be within +/-2% @10% to 100% of full load
Startup with capacitive loads	10,000µF max @ nominal input & O/P voltage of 48V (25°C)





CliQ II DIN Rail Power Supply 48V 240W 1Phase

Device Description:

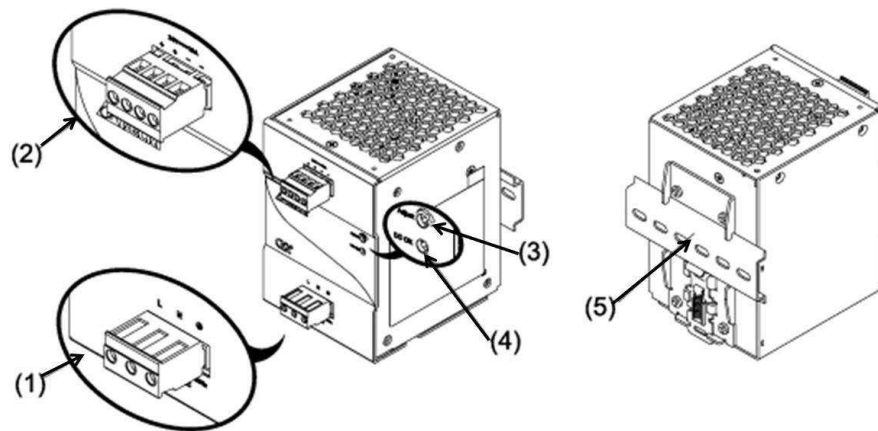

- 1) Input terminal block connector
- 2) Output terminal block connector
- 3) DC voltage adjustment potentiometer
- 4) DC OK control LED (green)
- 5) Universal mounting rail system

Mechanical Drawing:

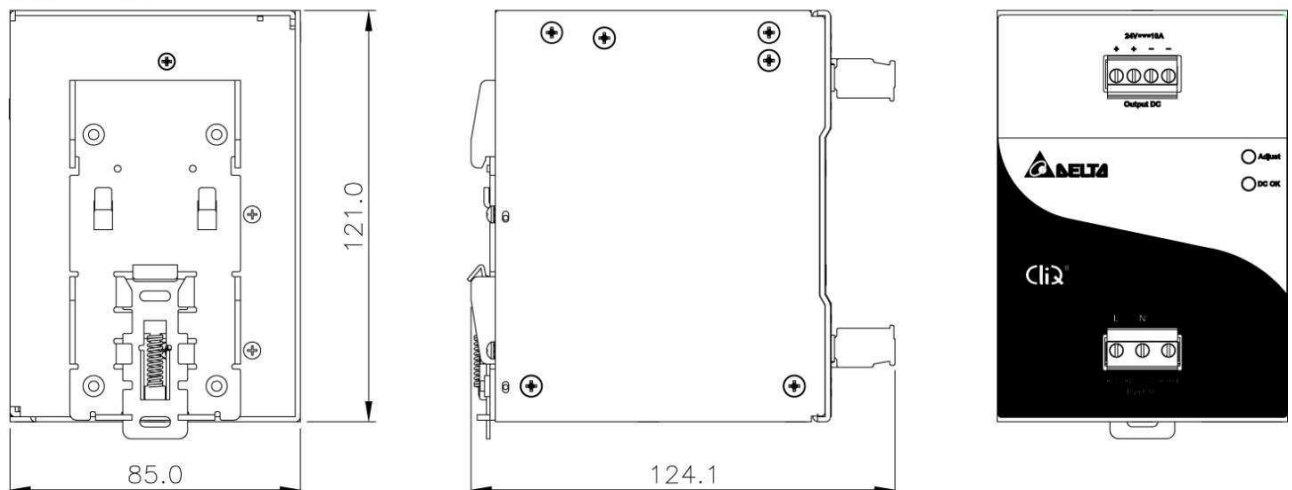

MECHANICAL SPECIFICATION

Dimension	121 mm X 85 mm X 124.1 mm (H x W x D)
Weight	0.97kg
Cooling System	Convection
Input Terminal	Pluggable connector 3 pin (Rated 300V/15A)
Output Terminal	Pluggable connector 4 pin (Rated 300V/15A)
Output Indicator	Green LED (DC OK)
Casing	Aluminum



CliQ II DIN Rail Power Supply 48V 240W 1Phase

Block Diagram:

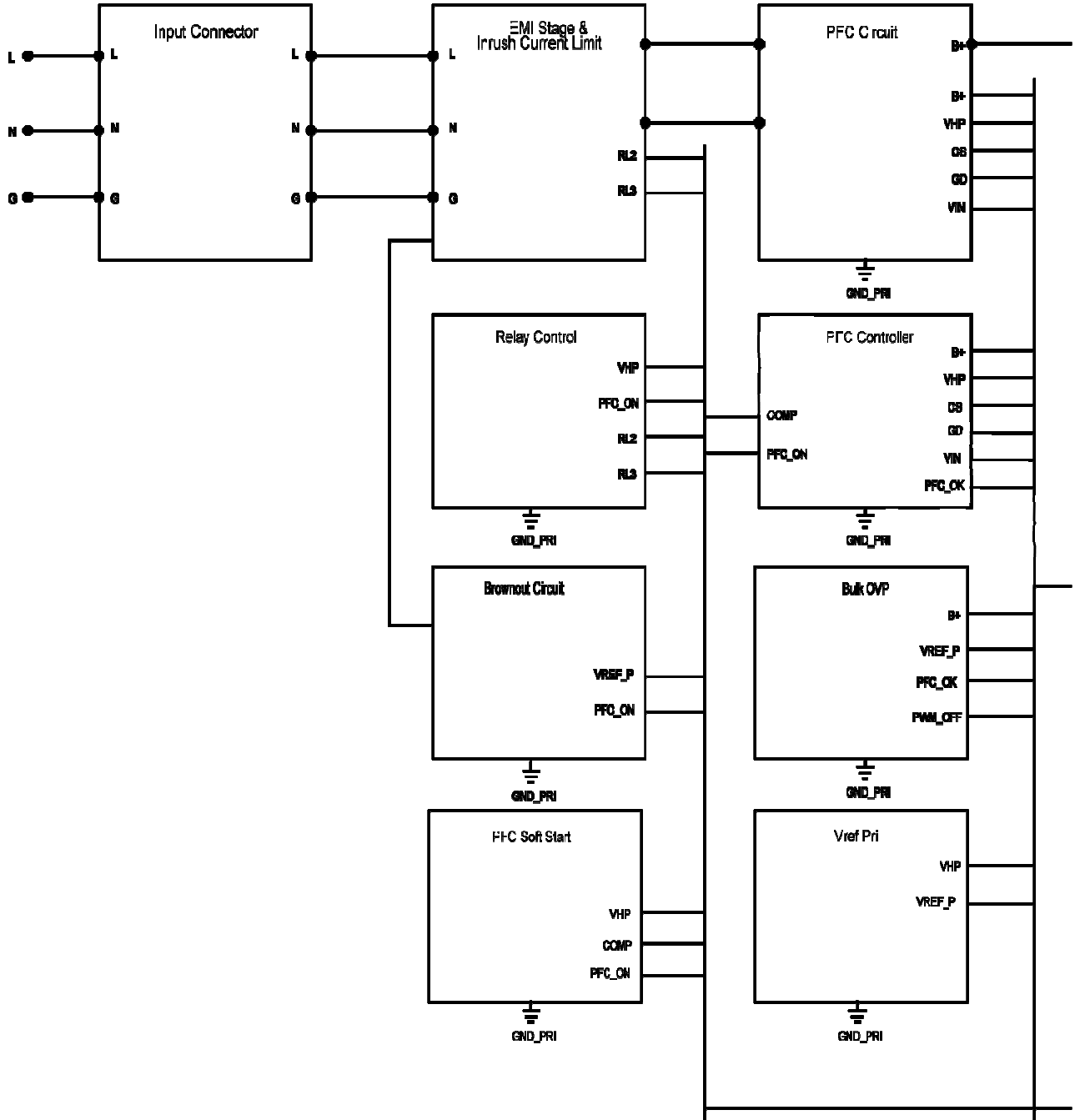



CliQ II DIN Rail Power Supply 48V 240W 1Phase

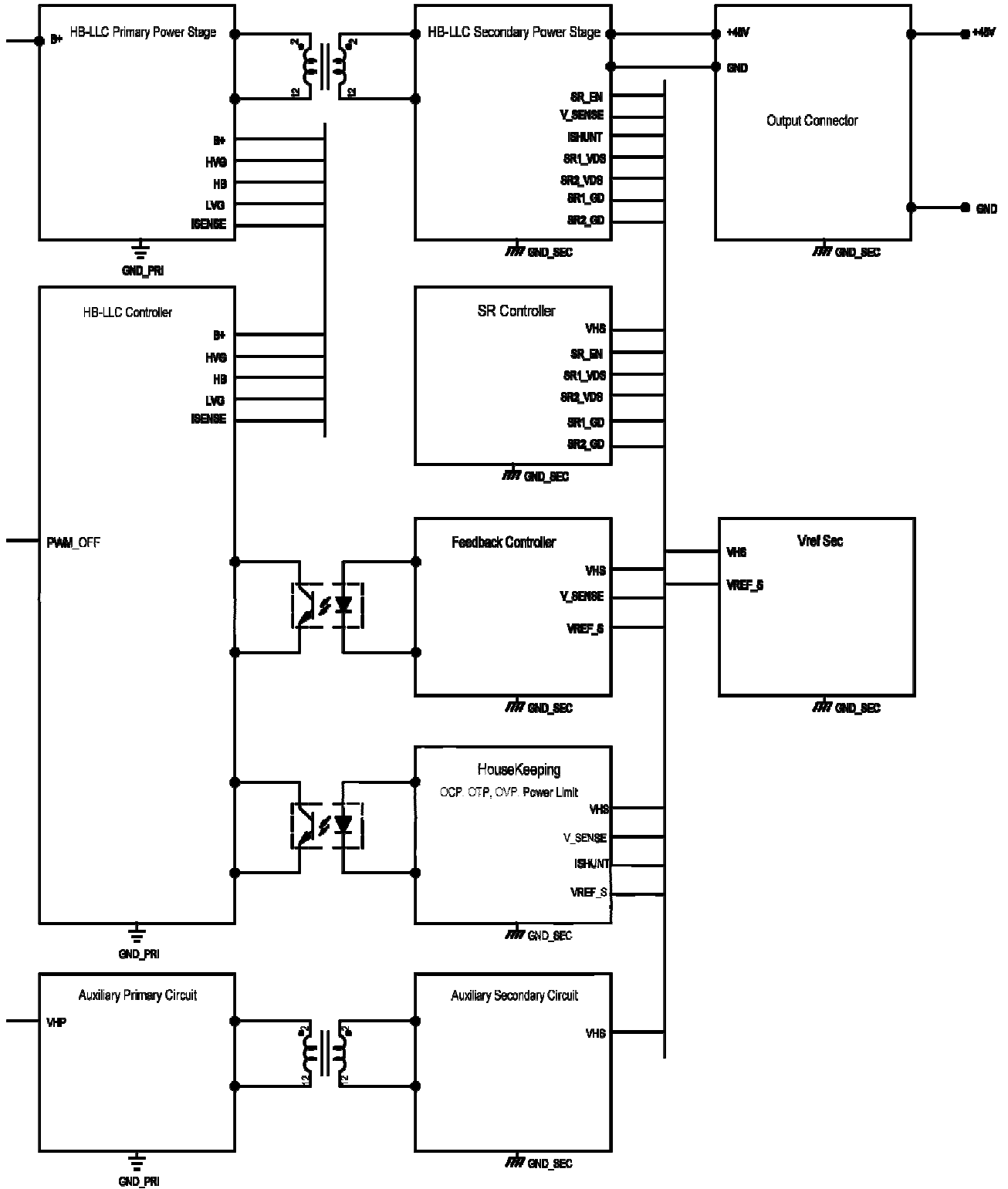



CliQ II DIN Rail Power Supply 48V 240W 1Phase

PROTECTION

Over Voltage Protection	60V +10%/-5%, SELV output, Hicc-up Mode, Non-Latching (Auto recovery).
Over Load, Over Current Protection	> 150% of rated load current, Hicc-up Mode, Non-Latching (Auto recovery).
Over Temperature Protection	< 80°C Ambient Temp@ 100% load. Non-Latching (Auto-recovery).
Short Circuit Protection	Hicc-up Mode, Non-Latching, (Auto-recovery when the fault is removed).

Over Load Protection

The Power Supply is provided with an overload protection (OLP/OCP) function which protects the power supply from possible damage caused by excess current. The Power Supply also has an over temperature protection (OTP) in case overload condition persists for an extended duration and is below the overload trigger point but > 100% load. Typically the overload current (I_{OL}) is > I_{SURGE} (150%) output voltage will start dropping when the power supply reaches max power limit. It will go into bouncing mode when the output reaches UVLO (under voltage point). The output voltage will recover automatically when the overload condition is removed.

Over Temperature Protection

The Power Supply has an over temperature protection (OTP). This is activated when the overload condition persists for an extended duration and the output current is below the overload trigger point but >100% load. In the event of a higher ambient operating condition at 100% load, the Power Supply will run into OTP when the ambient temperature is > 80°C. When activated, the output voltage will go into bouncing mode until the operating ambient temperature drops to 50°C or output capacity is reduced as recommended in the graph.

Over Voltage Protection

The Power Supply has an overvoltage protection (OVP) and is activated when the power supply feedback circuit fails. The output voltage will not be > 57V+10%/-10%, under any Line/Load and operating ambient temperature. The Power Supply does not shut down but goes into Hiccup mode (Auto-Recovery). The output voltage will recover back to 48VDC once the fault is removed.

Short Circuit Protection

The Power Supply has a short circuit protection which is in line with the overload protection and activates whenever there is a short across the output voltage. It will go into bouncing mode and recovers automatically when the fault is removed.





CliQ II DIN Rail Power Supply 48V 240W 1Phase

Derating Curve

(For Horizontal and Vertical)

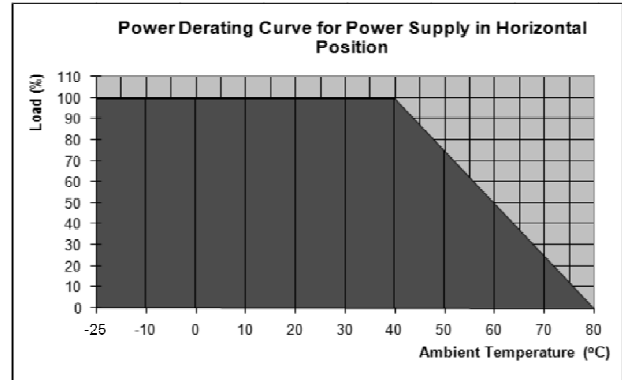
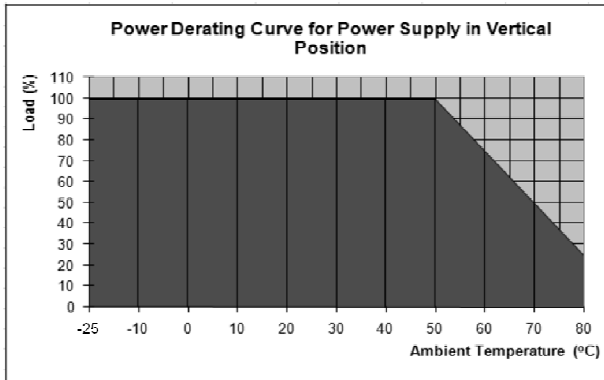

Note

1. Do not use the device in areas outside of the shaded portion shown in the above graph. Internal parts may gradually deteriorate and become damaged.
2. For the power derating refer above graph ambient temperature > 50°C (in vertical) and >40°C (In Horizontal), the output capacity has to be reduced by 2.5% per Celsius increase in temperature. If the output capacity is not reduced when Amb > 50°C (in vertical) and >40°C (In Horizontal), device will run into thermal protection by switching off i.e. device will go in bouncing mode and will recover when Amb is lowered or load is reduced as far as necessary to keep device in working condition.
3. If the device has to be mounted in any other direction, please contact your service provider for more details.
4. In order for the device to function in the manner intended, it is also necessary to observe a lateral spacing of 20mm. from other equipments.
5. Depending on the ambient temperature and output capacity of the device, the device housing can be very hot!

Output Derating VS Input Voltage

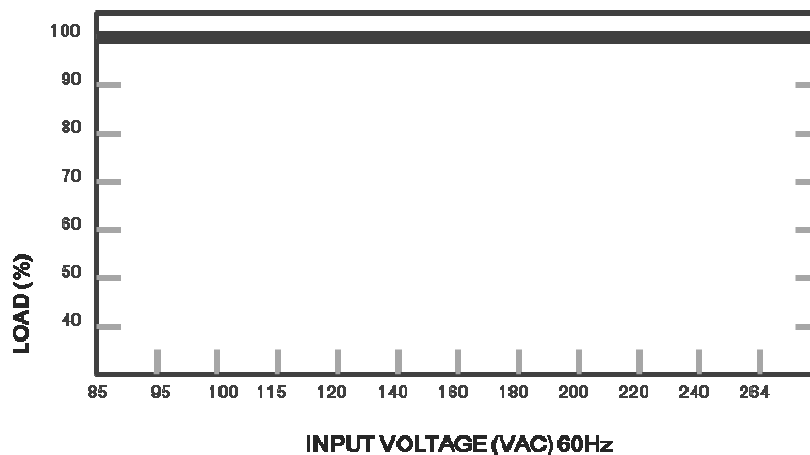

*No output power derating for all range of input



CliQ II DIN Rail Power Supply 48V 240W 1Phase

Over Load Protection

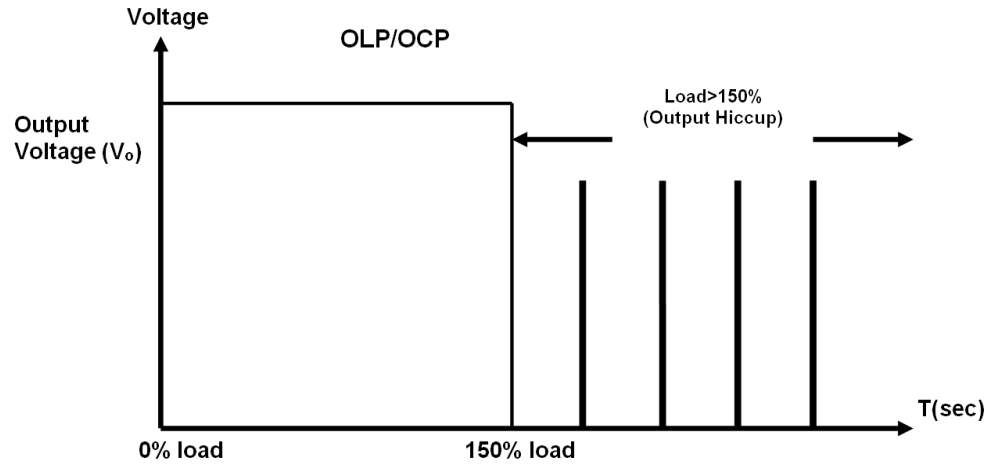

*Typically the over load current (I_{OL}) is $> I_{SURGE}$ (150%) output voltage will start dropping when the power supply reaches max power limit.

Over Voltage Protection

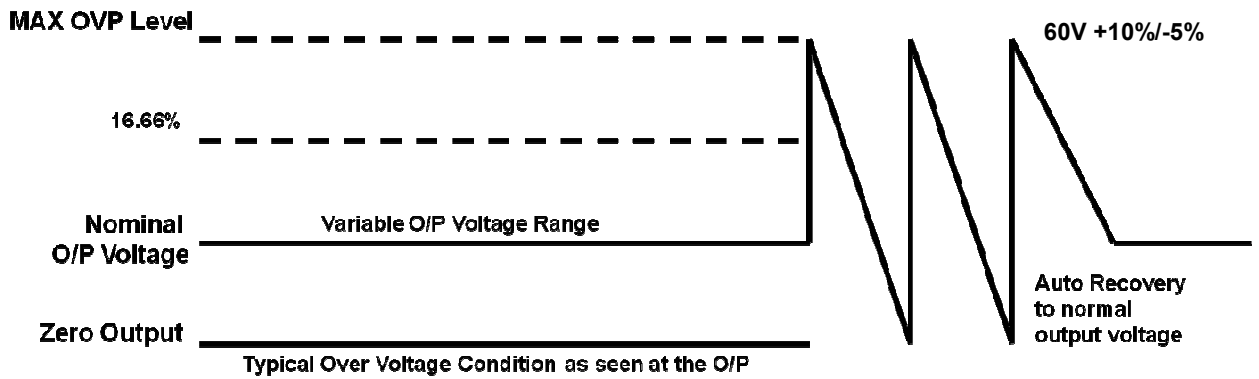

* The Power Supply does not shut down but goes into Hiccup mode (Auto-Recovery). The output voltage will recover back to 48VDC once the fault is removed.



CliQ II DIN Rail Power Supply 48V 240W 1Phase

ENVIRONMENT

Ambient temperature (Operating)	-25°C to +50°C, with operation to 80°C possible with a linear derating to half power from 50°C to 70°C
Operating humidity	< 95%RH
Ambient temperature (Storage)	-25°C to 85°C
Altitude (Operating)	2,500 Meters @ 40°C
Shock Test	IEC60068-2-27, 30G (300m/s ²)
Vibration (Non-Operating)	IEC60068-2-6, 10Hz to 500Hz @ 30m/s ² (3G peak) for all X, Y, Z direction
Bump	IEC60068-2-29, 11ms/ 10gn
MTBF	> 500,000 hrs @ Vertical orientation > 400,000 hrs @ Horizontal orientation Per Telcordia SR 332 and Tested at 115Vac & 230Vac input 100% load, 25°C
Expected Cap Life Time	10 years (115Vac & 230Vac, 50% load and 40°C ambient).
Material and Parts	RoHS Directive 2011/65/EU Compliant, WEEE directive
Degree of protection	IP20
Class of protection	Class I with PE connection
Pollution degree	2

Inrush Current

Inrush current is the first surge current seen on the input side when AC input is applied to the Power Supply. It is the first pulse captured. See below for the Inrush current in a typical Power Supply

Start Up Time

Start-up time is measured from the point AC input is applied to the point output voltage reaches within 90% of its set value. See below for a typical start-up time characteristic.

Rise Time

Rise time is measured from the point output voltage rises from 10% to 90% of its set value. See below for a typical rise time measurement.

Hold Up Time

Hold time is the time when the AC input collapses and o/p voltage retains regulation for a certain period of time is called as hold up time. See in the picture below a typical hold up time characteristic of a power supply. The hold time is measured until the output voltage remains in regulation hence it measured until the output voltage reaches minimum regulation -2% of its set value.

Output Voltage

The 48VDC connection is made using the "+" and "-" screw connections. At the time of delivery, the output voltage is 48VDC. The output voltage can be set from 48 to 56VDC on the potentiometer seen as Adjust on the front panel of each power supply

Surge Load

Typical surge load capability of the power supply, the PSU is capable of delivering 5 Sec. of Surge load about 150% of I_o max the output voltage can be out of regulation limits of ± 5%.

Dynamic Load

Additionally power supply is capable of dynamic change of load from 0% to 100% with output voltage within ±5% of regulation limits. See below the dynamic behavior of the PSU.



CliQ II DIN Rail Power Supply 48V 240W 1Phase

Power Boost 150% for 5 Sec

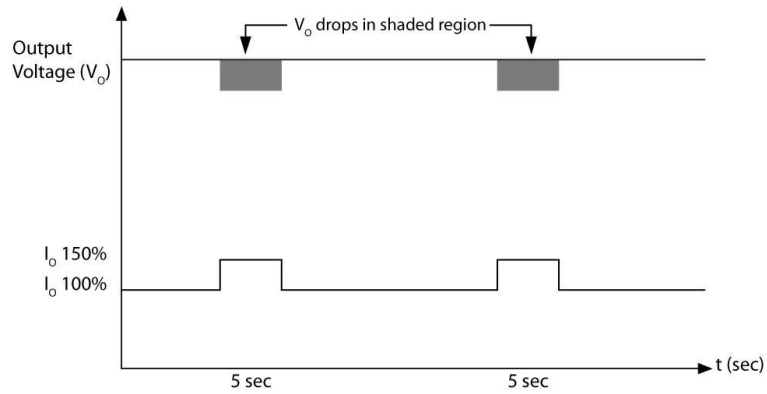

*Surge Load; typical surge load capability of the power supply, the PSU is capable of delivering 5 Sec

Hold Up Time

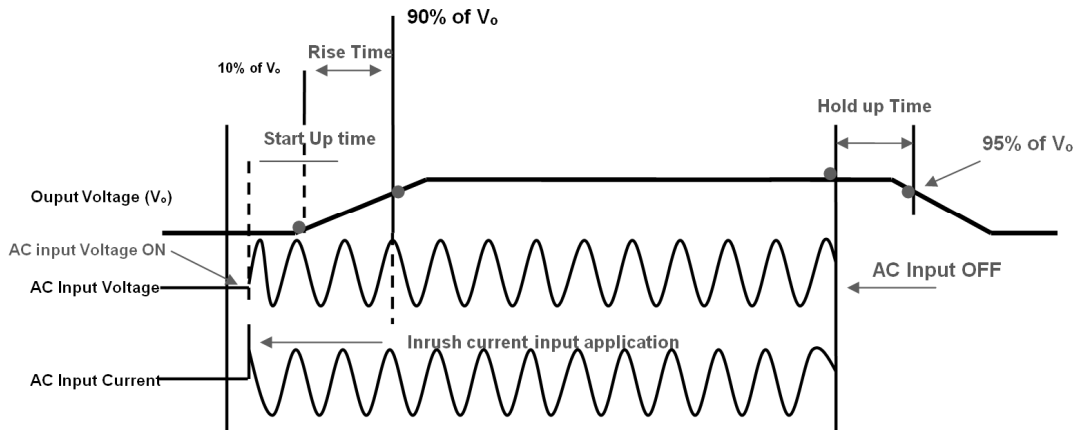

* The hold time is measured until the output voltage remains in regulation hence it measured until the output voltage reaches minimum regulation -2% of its set value.

Dynamic Load

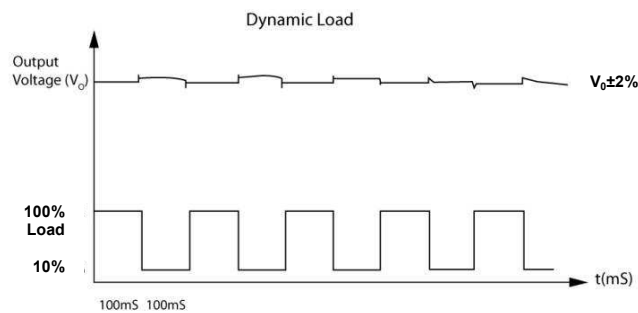

* The power supply is capable of dynamic change of load from 10% to 100% with o/p voltage within $\pm 2\%$ of regulation limits.

Redundancy operation with DRP 20A- (40A)

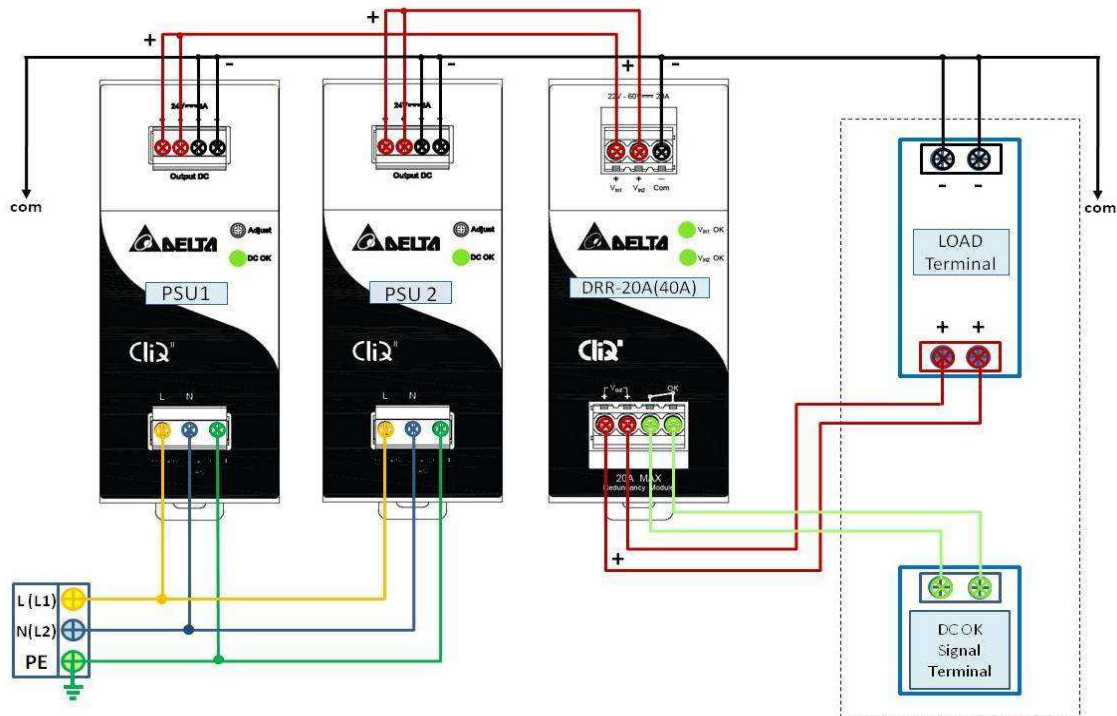

Parallel Operation

When 2 Power Supplies are connected in parallel, they can share the load if the following steps are taken.

Step1. Measure the output voltages at no load from Anode1 to Ground i.e. Voltage Anode1 to Ground of PSU1 and Voltage Anode2 to Ground of PSU2. If the voltages are not the same, follow Step 2. If they are the same, skip to Step 3.

Step2. . Adjust the output voltages, with the help of VR on the Power Supply front panel marked as ADJUST, to the same level. For e.g. if PSU1 is measuring 48.15Vdc and PSU2 is measuring 48.25Vdc, adjust the output voltage of one to be the same as the other

Step3. Connect the Power Supply to the end system load and measure the output voltages from A1 to Ground i.e. Voltage Anode 1 to Ground of PSU1 and Voltage Anode 2 to Ground of PSU2. Ensure that the output voltages are the same even after the 2 Power Supplies are connected to load. If not, adjust them with the VR available on the front panel. A tolerance of +/-25mV would be acceptable.

Note

- 1) If the output voltage of any Power Supply is higher, it will take the initial load and share the maximum load.
- 2) If the output voltages are the same, then an equal load current sharing between the 2 Power Supplies can be achieved.
- 3) The ORing diode must be of an appropriate rating. The rating must be at least 4 times of the output load current and at least reverse voltage rating of 20Vrr.
- 4) The use of a heat sink is advised to ensure the ORing Diode does not overheat.
- 5) Recommended Redundancy Module: DRR-40A



CliQ II DIN Rail Power Supply 48V 240W 1Phase

SAFETY STANDARDS /EMC

SAFETY STANDARD	CCC	Prepared
	Bauart	EN 60950-1
	UL/cUL Listed	to UL508 and CSA C22.2 No.107.1-01 Industrial control equipment
	UR/cUR recognize	to UL 60950-1 and CSA C22.2 No. 60950-1 Information technology equipment
	CE	EMC and Low Voltage directive
	CB	Test certification and report to IEC60950-1
	IEC 62103:2003/EN 50178	Electronic Equipment in power installations
	Ex II3G ATEX 94/9/EC,	Hazardous location for ICE60079-0, IEC60079-15 (pending)

EMI	CISPR22,CISPR11 Class B EN61204-3 EN61000-3-2 EN55022	;FCC Title 47 Class B on AC & Class A on DC Side Limitation of mains harmonic current Class A / Information technology equipment (I.T.E) radio Frequency equipment –Radio disturbance Characteristic
------------	--	---

EMS

• EN 61000-4-2 ¹⁾ Electrostatic Discharge Standard (ESD)	LEVEL 4 Criteria A Air Discharge : 15 KV Contact discharge : 8 KV
• EN 61000-4-3 ¹⁾ Radiate Field Immunity	LEVEL 3 80MHz - 1GHz / 10V/M with 1kHz tone / 80% modulation.
• EN 61000-4-4 ¹⁾ Fast transients (Burst Immunity)	LEVEL 3 Criteria A 2 KV ⁴⁾
• IEC 61000-4-5 ¹⁾ Surge voltage Immunity	LEVEL 3 Criteria A Common Mode : 2 KV ³⁾ Differential Mode : 1 KV ⁴⁾
• EN 61000-4-6 ¹⁾ Conducted Immunity	LEVEL 3 150KHz - 80MHz / 10Vrms.
• EN 61000-4-8 ¹⁾ Power frequency magnetic field	LEVEL 3 Criteria A 10A/Meter
• EN 61000-4-11 ²⁾ Voltage dips	Input 100% dip 1 cycle, Main Buffering > 20ms, Self Recoverable
• IEC 61000-4-12 ¹⁾ Low Energy Pulse Test (Ring Wave)	LEVEL 3 Criteria A Common Mode : 2 KV ³⁾ Differential Mode : 1 KV ⁴⁾

Galvanic Isolation :

Input / output	
type test/routine test :	4.0 KVac/
Input / PE	
type test/routine test :	1.5 KVac/
output / PE	
type test/routine test :	1.5 KVac/

- 1) Criterion A: Normal operating behavior within the defined limits.
- 2) Criterion B: Temporary impairment to operational behavior that is corrected by the device itself.
- 3) Symmetrical: Conductor to conductor.
- 4) Asymmetrical: Conductor to ground.



Delta RoHS Compliant

Restriction of the usage of hazardous substances

The European RoHS Directive 2011/65/EU Compliant limits the maximum impurity level of homogeneous materials such as lead, mercury, cadmium, chrome+, polybrominated flame retardants PBB and PBDE for the use in electrical and electronic equipment. RoHS is the abbreviation for "Restriction of the use of certain hazardous substances in electrical and electronic equipment". All items in the catalog conform to this standard.

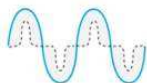

PFC –Norm EN 61000-3-2

Line Current harmonic content

Typically, the input current waveform is not sinusoidal due to the periodical peak charging of the input capacitor. In industrial environment, complying with EN 61000-3-2 is only necessary under special conditions. Complying to this standard can have some technical drawbacks, such as lower efficiency as well as some commercial aspects such as higher purchasing costs. Frequently, the user does not profit from fulfilling this standard, therefore, it is important to know whether it is mandatory to meet this standard for a specific application.



Conformal Coating

The Protective Coating Technology

Delta Electronics Group has designed the perfect dipping technique which penetrates everywhere including under device, and prevents leakage. The conformal coating dipping can be applied to PCBs or circuit board. The coating preserve the performance of precision electronic primarily by preventing ionizable contaminants such as salt from reaching circuit nodes where the material slumps around sharp edges can be a problem especially in the highly conversing atmosphere.