

**Charge Pump and Battery Management ASIC**

**Features**

- Power Manager with Charge Control
- Built-in Battery Protection
- Temperature Compensated Charge Control
- Adjustable Switchover Voltage
- Charges Battery Over a Wide Supply Range
- Low Standby Power
- CBC-910-BUC solder bumped version available
- Eco-Friendly, RoHS Compliant

**Applications**

- **Standby supply** for non-volatile SRAM, Real-time clocks, controllers, supply supervisors, and other system-critical components.
- **Wireless sensors and RFID tags** and other powered, low duty cycle applications.
- **Localized power source** to keep microcontrollers and other devices alert in standby mode.
- **Power bridging** to provide back-up power to system during exchange of main batteries.
- **Consumer appliances** that have real-time clocks; provides switchover power from main supply to backup battery.
- **Business and industrial systems** such as: network routers, point-of-sale terminals, single-board computers, test equipment, multi-function printers, industrial controllers, and utility meters.
- **Energy Harvesting** by coupling the energy storage device with energy transducers such as solar panels.

The CBC910 is a power management solution that provides battery backup control and power management for systems requiring power bridging and/or secondary power.

During normal operation, the CBC910 delivers a controlled voltage using an internal charge pump that operates from 1.5 V to 5.5 V. An ENABLE pin allows for activation and deactivation of the charge pump using an external control line in order to minimize current consumption when battery charge current is not needed.

When the primary power supply dips below a user-defined threshold voltage, the CBC910 will signal this event and route the battery voltage to Vout. The CBC910 also has battery protection circuitry to protect an attached battery from being discharged too deeply.

The CBC910 is available in an 8-pin VDFN package and as a bare die having 9 bond pads.

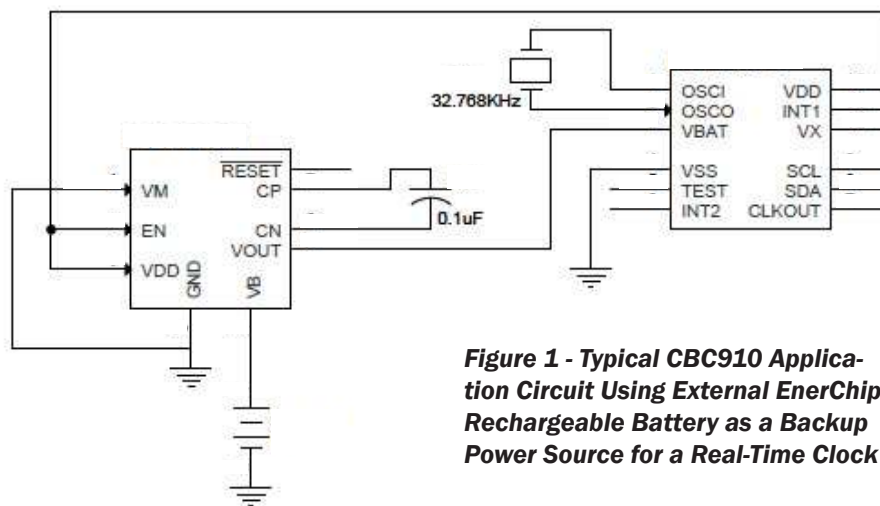

**Figure 1 - Typical CBC910 Application Circuit Using External EnerChip Rechargeable Battery as a Backup Power Source for a Real-Time Clock**

## Electrical Properties

Battery Backup Output voltage: 3.3 V

## Physical Properties

Package size: 3 mm x 3 mm x 0.9 mm

Die size: 0.96 mm x 1.36 mm (to center of scribe on wafer)

Operating temperature: -40 °C to +85 °C

Storage temperature: -40 °C to +125 °C

## Functional Block Diagram

The CBC910 internal schematic is shown in Figure 2. The input voltage from the power supply ( $V_{DD}$ ) is applied to the charge pump, the control logic, and is compared to the user-set threshold as determined by the voltage on  $V_{MODE}$ .  $V_{MODE}$  is an analog input ranging from 0V to  $V_{DD}$ . The ENABLE pin is a digital input that turns off the charge pump when low.  $V_{OUT}$  is either supplied from  $V_{DD}$  or the integrated battery. RESET is a digital output that, when low, indicates  $V_{OUT}$  is being sourced by a backup battery.

$C_{FLY}$  is the flying capacitor in the voltage doubler circuit. The value of  $C_{FLY}$  can be changed if the output impedance of the CBC910 needs to be modified. The output impedance is dictated by  $1/fC$ , where  $f$  is the frequency of oscillation (typically 100kHz) and  $C$  is the capacitor value (typically 0.1 $\mu$ F). GND is system ground.

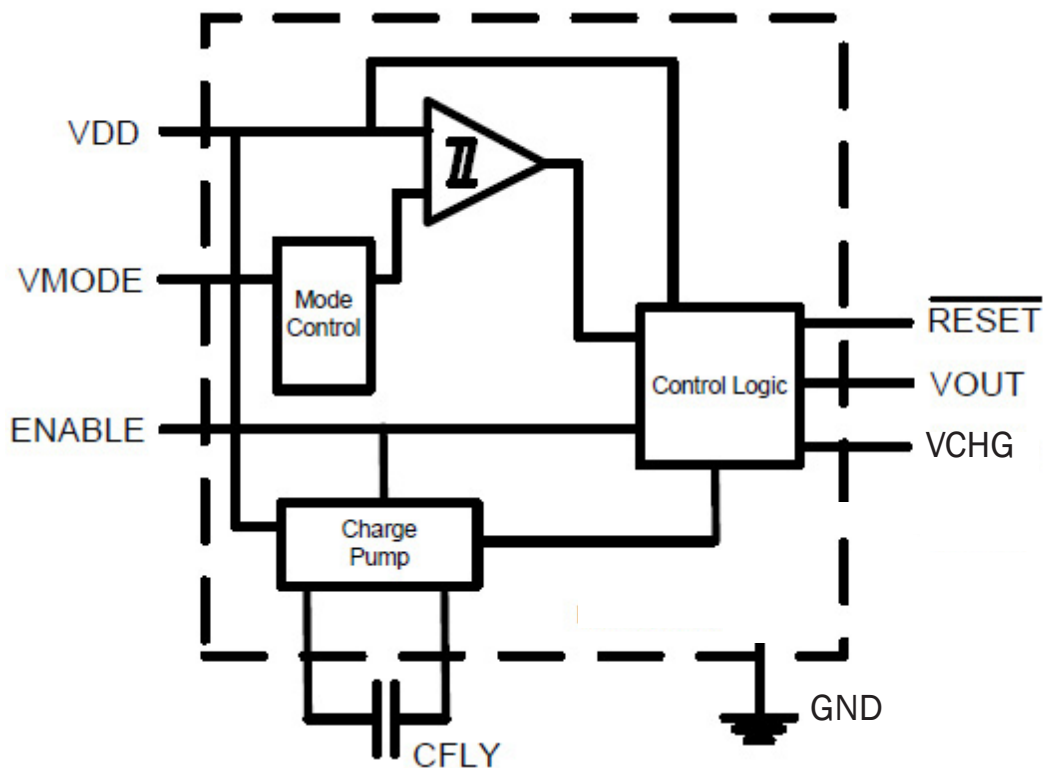
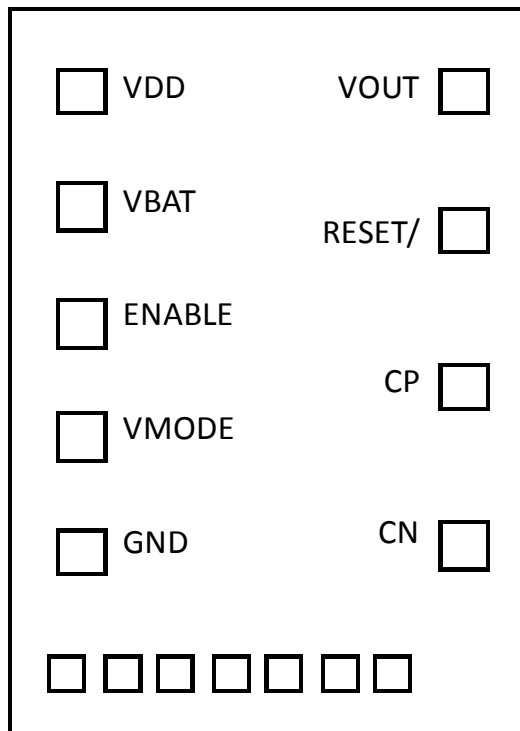

Figure 2: CBC910 Internal Block Diagram

**Device Input/Output Descriptions**

Pin Number	Label	Description
1	VDD	Positive Supply
2	VBAT	4.1V Charging Source
3	EN	Charge Pump Enable
4	GND	Ground
5	CN	Charge Pump Flying Capacitor (-)
6	CP	Charge Pump Flying Capacitor (-)
7	RESET/	Battery Backup Indicator
8	VOUT	Output



**Figure 3: CBC910 Die Pad Designations**

**Absolute Maximum Ratings**

PARAMETER	CONDITION	MIN	TYPICAL	MAX	UNITS
VDD with respect to GND	25 °C	GND - 0.3	-	6.0	V
ENABLE and VMODE Input Voltage	25 °C	GND - 0.3	-	VDD+0.3	V
VBAT <sup>(1)</sup>	25 °C	3.0	-	4.3	V
VOUT	25 °C	GND-0.3	-	6.0	V
RESET Output Voltage	25 °C	GND - 0.3	-	VOUT+0.3	V
CP, Flying Capacitor Voltage	25 °C	GND - 0.3	-	6.0	V
CN	25 °C	GND - 0.3	-	VDD+0.3	V

<sup>(1)</sup> No external connections to this pin is allowed, except rechargeable batteries requiring a 4.1V charge voltage.

**Operating Characteristics**

PARAMETER	CONDITION	MIN	TYPICAL	MAX	UNITS
Output Voltage Vout	VDD > VTH	-	VDD	-	V
Operating Temperature	-	-40	25	85	°C
Storage Temperature	-	-40	-	+125 <sup>(2)</sup>	°C

**Note:** All specifications contained within this document are subject to change without notice.

**POWER SUPPLY CURRENT CHARACTERISTICS****Ta = -40°C to +85°C**

CHARACTERISTIC	SYMBOL	CONDITION	MIN	MAX	UNITS	
Quiescent Current	I <sub>Q</sub>	ENABLE=GND	V <sub>DD</sub> =3.3V	-	3.5	μA
			V <sub>DD</sub> =5.5V	-	6.0	μA
		ENABLE=V <sub>DD</sub>	V <sub>DD</sub> =3.3V	-	35	μA
			V <sub>DD</sub> =5.5V	-	38	μA
Backup Battery Cutoff Current	I <sub>QBATOFF</sub>	V <sub>BAT</sub> < V <sub>BATCO</sub> , V <sub>OUT</sub> =0	-	0.5	nA	
	I <sub>QBATON</sub>	V <sub>BAT</sub> > V <sub>BATCO</sub> , ENABLE=V <sub>DD</sub> , I <sub>OUT</sub> =0	-	42	nA	

**INTERFACE LOGIC SIGNAL CHARACTERISTICS****V<sub>DD</sub> = 2.5V to 5.5V, Ta = -40°C to +85°C**

CHARACTERISTIC	SYMBOL	CONDITION	MIN	MAX	UNITS
High Level Input Voltage	V <sub>IH</sub>	-	V <sub>DD</sub> - 0.5	-	Volts
Low Level Input Voltage	V <sub>IL</sub>	-	-	0.5	Volts
High Level Output Voltage	V <sub>OH</sub>	V <sub>DD</sub> > V <sub>TH</sub> (see Figures 4 and 5) I <sub>L</sub> =10μA	V <sub>DD</sub> - 0.04V <sup>(1)</sup>	-	Volts
Low Level Output Voltage	V <sub>OL</sub>	I <sub>L</sub> = -100μA	-	0.3	Volts
Logic Input Leakage Current	I <sub>IN</sub>	0 < V <sub>IN</sub> < V <sub>DD</sub>	-1.0	+1.0	nA

<sup>(1)</sup> *RESET* tracks V<sub>DD</sub>; *RESET* = V<sub>DD</sub> - (I<sub>OUT</sub> × R<sub>OUT</sub>).**RESET SIGNAL AC/DC CHARACTERISTICS****V<sub>DD</sub> = 2.5V to 5.5V, Ta = -40°C to +85°C**

CHARACTERISTIC	SYMBOL	CONDITION	MIN	MAX	UNITS
V <sub>DD</sub> Rising to <i>RESET</i> Rising	t <sub>RESETH</sub>	V <sub>DD</sub> rising from 2.8V TO 3.1V in <10μs	60	200	ms
V <sub>DD</sub> Falling to <i>RESET</i> Falling	t <sub>RESETL</sub>	V <sub>DD</sub> falling from 3.1V to 2.8V in <100ns	0.5	2	μs
Mode 1 TRIP V V <sub>DD</sub> Rising	V <sub>RESET</sub>	V <sub>MODE</sub> = GND	2.80	3.20	V
Mode 2 TRIP V <sup>(2)</sup> V <sub>DD</sub> Rising	V <sub>RESET</sub>	V <sub>MODE</sub> = V <sub>DD</sub> /2	2.25	2.60	V
<i>RESET</i> Hysteresis Voltage <sup>(3)</sup> (V <sub>DD</sub> to <i>RESET</i> )	V <sub>HYST</sub>	V <sub>MODE</sub> =V <sub>DD</sub>	60	100	mV
		V <sub>MODE</sub> =GND	45	75	
		V <sub>MODE</sub> = V <sub>DD</sub> /2	30	50	

<sup>(2)</sup> User-selectable trip voltage can be set by placing a resistor divider from the V<sub>MODE</sub> pin to GND. Refer to Figure 8.<sup>(3)</sup> The hysteresis is a function of trip level in Mode 2. Refer to Figure 9.

**CHARGE PUMP CHARACTERISTICS****V<sub>DD</sub> = 2.5V to 5.5V, T<sub>a</sub> = -40°C to +85°C**

CHARACTERISTIC	SYMBOL	CONDITION	MIN	MAX	UNITS
ENABLE=V <sub>DD</sub> to Charge Pump Active	t <sub>CPON</sub>	ENABLE to 3rd charge pump pulse, V <sub>DD</sub> =3.3V	60	80	μs
ENABLE Falling to Charge Pump Inactive	t <sub>CPOFF</sub>	-	0	1	μs
Charge Pump Frequency	f <sub>CP</sub>		-	120	KHz <sup>(1)</sup>
Charge Pump Resistance	R <sub>CP</sub>	Delta V <sub>BAT</sub> , for I <sub>BAT</sub> charging current of 1μA to 100μA C <sub>FLY</sub> =0.1μF, C <sub>BAT</sub> =1.0μF	150	300	Ω
V <sub>CHG</sub> Output Voltage	V <sub>CP</sub>	C <sub>FLY</sub> =0.1μF, C <sub>BAT</sub> =1.0μF, I <sub>OUT</sub> =1μA, Temp=+25°C	4.075	4.125	V
V <sub>CHG</sub> Temp. Coefficient	T <sub>CCP</sub>	I <sub>OUT</sub> =1μA, Temp=+25°C	-2.0	-2.4	mV/°C
Charge Pump Current Drive	I <sub>CP</sub>	I <sub>BAT</sub> =1mA C <sub>FLY</sub> =0.1μF, C <sub>BAT</sub> =1.0μF	1.0	-	mA
Charge Pump on Voltage	V <sub>ENABLE</sub>	ENABLE=V <sub>DD</sub>	2.5	-	V

<sup>(1)</sup> f<sub>CP</sub> = 1/t<sub>CPPER</sub>**ADDITIONAL CHARACTERISTICS****T<sub>a</sub> = -40°C to +85°C**

CHARACTERISTIC	SYMBOL	CONDITION	LIMITS		UNITS
			MIN	MAX	
V <sub>BAT</sub> Cutoff Threshold	V <sub>BATCO</sub>	I <sub>OUT</sub> =1μA	2.75	3.25	V
Cutoff Temp. Coefficient	T <sub>CCO</sub>	-	+1	+2	mV/°C
V <sub>BAT</sub> Cutoff Delay Time	t <sub>COFF</sub>	V <sub>BAT</sub> from 40mV above to 20mV below V <sub>BATCO</sub> I <sub>OUT</sub> =1μA	40	-	ms
V <sub>OUT</sub> Dead Time, V <sub>DD</sub> Rising <sup>(2)</sup>	t <sub>RSBR</sub>	I <sub>OUT</sub> =1mA V <sub>BAT</sub> =4.1V	0.2	2.0	μs
V <sub>OUT</sub> Dead Time, V <sub>DD</sub> Falling <sup>(2)</sup>	t <sub>RSBF</sub>	V <sub>BAT</sub> =4.1V	0.2	2.0	μs
Bypass Resistance	R <sub>OUT</sub>	-	-	2.5	Ω

<sup>(2)</sup> Dead time is the time period when the V<sub>OUT</sub> pin is floating. Size the holding capacitor accordingly.**Note: All specifications contained within this document are subject to change without notice**

Important timing diagrams for the CBC910 relationship between Battery Switchover Timing and Battery Disconnect from Load Timing are shown in Figure 4.

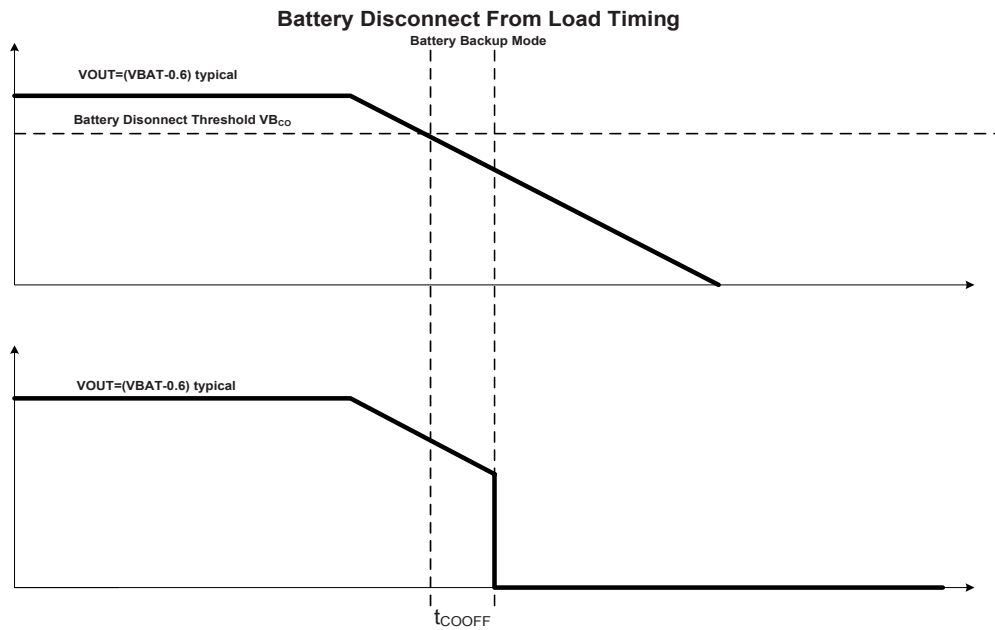
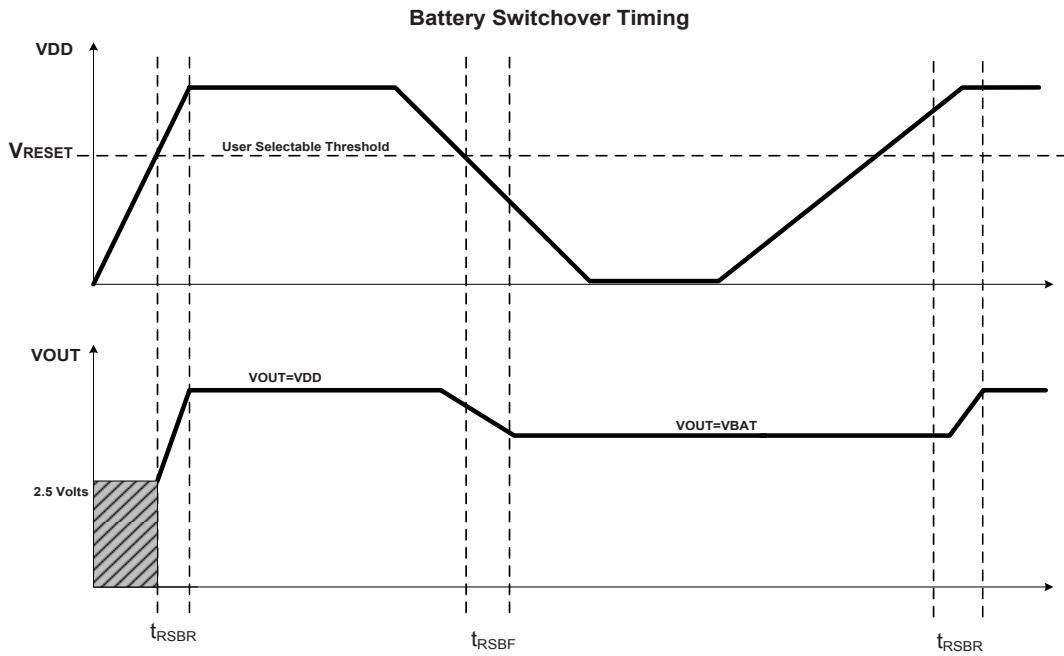

**Figure 4: CBC910 Switchover and Disconnect Timing Diagrams**

Timing diagrams for the CBC910 relationship between VDD to  $\overline{\text{RESET}}$  and ENABLE high to charge pump becoming active are shown in Figure 5.

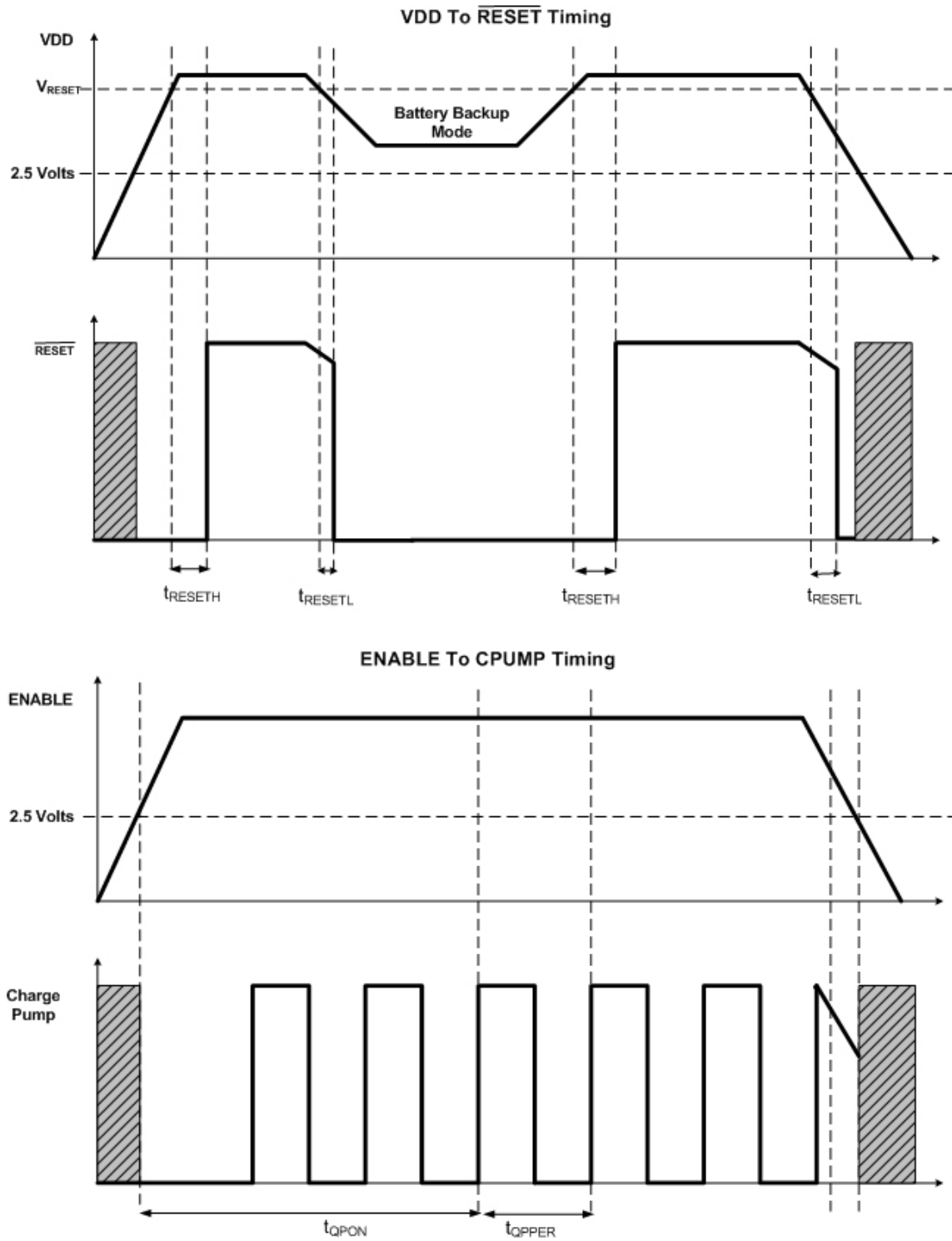

Figure 5: Timing Diagrams for VDD to  $\overline{\text{RESET}}$  and Enable to Charge Pump Active.

### CBC910 Detailed Description

The CBC910 uses a charge pump to generate the supply voltage for charging a battery. An internal FET switch with low  $R_{DS(on)}$  is used to route  $V_{DD}$  to  $V_{OUT}$  during normal operation when main power is above the battery switchover threshold voltage. When  $V_{DD}$  is below the battery switchover threshold voltage, the FET switch is shut off and  $V_{OUT}$  is supplied by the battery through a silicon diode in series between  $V_{BAT}$  and  $V_{OUT}$ . An interrupt signal is asserted low prior to the switchover.

### Operating Modes

The EnerChip CC can be operated from various power supplies such as a primary source or a non-rechargeable battery. With the ENABLE pin asserted high, the charge pump is active and charges the integrated EnerChip. The EnerChip CC will be 80% charged within 10 minutes. Due to the rapid recharge it is recommended that, once the EnerChip CC is fully charged, the user de-assert the ENABLE pin (i.e., force low) to reduce power consumption. A signal generated from the MCU could be used to enable and disable the EnerChip CC.

When controlling the ENABLE pin by way of an external controller - as opposed to fixing the ENABLE line to VDD - ensure that the ENABLE pin is forced low by the controller anytime the  $\overline{RESET}$  line is low, which occurs when the switchover threshold voltage is reached and the device is placed in backup mode. Although the internal charge pump is designed to operate below the threshold switchover level when the ENABLE line is active, it is recommended that the ENABLE pin be forced low whenever  $\overline{RESET}$  is low to ensure no parasitic loads are placed on the EnerChip while in this mode. If ENABLE is high or floating while VDD is in an indeterminate state, bias currents within the EnerChip CC could flow, placing a parasitic load on the EnerChip that could dramatically reduce the effective backup operating time.

#### Mode 1 Operation

For use in 3.3 volt systems. The  $V_{MODE}$  pin should be tied directly to GND. This will set the battery switchover threshold at approximately 3.0 volts.

#### Mode 2 Operation

To adjust the user-selectable battery switchover threshold to a value between 2.5 and 5.0 volts, refer to Figure 6 to determine the value of  $R1$ . To determine the amount of hysteresis from the backup battery switchover threshold, use Figure 7.

Battery charging and backup power for 2.5 to 5.5 volt operation is selected by changing the value of R2. To determine the battery backup switchover point, set the value of R1 to 200kΩ and choose the value of R2 according to Figure 6. For example, to set a 3.0V trip point: If R1=200 kΩ then R2 = R1 x 0.72 = 144kΩ.

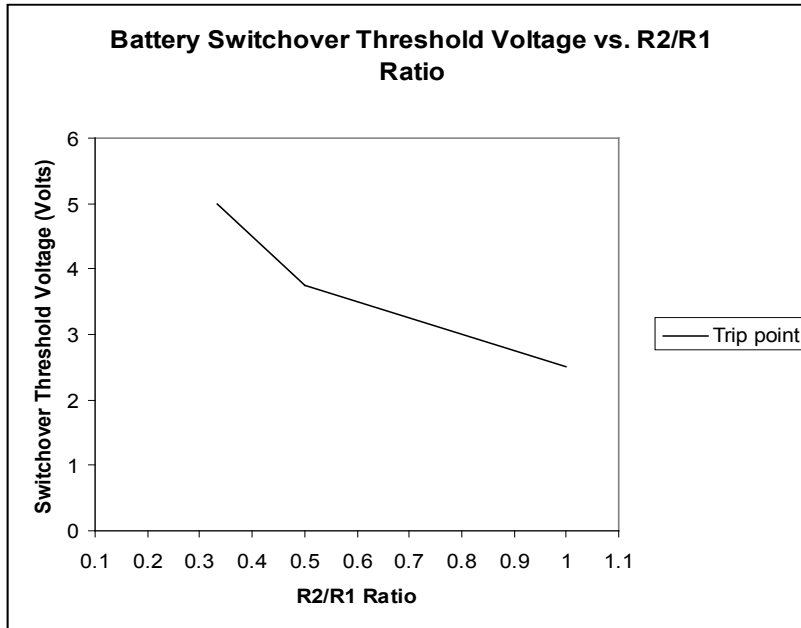

Figure 6: MODE 2 Resistor Selection Graph

To determine the battery backup switchover hysteresis for Mode 2 operation, use Figure 7.

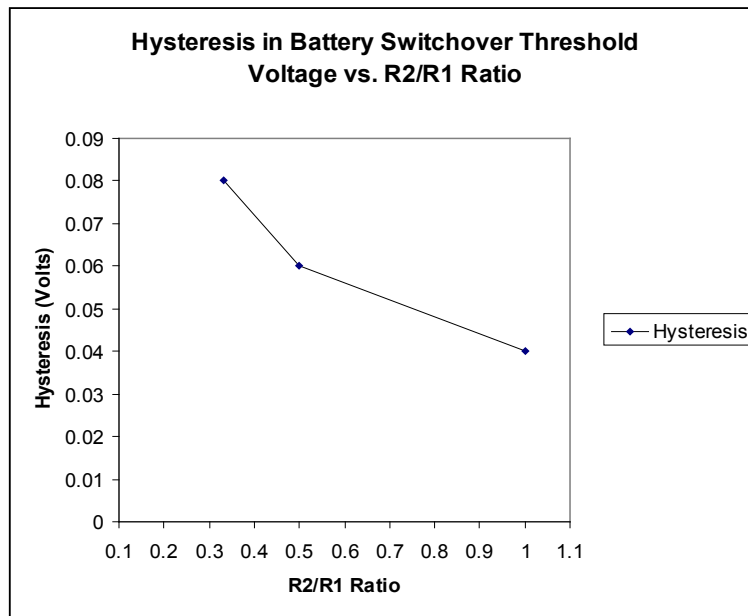
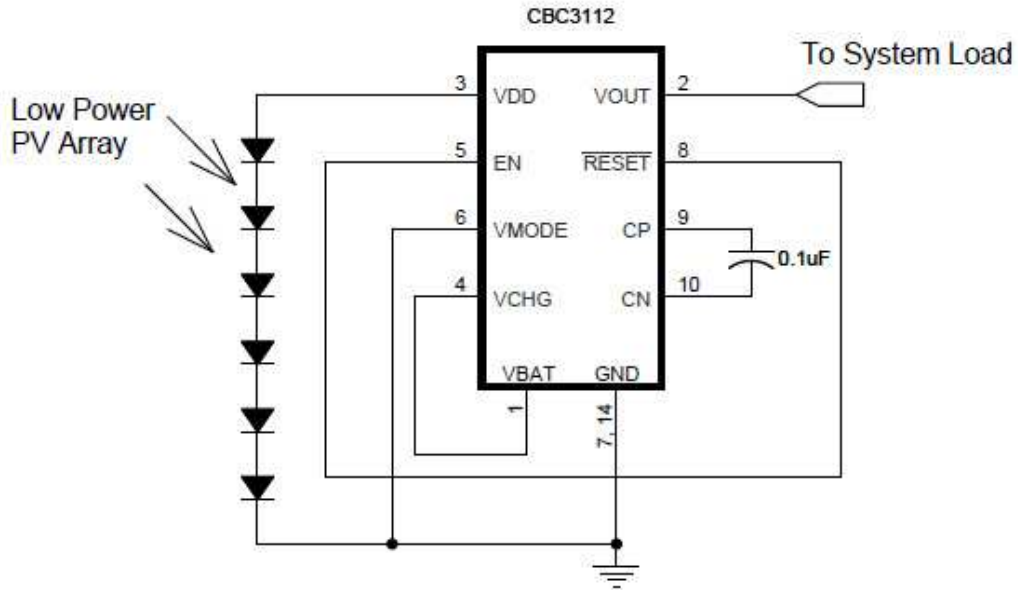

Figure 7: Mode 2 Hysteresis as a Function of R2/R1

**Energy Harvesting with the EnerChip CC**

The EnerChip CC can be configured to collect energy from transducers such as low power photovoltaic (PV) cells and use that harvested energy to charge the integrated EnerChip and deliver self-sustaining power to components such as microcontrollers, sensors, and radios in wireless systems. The schematic of Figure 8 illustrates the feedback connection made from RESET to EN to implement the energy harvesting function with a CBC3112. In order to make most efficient use of the power available from the transducer (for example, a PV cell), it is necessary to know the electrical characteristics including voltage and peak power point of the transducer being used. For assistance in designing your system to effectively harvest energy from a power transducer in a specific environment, contact Cymbet Applications Engineering.



**Figure 8: Implementing Energy Harvesting with the CBC910 Embedded in a Package with an EnerChip**

CBC910 8L VDFN

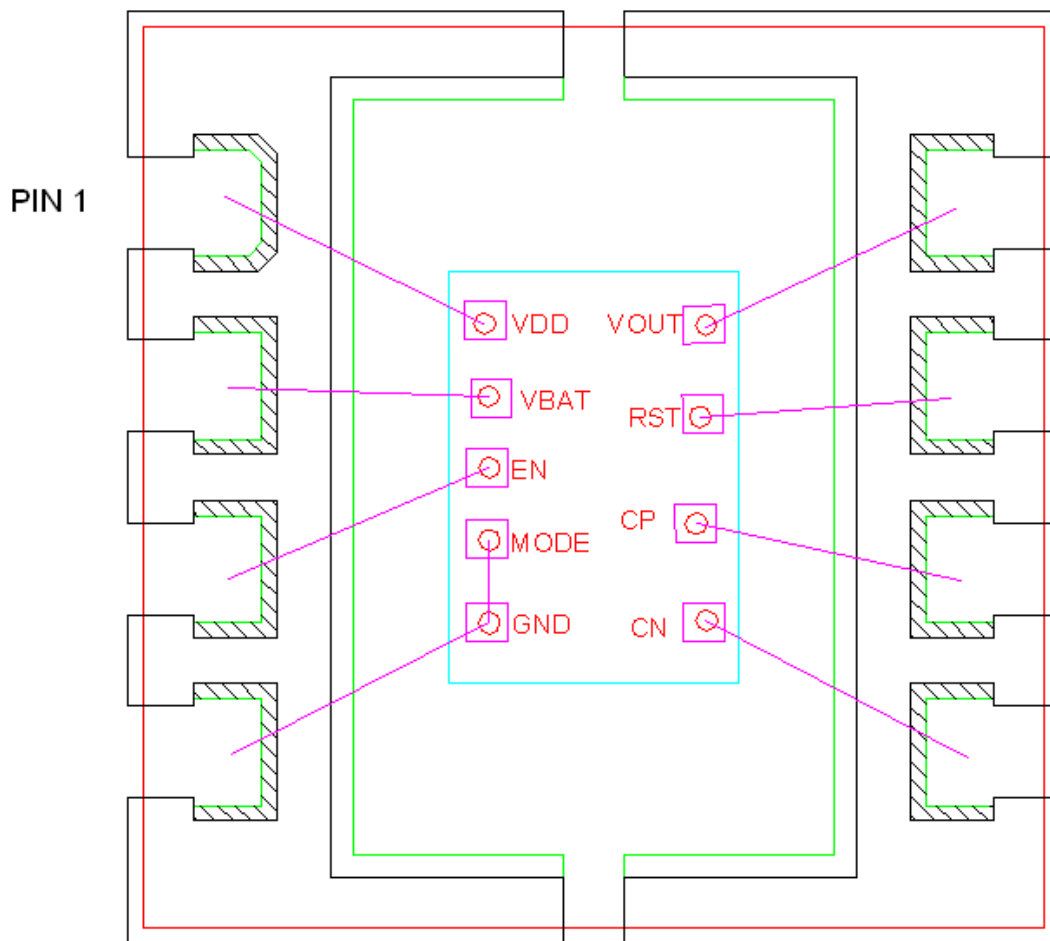
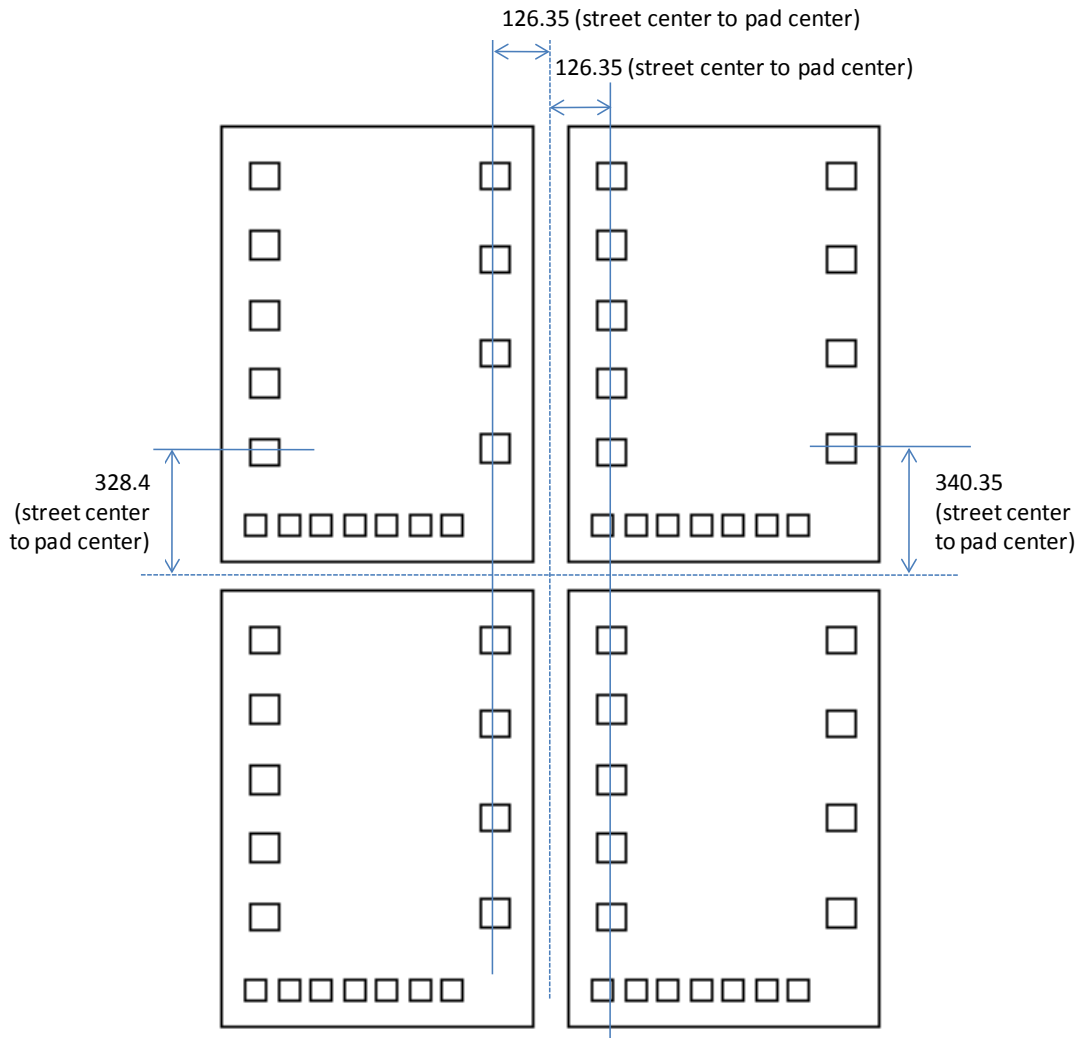

Figure 9: CBC910 8L VDFN Wirebond Diagram

Notes:

Pad size = 1.75mm x 2.66mm  
Pad pitch = 0.61mm

**CBC910 Partial Wafer Map**



Notes:

- 1) Scribe lane is  
 150um (x)  
 150um (y)
- 2) Die thickness is  
 150um minimum.  
 200um maximum.
- 3) All dimensions in microns.

**CBC910 Die Pad Locations**

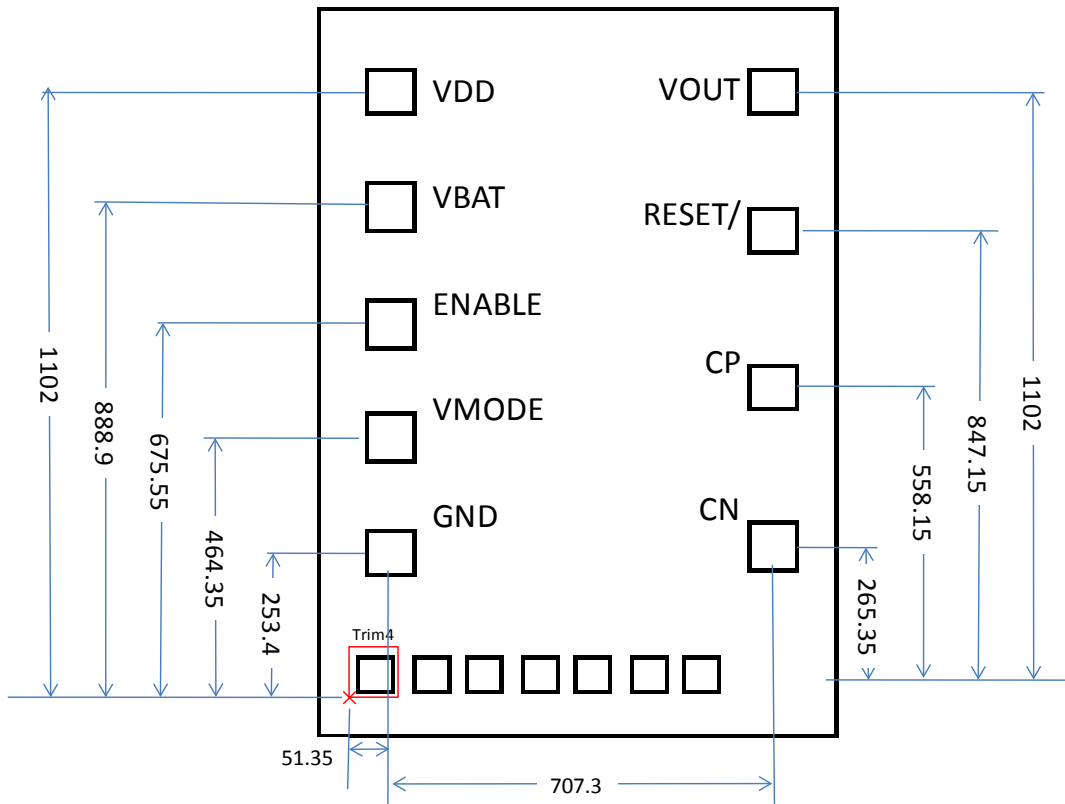

**Notes:**

- 1) All dimensions measured to the center of the respective bond pad and measured relative to the lower left corner of metal-2 on the Trim4 pad as shown below. That Trim4 coordinate is the 0,0 reference point for the data extents of the die. Total die size is 150um larger in x and y as defined by the street width.
- 2) Die size to center of scribe is 960um (x) by 1360um (y).
- 3) Drawing not to scale. All dimensions in microns.

**Ordering Information**

<b>EnerChip CC Part Number</b>	<b>Description</b>	<b>Notes</b>
CBC910-BDC-WP	CBC910 Bare Die	Shipped in Waffle Pack
CBC910-BUC-WP	CBC910 Bare Die Solder Bumped	Shipped in Waffle Pack
CBC910-WAF	CBC910 Bare Die	Shipped as Wafer
CBC910-D3C	CBC910 DFN Package	3mm x 3mm 8L DFN Package

**Disclaimer of Warranties; As Is**

The information provided in this data sheet is provided "As Is" and Cymbet Corporation disclaims all representations or warranties of any kind, express or implied, relating to this data sheet and the Cymbet battery product described herein, including without limitation, the implied warranties of merchantability, fitness for a particular purpose, non-infringement, title, or any warranties arising out of course of dealing, course of performance, or usage of trade. Cymbet battery products are not approved for use in life critical applications. Users shall confirm suitability of the Cymbet battery product in any products or applications in which the Cymbet battery product is adopted for use and are solely responsible for all legal, regulatory, and safety-related requirements concerning their products and applications and any use of the Cymbet battery product described herein in any such product or applications.

**Cymbet, the Cymbet Logo, and EnerChip are Cymbet Corporation Trademarks**