

IG120 Series

High Isolation IGBT Driver DC/DC Converters

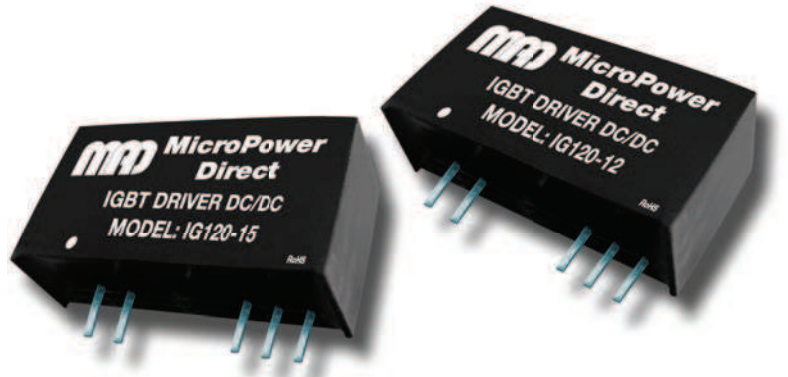

Key Features:

- Operates With xx962 Drivers
- Independent Outputs
- 3,000 VAC Isolation
- Miniature SIP Case
- >3.5 MHour MTBF
- 5 Standard Models
- **LOW COST!!**

Electrical Specifications

Specifications typical @ +25°C, nominal input voltage & rated output current, unless otherwise noted. Specifications subject to change without notice.

Input

Parameter	Conditions	Min.	Typ.	Max.	Units
Supply Voltage Range		See Model Selection Guide			
Input Filter		Internal Capacitor			

Output

Parameter	Conditions	Min.	Typ.	Max.	Units
Line Regulation, See Note 1	For Vin Change of 1%		±1.3	±1.5	%
Ripple & Noise (20 MHz)	IG120-12		100	200	mV P - P
	IG120-12W		100	200	
	IG120-15		80	150	
	IG135-15		50	150	
Efficiency			80		%
	Output Short Circuit, See Note 3		Continuous (Autorecovery)		

General

Parameter	Conditions	Min.	Typ.	Max.	Units
Isolation Voltage	60 Seconds	3,000			VAC
Isolation Resistance			1,000		MΩ
	IG120-12		6.6		pF
Isolation Capacitance, 1 kHz/1V	IG120-12W		10		
	IG120-15		6.6		
	IG135-15		8.0	10	
	IG120-24		6.6		
Switching Frequency			550		kHz

Environmental

Parameter	Conditions	Min.	Typ.	Max.	Units
Operating Temperature Range	Ambient	-40	+25	+85	°C
Storage Temperature Range		-50		+125	°C
Cooling	Free Air Convection				
Humidity	RH, Non-condensing			95	%

Physical

Case Size	0.768 x 0.386 x 0.492 Inches (19.50 x 9.80 x 12.50 mm)				
Case Material	Non-Conductive Black Plastic (UL94-V0)				
Weight	0.195 Oz (5.5g)				

Reliability Specifications

Parameter	Conditions	Min.	Typ.	Max.	Units
MTBF	MIL HDBK 217F, 25°C, Gnd Benign	3.5			MHours

Absolute Maximum Ratings

Parameter	Conditions	Min.	Typ.	Max.	Units
Max Supply Voltage (1 Sec)	IG120-12			13	VDC
	IG120-12W			15	
	IG120-15			16	
	IG135-15			16	
	IG120-24			26	
Lead Temperature	1.5 mm From Case For 10 Sec			300	°C

Caution: Exceeding Absolute Maximum Ratings may damage the module. These are not continuous operating ratings.



MicroPower Direct

292 Page Street
Suite D
Stoughton, MA 02072
USA

T: (781) 344-8226
F: (781) 344-8481
E: sales@micropowerelectronics.com
W: www.micropowerelectronics.com



www.micropowerelectronics.com

Model Number	Input (Supply)		Output 1					Output 2					Output Load Regulation (%)	Maximum Capacitive Load (μF)	Fuse Rating Slow-Blow (mA)
	Voltage (VDC)		Voltage (VDC)			Current (mA Max)	Current (mA, Min)	Voltage (VDC)			Current (mA Max)	Current (mA, Min)			
	Nom.	Range	Min.	Nom.	Max.			Min.	Nom.	Max.					
IG120-12	12	11.6 - 12.4	14.0	15.0	16.0	80.0	0.0	-7.0	-9.0	-10.0	40.0	0.0	12	470	1,000
IG120-12W	12	9.0 - 15.0	14.0	15.0	16.0	100.0	0.0	-7.0	-8.0	-9.0	80.0	0.0	12	470	1,000
IG120-15	15	14.5 - 15.5	14.0	15.0	16.0	80.0	0.0	-7.0	-8.7	-10.0	40.0	0.0	18	470	1,000
IG136-15	15	14.5 - 15.5	16.5	17.0	18.0	80.0	0.0	-7.0	-8.7	-10.0	40.0	0.0	18	470	1,000
IG120-24	24	23.3 - 24.7	14.0	15.0	16.0	80.0	0.0	-7.0	-9.0	-10.0	40.0	0.0	12	470	1,000

The IG120 series is designed to operate with the IGD962 IGBT driver.

Typical Connection

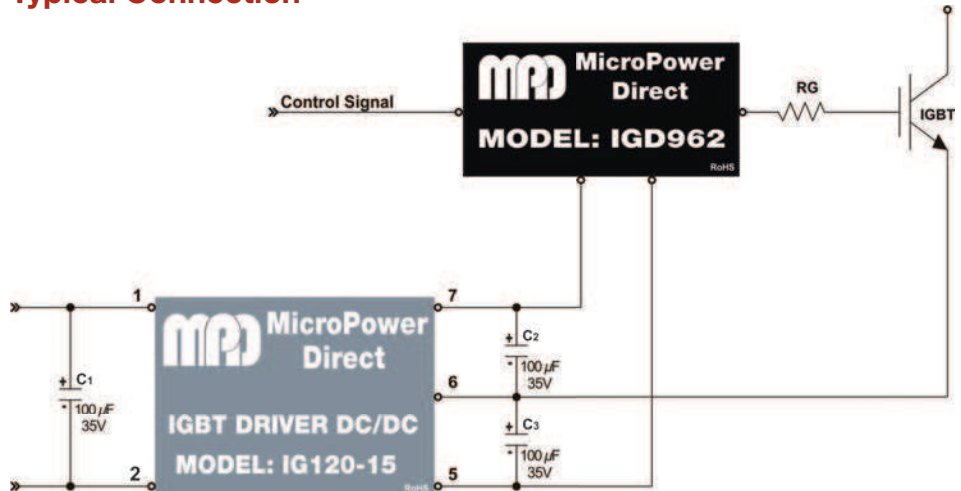

Notes:

1. Line regulation for model IG120-12W is given for a V_{in} change of 25%.
2. Load regulation is measured from 10% load to full load. Load regulation is specified for the primary output (output 1). Load regulation of output 2 may vary slightly.
3. Operation at no-load will not damage these units. However, they may not meet all specifications.
4. If output 2 is not used, it should be left open.
5. A short circuit fault that lasts over 10 minutes could damage the unit due to an over temperature fault.
6. It is recommended that a fuse be used on the input of a power supply for protection. See the Model Selection table above for the correct rating.

Mechanical Dimensions

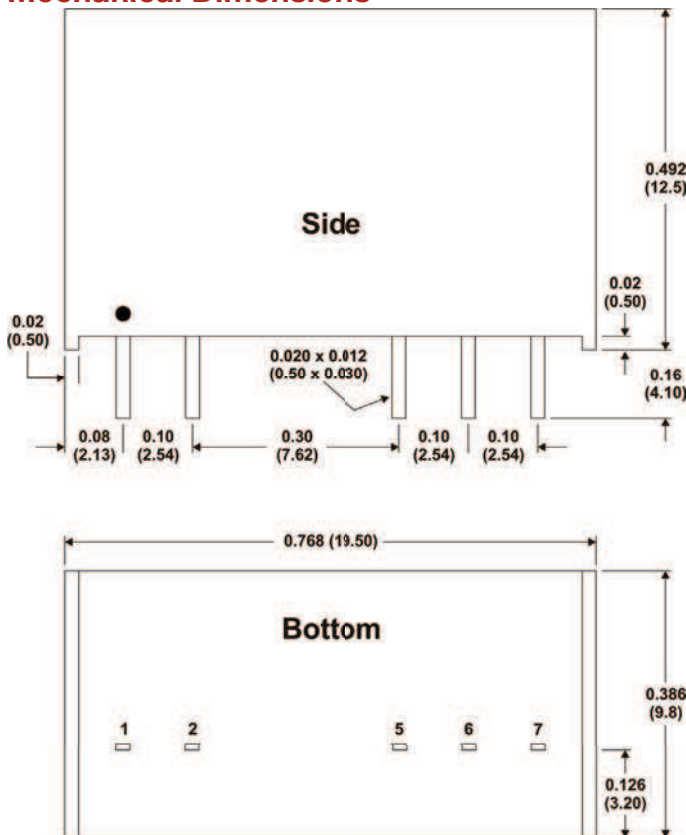

Connection Notes:

1. For model IG120-24, C1 is a 100 μF/65V.
2. Capacitors C1, C2 and C3 should be mounted as close to the unit as possible. To ensure peak gate current, these capacitors should have a low ESR.
3. The trace (or wire) between the DC/DC and the driver circuit should be as short as possible.
4. The average output power of the driver circuit must be lower than output power of the DC/DC.

Pin Connections

Pin	Function
1	+Vin
2	Gnd
5	Vout 2
6	Common
7	Vout 1

Notes:

- All dimensions are typical in inches (mm)
- Tolerance x.xx = ±0.01 (±0.25)
- Pin 1 is marked by a "dot" or indentation on the side of the unit



MicroPower Direct
We Power Your Success - For Less!