

# LD48-XX-XXX

## Compact, Wide Input Constant Current DC/DC LED Drivers

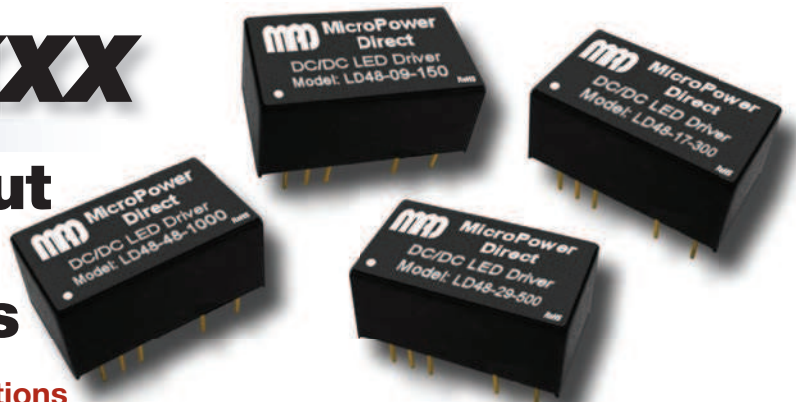

### Key Features:

- Constant Current Output
- Wide 7V to 60V Input Range
- Efficiency to 97%
- Miniature MiniDIP Case
- 300 mA to 1A Output
- Meets EN 60950
- 950 kHrs MTBF
- **Digital & Analog Dimming!**

Models Available  
with Wire Leads  
(IP67 Rated)



### MicroPower Direct

292 Page Street  
Suite D  
Stoughton, MA 02072  
USA

T: (781) 344-8226  
F: (781) 344-8481  
E: sales@micropowerdirect.com  
W: www.micropowerdirect.com



### Electrical Specifications

Specifications typical @ +25°C, nominal input voltage & rated output current, unless otherwise noted. Specifications subject to change without notice.

#### Input

| Parameter           | Conditions         | Min. | Typ. | Max. | Units |
|---------------------|--------------------|------|------|------|-------|
| Input Voltage Range |                    | 7.0  |      | 60.0 | VDC   |
| Max Input Voltage   | 0.5 Sec. Max       |      |      | 65.0 | VDC   |
| Input Filter        | Internal Capacitor |      |      |      |       |

#### Output

| Parameter               | Conditions                        | Min. | Typ. | Max.  | Units |
|-------------------------|-----------------------------------|------|------|-------|-------|
| Output Voltage Range    | V <sub>IN</sub> = 60V             | 2    |      | 57    | VDC   |
| Output Current          | See Model Selection Guide         |      |      |       |       |
| Output Current Accuracy | See Model Selection Guide         |      |      |       |       |
| Output Power            | See Model Selection Guide         |      |      |       |       |
| Efficiency              | See Model Selection Guide         |      |      |       |       |
| Capacitive Load         |                                   |      |      | 470   | μF    |
| Operating Frequency     |                                   | 20   |      | 500   | kHz   |
| Ripple & Noise (20 MHz) | See Model Selection Guide         |      |      |       |       |
| Temperature Coefficient |                                   |      |      | ±0.03 | %/°C  |
| Thermal Impedance       | Natural Convection                |      |      | +30   | °C/W  |
| Output Short Circuit    | Regulated At Rated Output Current |      |      |       |       |

#### Environmental

| Parameter                   | Conditions                  | Min. | Typ. | Max. | Units |
|-----------------------------|-----------------------------|------|------|------|-------|
| Operating Temperature Range | Ambient                     | -40  | +25  | +85  | °C    |
|                             | Case                        |      |      | +110 |       |
| Storage Temperature Range   |                             | -40  |      | +125 | °C    |
| Cooling                     | Free Air Convection         |      |      |      |       |
| Humidity                    | RH, Non-condensing          |      |      | 95   | %     |
| Lead Temperature (Solder)   | 1.5 mm From Case For 10 Sec |      |      | 260  | °C    |

#### Physical

|               |  |  |  |  |  |
|---------------|--|--|--|--|--|
| Case Size     | 1.25 x 0.80 x 0.49 Inches (31.75 x 20.32 x 12.45 mm) |  |  |  |  |
| Case Material | Non-Conductive Black Plastic (UL94-V0)               |  |  |  |  |
| Weight        | 0.622 Oz (17.7g)                                     |  |  |  |  |

#### Remote On/Off Control

| Parameter                               | Conditions               | Min.                                    | Typ. | Max. | Units |
|---|--------------------------|---|------|------|-------|
| DC/DC On                                |                          | Open or 0.3V < V <sub>ADJ</sub> < 1.25V |      |      |       |
| DC/DC Off                               |                          | V <sub>ADJ</sub> < 0.15V                |      |      |       |
| Remote Pin Drive Current                | V <sub>ADJ</sub> = 1.25V |   |      | 1    | mA    |
| Quiescent Input Current (Shutdown Mode) | V <sub>IN</sub> = 60V    |   |      | 100  | μA    |

#### PWM Dimming

| Parameter           | Conditions          | Min. | Typ. | Max. | Units |
|---------------------|---------------------|------|------|------|-------|
| Operation Frequency | Recommended Maximum |      |      | 1.0  | kHz   |
| Switch On Time      |                     | 200  |      |      | nS    |
| Switch Off Time     |                     | 200  |      |      | nS    |

#### Analog Dimming

| Parameter                    | Conditions                        | Min. | Typ. | Max. | Units |
|------------------------------|-----------------------------------|------|------|------|-------|
| Input Voltage Range          | At V <sub>ADJ</sub> Input (Pin 4) | 0.3  |      | 1.25 | VDC   |
| Output Current Adjustment    |                                   | 25   |      | 100  | %     |
| Control Voltage Range Limits | On                                | 0.20 |      | 0.30 | VDC   |
|                              | Off                               | 0.15 |      | 0.25 |       |
| Drive Current                | V <sub>ADJ</sub> = 1.25V          |      |      | 1.0  | mA    |

#### EMC Compliance

|  |                    |                          |  |  |
|--|--------------------|--------------------------|--|--|
| EMI/RFI                                    | Radiated/Conducted | EN 55015 (CISPR22)       |  |  |
| Electrostatic Discharge (ESD)              | Class A            | IEC/EN 61000-4-2, -6, -8 |  |  |
| RF Field Susceptibility                    | Class A            | IEC/EN 61000-4-3         |  |  |
| Electrical Fast Transients/Bursts On Mains | Class A            | IEC/EN 61000-4-4         |  |  |
| EMS Immunity                               |                    | EN61547                  |  |  |

#### Reliability Specifications

| Parameter | Conditions                      | Min. | Typ. | Max. | Units  |
|-----------|---------------------------------|------|------|------|--------|
| MTBF      | MIL HDBK 217F, 25°C, Gnd Benign | 950  |      |      | kHours |

[www.micropowerdirect.com](http://www.micropowerdirect.com)

| Model Number | Input         |               | Output   |              | Maximum Power (W) | Ripple & Noise (mV P-P, Max) | Efficiency (% Typ) |
|--------------|---------------|---------------|----------|--------------|-------------------|------------------------------|--------------------|
|              | Voltage (VDC) | Voltage (VDC) | Current  |              |                   |                              |                    |
|              | Range         | Range         | Max (mA) | Accuracy (%) |                   |                              |                    |
| LD48-09-150  | 7.0 - 60.0    | 2.0 - 57.0    | 150      | ±8           | 9                 | 150                          | 97                 |
| LD48-14-250  | 7.0 - 60.0    | 2.0 - 57.0    | 250      | ±7           | 14                | 200                          | 97                 |
| LD48-17-300  | 7.0 - 60.0    | 2.0 - 57.0    | 300      | ±6           | 17                | 250                          | 97                 |
| LD48-20-350  | 7.0 - 60.0    | 2.0 - 57.0    | 350      | ±5           | 20                | 300                          | 97                 |
| LD48-29-500  | 7.0 - 60.0    | 2.0 - 57.0    | 500      | ±5           | 29                | 400                          | 97                 |
| LD48-34-600  | 7.0 - 60.0    | 2.0 - 57.0    | 600      | ±5           | 34                | 450                          | 97                 |
| LD48-40-700  | 7.0 - 60.0    | 2.0 - 57.0    | 700      | ±5           | 40                | 500                          | 97                 |
| LD48-48-1000 | 7.0 - 60.0    | 2.0 - 57.0    | 1000     | ±5           | 48                | 800                          | 97                 |

**Notes:**

1. A reversed power source could damage the unit.
2. No connection should be made between input ground and the output.
3. These are step-down devices, the maximum output open voltage is equal to the input voltage.
4. The  $V_{ADJ}$  input should be left open if not used. Grounding  $V_{ADJ}$  will shut the unit down. Connecting  $V_{ADJ}$  to  $V_{IN}$  may damage the unit.
5. Exceeding the specified maximum output power could cause damage to the unit.

**Typical Connection: DC/DC Input**

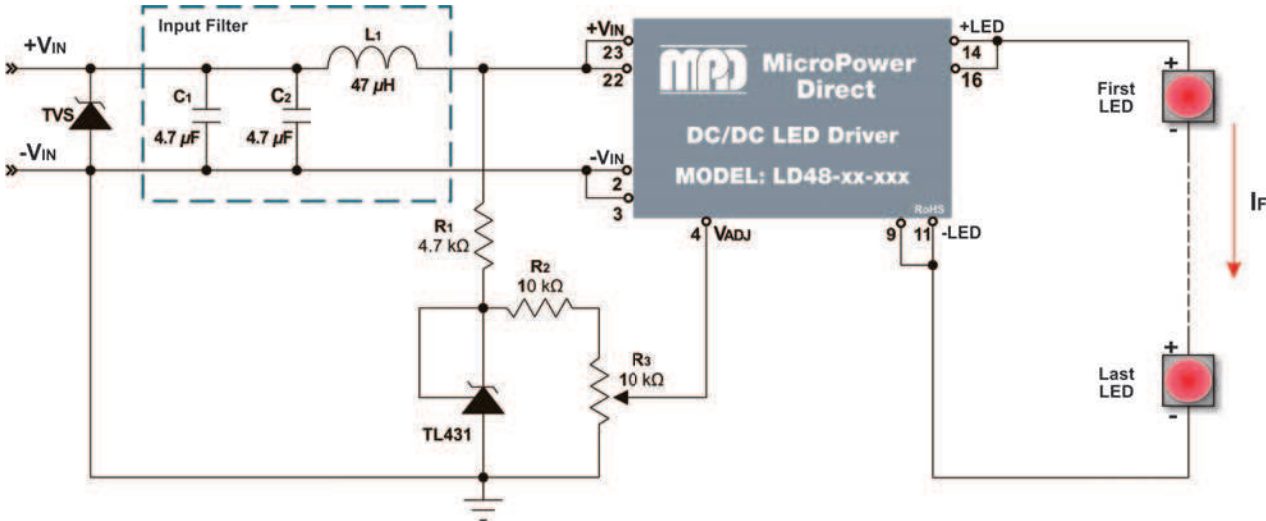

**Connection Notes:**

To comply with EN61000-4-5, a TVS should be installed before the input filter components. A 3.0SMCJ48A or SMCJ48A is recommended. The TVS max clamping voltage (@max peak pulse current Ic) must be  $\leq \pm 60V$ . This will prevent any surge from exceeding the maximum input of the driver (65 VDC). Exceeding the maximum input rating could damage the driver. The filter shown (C1, C2 and L1) will help to meet conducted emission requirements. With the addition of the filter, the unit should meet the levels of EN 55015.

**Typical Connection: AC/DC Input**

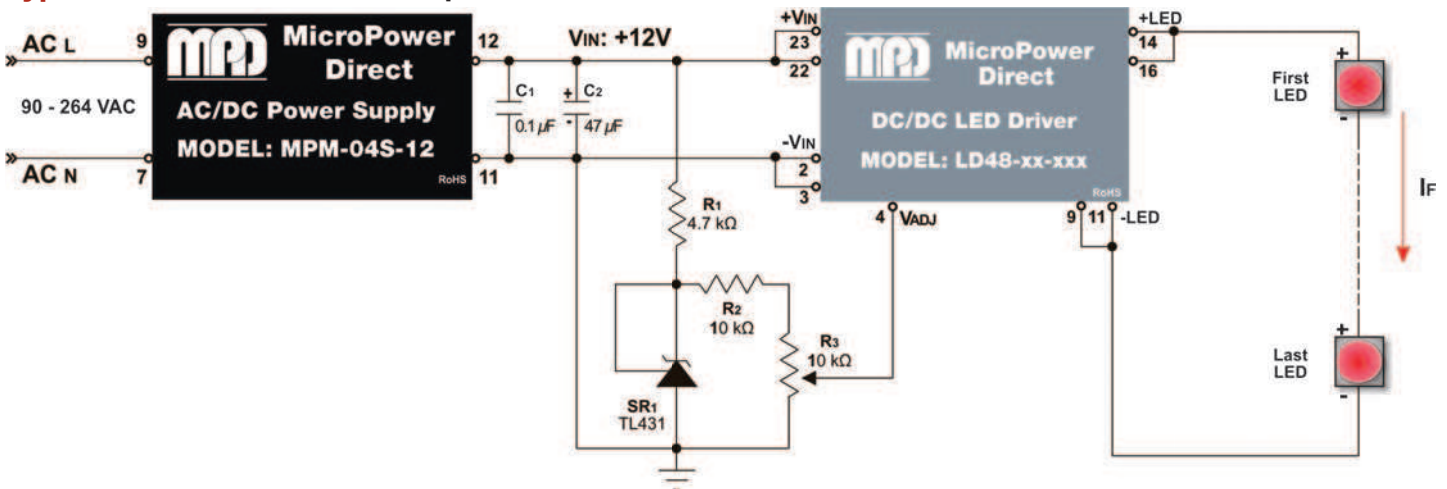

**Connection Notes:**

This is a distributed (or two-stage) AC connection. In this configuration, the AC line in (90 to 264 VAC) is connected to the **MPM-04S-12**, a miniature 4W AC/DC power supply. The **MPM-04S-12** provides a tightly regulated 12 VDC output at 333 mA. The 12 VDC output powers the LED driver.

The two stage approach can simplify the safety approval process (most AC/DC power supplies on the market are approved to EN 60950) and may increase design flexibility. Besides the output power, other specifications to consider when selecting the input AC/DC supply would include input range, safety approvals, PFC rating (which may be needed for various system energy ratings) and operating temperature range.

**Note: The output current adjustment circuit shown in both connection diagrams is discussed on page 4.**



## PWM Output Current Control

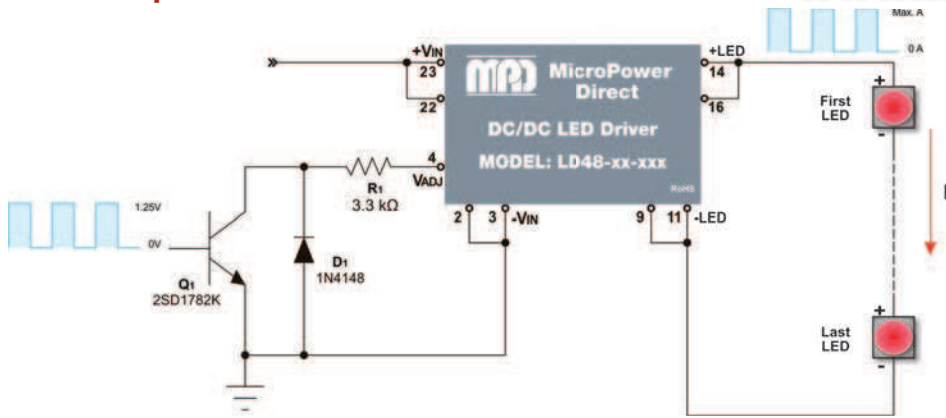

An LED operates at its maximum efficiency when operated at the rated drive current specified by the manufacturer. Operating an LED at lower than its rated forward current not only decreases the system efficiency; but may cause color (or wavelength) shifting. In illumination applications, this could cause visible changes to lighting.

A preferred method is using pulse width modulation (PWM). As shown at left, the output current is adjusted by applying a PWM signal to the VADJ input. By varying the signal duty cycle the average output current is adjusted up or down. To avoid visible flicker, the PWM signal should be greater than 100 Hz.

For duty cycles (DPWM) between 0 and 1, the output current is derived by the formula:

$$I_{NOM} = I_{MAX} \times D_{PWM}$$

## PWM Control Signals

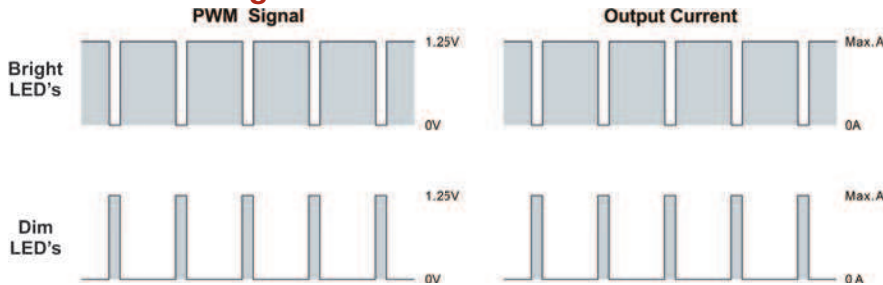

The VADJ input may be driven via an open collector transistor (as shown). The diode and resistor suppress high amplitude negative spikes that may be caused by the drain-source capacitance of the transistor. Negative spikes on the control input of the unit could cause errors in output current or erratic operation.

The VADJ input can also be driven by the open drain output of a microcontroller. Again, any high amplitude negative spikes that may be caused by the drain-source capacitance of the FET must be suppressed.

## PWM Dimming Application

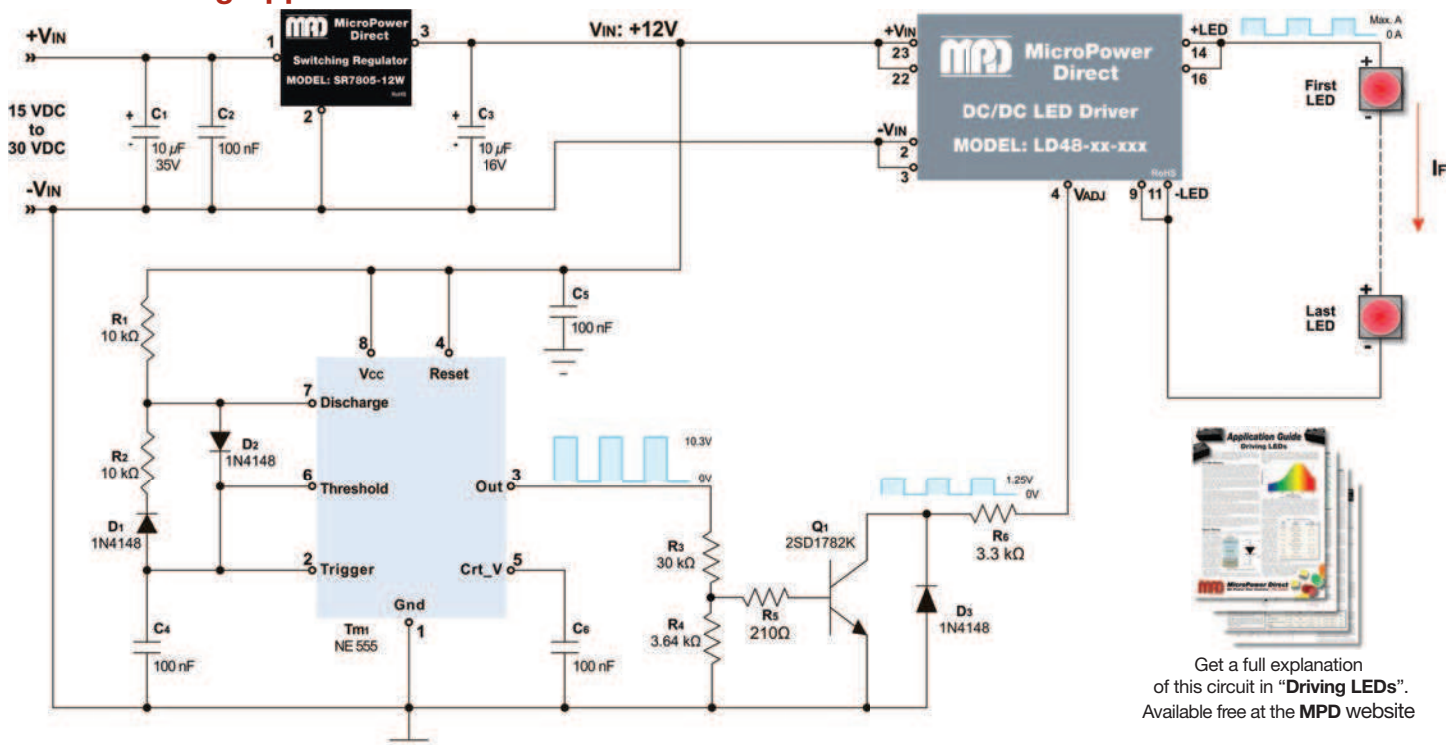

Get a full explanation of this circuit in "Driving LEDs". Available free at the MPD website

A simple method of achieving digital (or PWM) dimming is by using a 555 timer to apply a series of pulses to the VADJ input, as illustrated above. The 555 operates over a supply voltage range of 4.5 VDC to 15VDC. Here it is connected to the 12 VDC output of the SR7805 switching regulator (this is also the VIN of the LED driver). Care should be taken to minimize ripple at the Vcc input. Excess ripple could cause timing errors.

The timer is connected for astable (free run) operation. The frequency is set by R1, R2 and C4. The timing capacitor (C4) charges through R1 and D2. When it reaches the level of 2/3 Vcc, the discharge pin (pin 7) goes low and C4 will discharge through D1 and R2 to the internal discharge transistor. When the C4 voltage drops to 1/3 Vcc, the discharge pin goes high and C4 begins to charge

again. The formulas for calculating the frequency and duty cycle are included in the MPD application note "Driving LEDs".

The diodes (D1 and D2) allow duty cycles below 50% to be set. Diode D1 bypasses R2 while C4 is charging. Diode D2 is optional (but recommended), essentially blocking R2 during the charge period. Theoretically, this circuit will allow for duty cycles over a range of approximately 5% to 95%. If manual adjustment is desired, a potentiometer may be substituted for R2 (with some adjustment of the circuit).

The size of C4 is generally not critical, but it should be as low leakage as possible. In order to avoid excessive current flow through the internal discharge transistor, it is recommended that R1 be at least 5 kΩ.

The output current of the unit can also be set by adjusting the voltage level on the V<sub>ADJ</sub> input to a value between 0.3V to 1.25V (I<sub>OUT</sub> will vary from 25% to 100% of rated output current). Care must be taken not to exceed 1.25V on this input, or the driver may be damaged.

A simple analog circuit using two low cost, switching regulators is shown at left. Working from inputs that can range from 15 to 32 VDC, the top regulator (SR1) keeps the input to the LED driver at 12 VDC.

The other regulator (SR2), driven off the same input line maintains the control voltage (for the V<sub>ADJ</sub> input) at 5 VDC. The resistor network of R<sub>1</sub> and R<sub>2</sub> can now be used to set the output current level of the LED driver. This level is equal to:

$$V_{ADJ} = \frac{R_2}{R_1 + R_2} \times V_{CTRL}$$

In the second circuit, the 5 VDC regulator (SR2) is replaced by the shunt regulator (D1) circuit connected in parallel with the resistor network. The regulator will maintain the voltage across R<sub>2</sub> and R<sub>3</sub> at 2.5 VDC, insuring that the 1.25 VDC limit on the V<sub>ADJ</sub> pin will not be exceeded. This circuit will work for inputs between 7VDC and approximately 36 VDC. For inputs between 36 VDC and 60 VDC, a zener diode (D2) has been added.

When using the analog control input, the nominal output current is equal to:

$$I_{NOM} = I_{MAX} \times \frac{V_{ADJ}}{1.25}$$

The V<sub>ADJ</sub> input should be left open if not used. Grounding V<sub>ADJ</sub> will shut the unit down. Connecting V<sub>ADJ</sub> to directly to +V<sub>IN</sub> may damage the unit.

### Analog Output Current Control

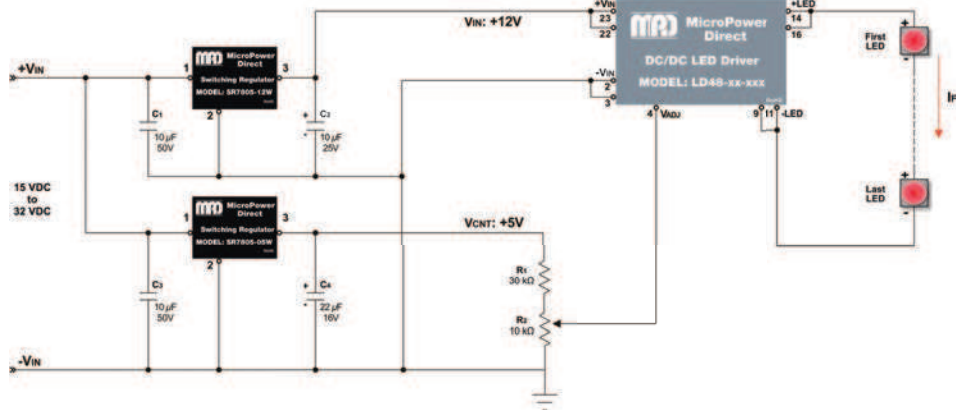

### Analog Output Current Control (7 - 36 VDC IN)

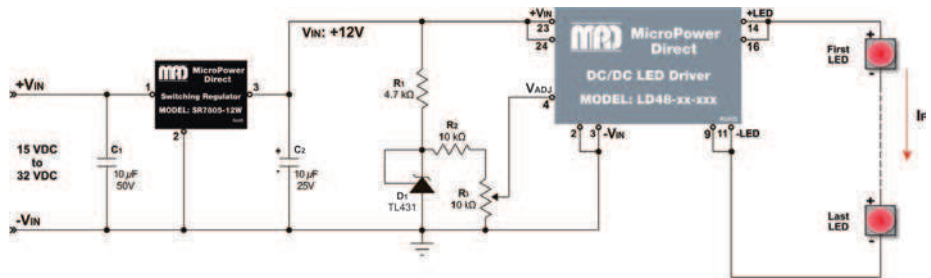

### Analog Output Current Control (36 - 60 VDC IN)

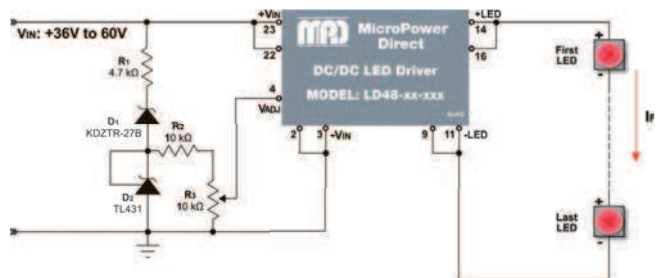

### Mechanical Dimensions

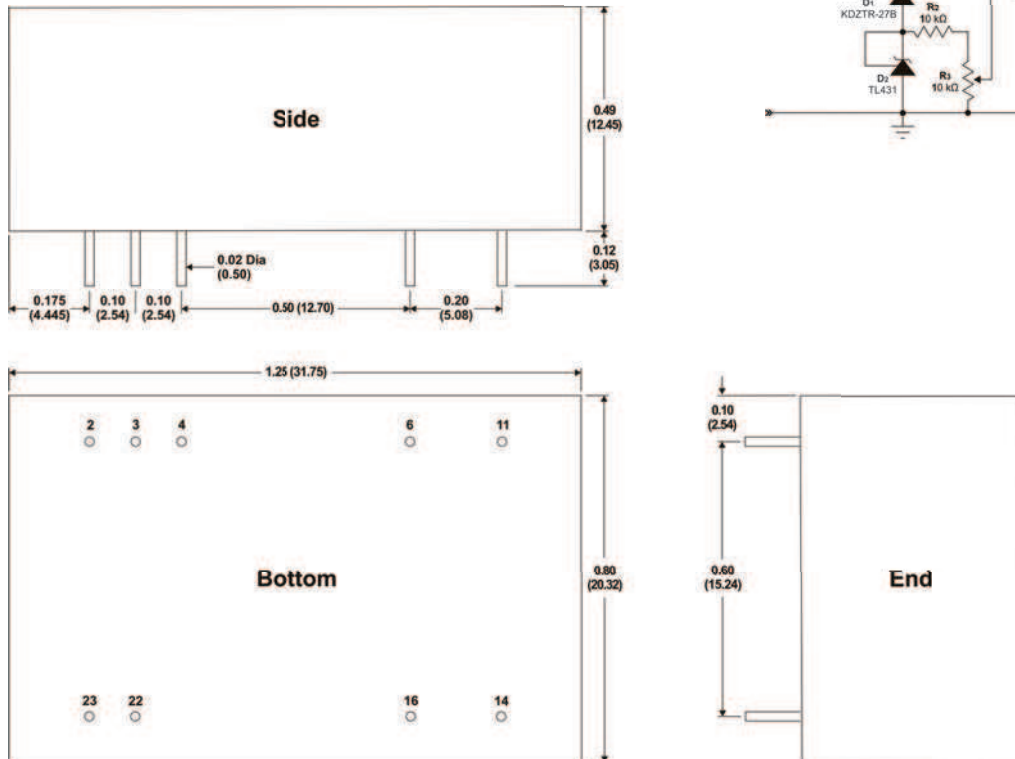

### Pin Connections

| Pin | Function                     |
|-----|------------------------------|
| 2   | -V <sub>IN</sub> -DC Supply  |
| 3   | -V <sub>IN</sub> -DC Supply  |
| 4   | V <sub>ADJ</sub> PWM, On/Off |
| 9   | -LED LED Cathode Conn.       |
| 11  | -LED LED Cathode Conn.       |
| 14  | +LED LED Anode Conn.         |
| 16  | +LED LED Anode Conn.         |
| 22  | +V <sub>IN</sub> +DC Supply  |
| 23  | +V <sub>IN</sub> +DC Supply  |

### Notes:

- All dimensions are typical in inches (mm)
- Tolerance x.xx = ±0.02 (±0.50)
- Pin 1 is marked by a "dot" or indentation on the top of the unit



**MicroPower Direct**  
We Power Your Success - For Less!