

# LD24-XX-XXX

## Compact, Wide Input Constant Current DC/DC LED Drivers



### Key Features:

- Constant Current Output
- Wide 7V to 30V Input Range
- Efficiency to 95%
- Miniature MiniDIP Case
- 150 mA to 1A Output
- Meets EN 60950
- 1.6 Mhrs MTBF
- **Digital & Analog Dimming!**

Models Available  
with Wire Leads  
(IP67 Rated)



### MicroPower Direct

292 Page Street  
Suite D  
Stoughton, MA 02072  
USA

T: (781) 344-8226  
F: (781) 344-8481  
E: sales@micropowerdirect.com  
W: www.micropowerdirect.com



### Electrical Specifications

Specifications typical @ +25°C, nominal input voltage & rated output current, unless otherwise noted. Specifications subject to change without notice.

#### Input

Parameter	Conditions	Min.	Typ.	Max.	Units
Input Voltage Range		7.0	24	30.0	VDC
Max Input Voltage	0.5 Sec. Max			40.0	VDC
Input Filter	Internal Capacitor				

#### Output

Parameter	Conditions	Min.	Typ.	Max.	Units
Output Voltage Range	V <sub>IN</sub> = 30V	2		28	VDC
Output Current	See Model Selection Guide				
Output Current Accuracy	See Model Selection Guide				
Output Power	See Model Selection Guide				
Efficiency	See Model Selection Guide				
Capacitive Load				47	μF
Operating Frequency		40		380	kHz
Ripple & Noise (20 MHz)	See Model Selection Guide				
Temperature Coefficient			±0.03	±0.08	%/°C
Thermal Impedance	Natural Convection			+50	°C/W
Output Short Circuit	Regulated At Rated Output Current				

#### Environmental

Parameter	Conditions	Min.	Typ.	Max.	Units
Operating Temperature Range	Ambient	-40	+25	+85	°C
	Case			+105	
Storage Temperature Range		-40		+125	°C
Cooling	Free Air Convection				
Humidity	RH, Non-condensing			95	%
Lead Temperature (Solder)	1.5 mm From Case For 10 Sec			260	°C

#### Remote On/Off Control

Parameter	Conditions	Min.	Typ.	Max.	Units
DC/DC On		Open or 0.3V < V <sub>ADJ</sub> < 1.25V			
DC/DC Off		V <sub>ADJ</sub> < 0.15V			
Remote Pin Drive Current	V <sub>ADJ</sub> = 1.25V			1	mA
Quiescent Input Current (Shutdown Mode)	V <sub>IN</sub> = 30V			25	μA

#### PWM Dimming

Parameter	Conditions	Min.	Typ.	Max.	Units
Operation Frequency	Recommended Maximum			1.0	kHz
Switch On Time		200			nS
Switch Off Time		200			nS
Output Current Adjustment		0.0		100	%

#### Analog Dimming

Parameter	Conditions	Min.	Typ.	Max.	Units
Input Voltage Range	At V <sub>ADJ</sub> Input	0.0		1.25	VDC
Output Current Adjustment		25		100	%
Control Voltage Range Limits	On	0.30		1.25	VDC
	Off	0.0		0.15	
Drive Current	V <sub>ADJ</sub> = 1.25V			1.0	mA

#### EMC Compliance

EMI/RFI	Radiated/Conducted	EN 55015 (CISPR22)		
Electrostatic Discharge (ESD)	Class A	IEC/EN 61000-4-2, -6, -8		
RF Field Susceptibility	Class A	IEC/EN 61000-4-3		
Electrical Fast Transients/Bursts On Mains	Class A	IEC/EN 61000-4-4		
EMS Immunity		EN61547		

#### Reliability Specifications

Parameter	Conditions	Min.	Typ.	Max.	Units
MTBF	MIL HDBK 217F, 25°C, Gnd Benign	1.6			MHours

[www.micropowerdirect.com](http://www.micropowerdirect.com)

Model Number	Input		Output		Maximum Power (W)	Ripple & Noise (mV P-P, Max)	Efficiency (% Max)	Package
	Voltage (VDC)	Voltage (VDC)	Current					
	Range	Range	Max (mA)	Accuracy (%)				
LD24-04-150	7.0 - 30.0	2.0 - 28.0	150	±10	4.2	200	95	14 -Pin DIP
LD24-07-250	7.0 - 30.0	2.0 - 28.0	250	±8	7	200	95	14 -Pin DIP
LD24-08-300	7.0 - 30.0	2.0 - 28.0	300	±6	8	200	95	14 -Pin DIP
LD24-08-350	7.0 - 30.0	2.0 - 28.0	350	±5	8	200	95	14 -Pin DIP
LD24-14-500	7.0 - 30.0	2.0 - 28.0	500	±6	14	250	95	16 -Pin DIP
LD24-17-600	7.0 - 30.0	2.0 - 28.0	600	±7	17	250	95	16 -Pin DIP
LD24-20-700	7.0 - 30.0	2.0 - 28.0	700	±7	20	250	95	16 -Pin DIP
LD24-24-1000	7.0 - 30.0	2.0 - 28.0	1,000	±7	24	300	95	16 -Pin DIP

Notes:

1. A reversed power source could damage the unit.
2. No connection should be made between input ground and the output.
3. These are step-down devices, the maximum output open voltage is equal to the input voltage.
4. The V<sub>ADJ</sub> input should be left open if not used. Grounding V<sub>ADJ</sub> will shut the unit down. Connecting V<sub>ADJ</sub> to V<sub>IN</sub> may damage the unit.
5. Exceeding the specified maximum output power could cause damage to the unit.

Typical Connection: DC/DC Input

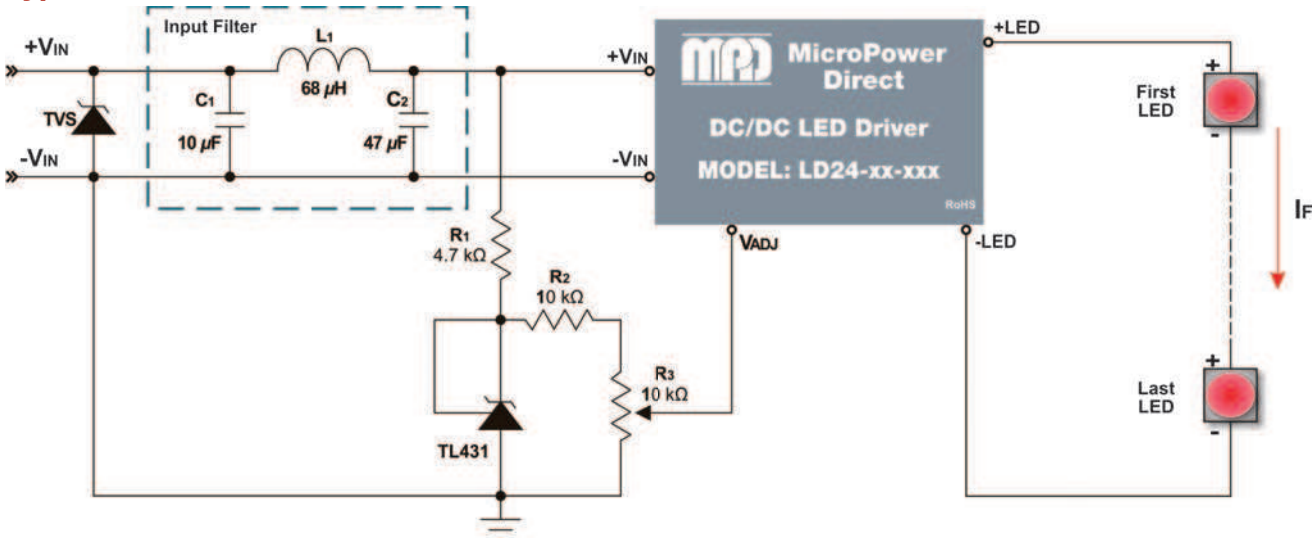

Connection Notes:

To comply with EN61000-4-5, a TVS should be installed before the input filter components. A 3.0SMCJ24A or SMCJ24A is recommended. The TVS max clamping voltage (@max peak pulse current I<sub>p</sub>) must be ≤ ±40V. Exceeding the maximum input rating could damage the driver.

The filter shown (C1, C2 and L1) will help to meet conducted emission requirements. With the addition of the filter, the unit should meet the levels of EN 55015.

Typical Connection: AC/DC Input

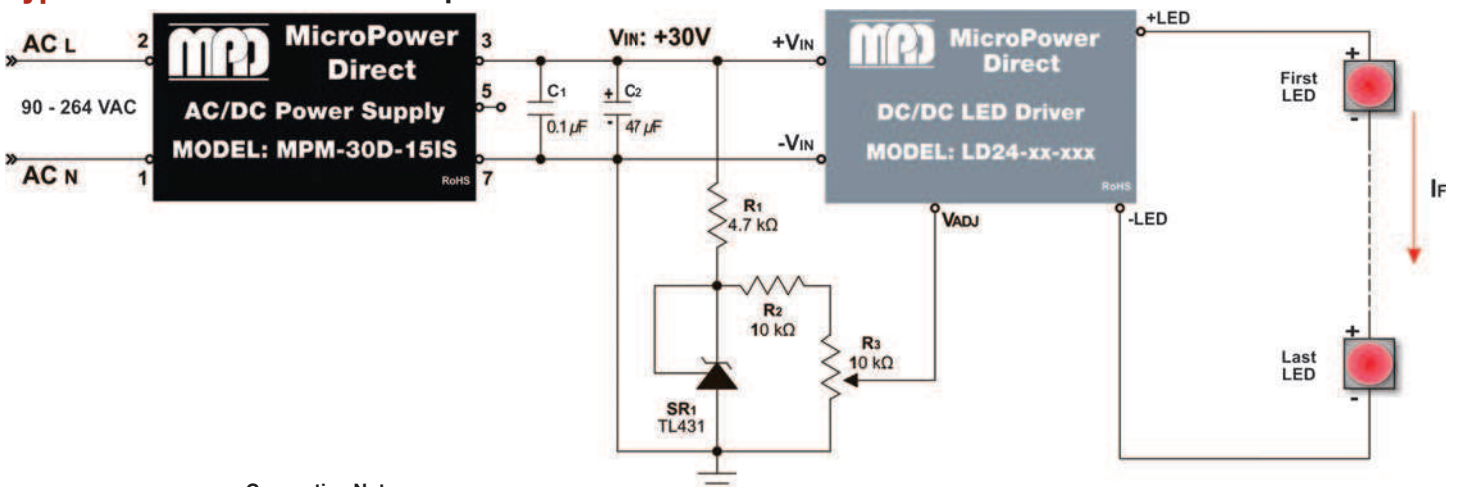

Connection Notes:

This is a distributed (or two-stage) AC connection. In this configuration, the AC line in (90 to 264 VAC) is connected to the MPM-30D-15IS, a compact 30W AC/DC power supply. The MPM-30D-15IS is connected across its ±15 VDC outputs to provide a tightly regulated 30 VDC output at 1A. The 30 VDC output powers the LED driver.

The two stage approach can simplify the safety approval process (most AC/DC power supplies on the market are approved to EN 60950) and may increase design flexibility. Besides the output power, other specifications to consider when selecting the input AC/DC supply would include input range, safety approvals, PFC rating (which may be needed for various system energy ratings) and operating temperature range.

Note: The output current adjustment circuit shown in both connection diagrams is discussed on page 4.



## PWM Output Current Control

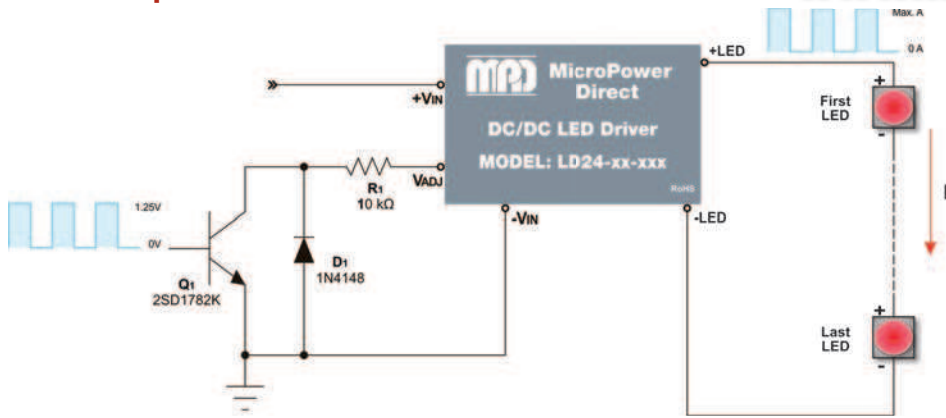

An LED operates at its maximum efficiency when operated at the rated drive current specified by the manufacturer. Operating an LED at lower than its rated forward current not only decreases the system efficiency; but may cause color (or wavelength) shifting. In illumination applications, this could cause visible changes to lighting.

A preferred method is using pulse width modulation (PWM). As shown at left, the output current is adjusted by applying a PWM signal to the VADJ input. By varying the signal duty cycle the average output current is adjusted up or down. To avoid visible flicker, the PWM signal should be greater than 100 Hz.

For duty cycles (DPWM) between 0 and 1, the output current is derived by the formula:

$$I_{NOM} = I_{MAX} \times D_{PWM}$$

The VADJ input may be driven via an open collector transistor (as shown). The diode and resistor suppress high amplitude negative spikes that may be caused by the drain-source capacitance of the transistor. Negative spikes on the control input of the unit could cause errors in output current or erratic operation.

The VADJ input can also be driven by the open drain output of a microcontroller. Again, any high amplitude negative spikes that may be caused by the drain-source capacitance of the FET must be suppressed.

## PWM Control Signals

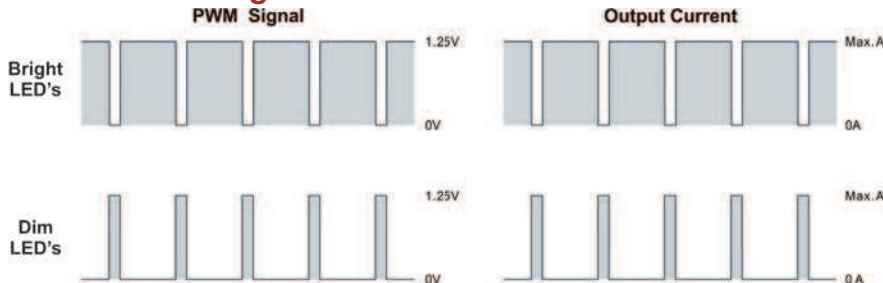

## PWM Dimming Application

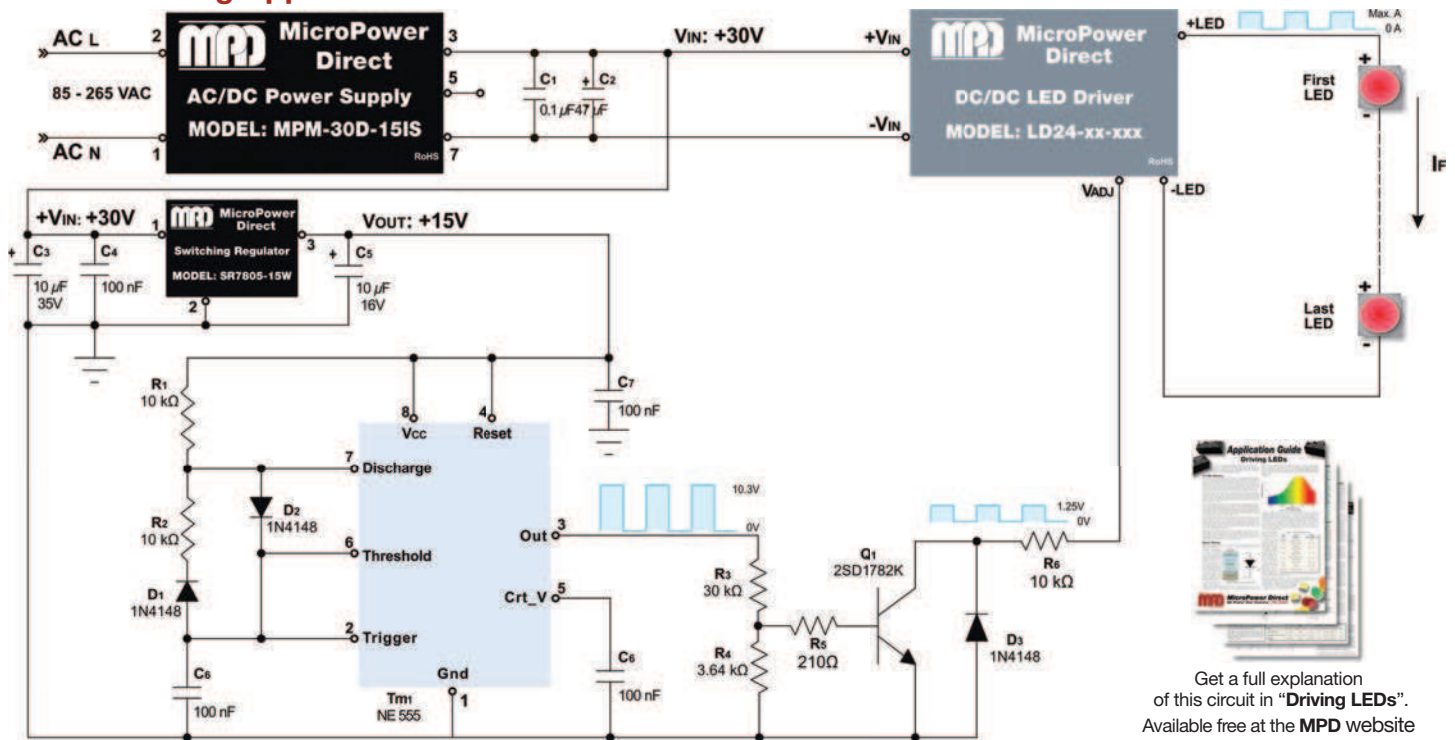

Get a full explanation of this circuit in "Driving LEDs". Available free at the MPD website

A simple method of achieving digital (or PWM) dimming is by using a 555 timer to apply a series of pulses to the VADJ input, as illustrated above. Again, we are powering the LED driver with the MPM-30D-15IS AC power supply.

The 555 operates over a supply voltage range of 4.5 VDC to 18VDC. Here it is connected to the 15 VDC output of the SR7805 switching regulator (also driven by the MPM-20S-24EPB). Care should be taken to minimize ripple at the Vcc input. Excess ripple could cause timing errors.

The timer is connected for astable (free run) operation. The frequency is set by R1, R2 and C6. The timing capacitor (C6) charges through R1 and D2. When it reaches the level of 2/3 Vcc, the discharge pin (pin 7) goes low and C6 will discharge through D1 and R2 to the internal discharge transistor. When the C6

voltage drops to 1/3 Vcc, the discharge pin goes high and C6 begins to charge again. The formulas for calculating the frequency and duty cycle are included in the MPD application note "Driving LEDs".

The diodes (D1 and D2) allow duty cycles below 50% to be set. Diode D1 bypasses R2 while C6 is charging. Diode D2 is optional (but recommended), essentially blocking R2 during the charge period. Theoretically, this circuit will allow for duty cycles over a range of about 5% to 95%. If manual adjustment is desired, a potentiometer may be substituted for R2 (with some adjustment of the circuit).

The size of C6 is generally not critical, but it should be as low leakage as possible. In order to avoid excessive current flow through the internal discharge transistor, it is recommended that R1 be at least 5 kΩ.

The output current of the unit can also be set by adjusting the voltage level on the V<sub>ADJ</sub> input to a value between 0.3V to 1.25V (I<sub>OUT</sub> will vary from 25% to 100% of rated output current). Care must be taken not to exceed 1.25V on this input, or the driver may be damaged.

### Analog Output Current Control

The simple analog circuit at left uses the **F2506RW**, a 30W, dual 15V output DC/DC converter. Operating from an input line of 12 VDC, the converter sets the input to the LED driver at 30 VDC.

The POL regulator, driven off the same input line maintains the control voltage (for the V<sub>ADJ</sub> input) at 5 VDC. The resistor network of R<sub>1</sub> and R<sub>2</sub> can now be used to set the output current level of the LED driver. This level is equal to:

$$V_{ADJ} = \frac{R_2}{R_1 + R_2} \times V_{CTRL}$$

In the second circuit, the input DC/DC has been changed to the **F2506RU**. The 4:1 input of the converter allows for wider input bus levels (in this case 24 VDC). The POL regulator is also replaced by the shunt regulator (D<sub>1</sub>). The regulator, connected in parallel with the resistor network, will maintain the voltage across R<sub>2</sub> and R<sub>3</sub> at 2.5 VDC, insuring that the 1.25 VDC limit on the V<sub>ADJ</sub> pin will not be exceeded.

When using the analog control input, the nominal output current is equal to:

$$I_{NOM} = I_{MAX} \times \frac{V_{ADJ}}{1.25}$$

The V<sub>ADJ</sub> input should be left open if not used. Grounding V<sub>ADJ</sub> will shut the unit down. Connecting V<sub>ADJ</sub> to directly to +V<sub>IN</sub> may damage the unit.

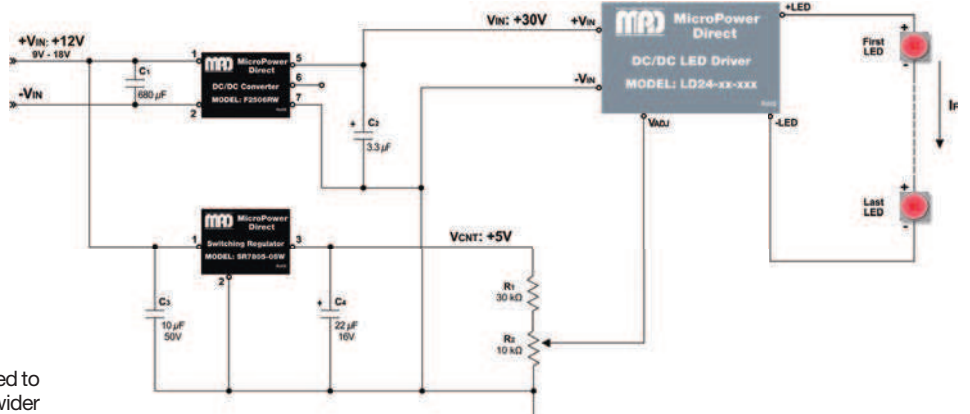

### Analog Output Current Control (7 - 30 VDC IN)

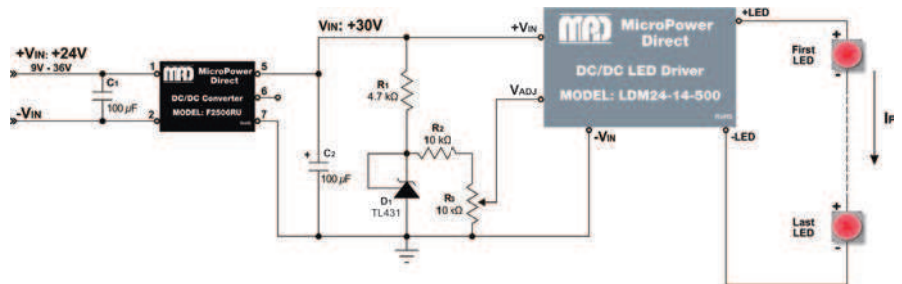

### Mechanical Dimensions - 16 Pin DIP

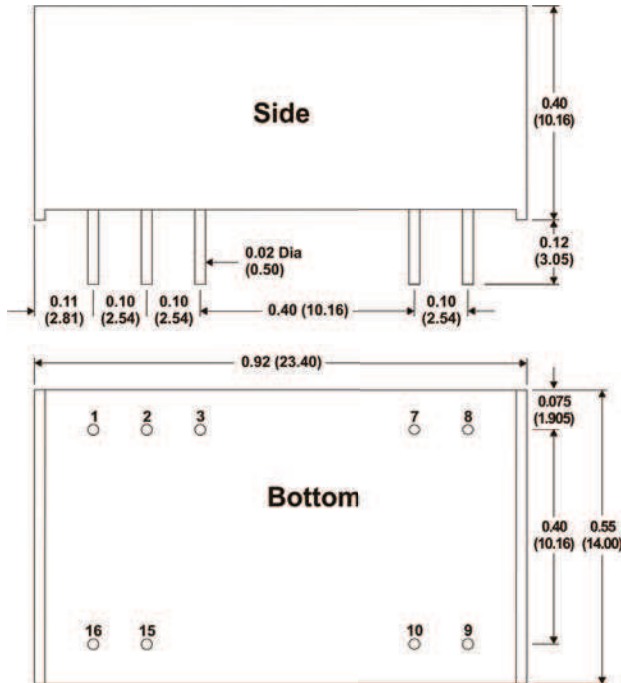

### Mechanical Dimensions - 14 Pin DIP

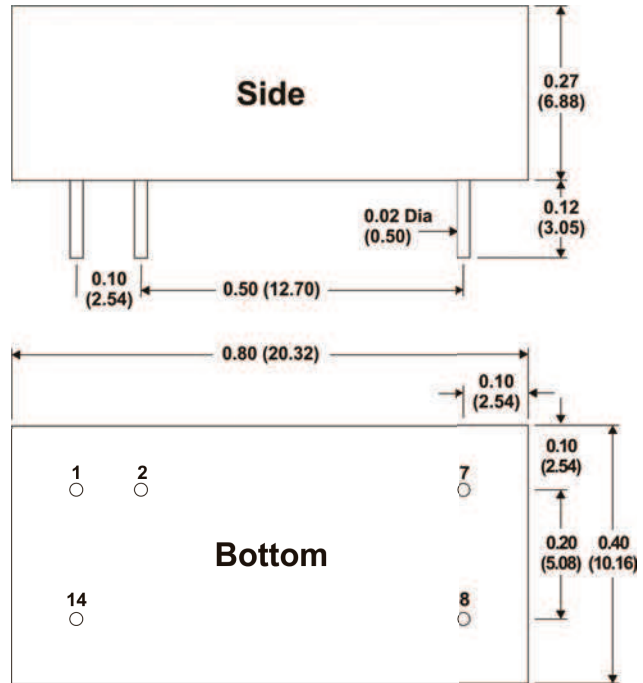

### Pin Connections - 16 Pin DIP

Pin	Function	Pin	Function
1	-V <sub>IN</sub> -DC Supply	9	+LED LED Anode Conn.
2	-V <sub>IN</sub> -DC Supply	10	+LED LED Anode Conn.
3	V <sub>ADJ</sub> PWM, On/Off	15	+V <sub>IN</sub> +DC Supply
7	-LED LED Cathode Conn.	16	+V <sub>IN</sub> +DC Supply
8	-LED LED Cathode Conn.		

### Pin Connections - 14 Pin DIP

Pin	Function	Pin	Function
1	-V <sub>IN</sub> -DC Supply	8	+LED LED Anode Conn.
2	V <sub>ADJ</sub> PWM, On/Off	14	+V <sub>IN</sub> +DC Supply
7	-LED LED Cathode Conn.		

#### Notes:

- All dimensions are typical in inches (mm)
- Tolerance x.xx = ±0.02 (±0.50)
- Pin 1 is marked by a "dot" or indentation on the top of the unit



**MicroPower Direct**  
We Power Your Success - For Less!