

# LDM12-XX-XXX

## Miniature, Wide Input Constant Current DC/DC LED Drivers

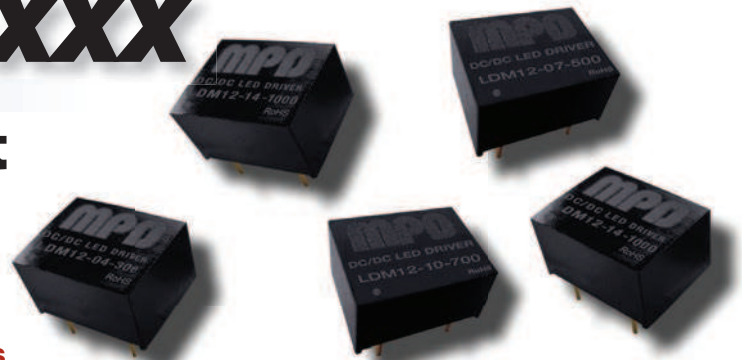

### Key Features:

- Constant Current Output
- Wide 7V to 16V Input Range
- 93% Efficiency
- Miniature MiniDIP Case
- 300 mA to 1A Output
- Meets EN 60950
- 3.3 MHrs MTBF
- **Digital & Analog Dimming!**



### Electrical Specifications

Specifications typical @ +25°C, nominal input voltage & rated output current, unless otherwise noted. Specifications subject to change without notice.

#### Input

Parameter	Conditions	Min.	Typ.	Max.	Units
Input Voltage Range		7.0	12	16.0	VDC
Maximum Input Voltage	0.5 Sec			20.0	VDC
Input Filter	Internal Capacitor				

#### Output

Parameter	Conditions	Min.	Typ.	Max.	Units
Output Voltage Range	V <sub>IN</sub> = 16V	2		14	VDC
Output Current	See Model Selection Guide				
Output Current Accuracy	See Model Selection Guide				
Output Power	See Model Selection Guide				
Efficiency	See Model Selection Guide				
Capacitive Load				47	μF
Operating Frequency		60		400	kHz
Ripple & Noise (20 MHz)	See Model Selection Guide				
Temperature Coefficient				±0.03	%/°C
Thermal Impedance	Natural Convection		+35		°C/W
Output Short Circuit	Regulated At Rated Output Current				

#### Environmental

Parameter	Conditions	Min.	Typ.	Max.	Units
Operating Temperature Range	Ambient	-40	+25	+85	°C
	Case			+105	
Storage Temperature Range		-40		+125	°C
Cooling	Free Air Convection				
Humidity	RH, Non-condensing			95	%
Lead Temperature (Solder)	1.5 mm From Case For 10 Sec			260	°C

#### Physical

Case Size	0.50 x 0.40 x 0.27 Inches (12.70 x 10.16 x 6.85 mm)				
Case Material	Non-Conductive Black Plastic (UL94-V0)				
Weight	0.064 Oz (1.8g)				

#### Remote On/Off Control

Parameter	Conditions	Min.	Typ.	Max.	Units
DC/DC On		Open or 0.3V < V <sub>ADJ</sub> < 1.25V			
DC/DC Off		V <sub>ADJ</sub> < 0.15V			
Remote Pin Drive Current	V <sub>ADJ</sub> = 1.25V			1	mA
Quiescent Input Current (Shutdown Mode)	V <sub>IN</sub> = 16V			25	μA

#### PWM Dimming

Parameter	Conditions	Min.	Typ.	Max.	Units
Operation Frequency	Recommended Maximum			1.0	kHz
Switch On Time		200			nS
Switch Off Time		200			nS

#### Analog Dimming

Parameter	Conditions	Min.	Typ.	Max.	Units
Input Voltage Range	At V <sub>ADJ</sub> Input (Pin 7)	0.0		1.25	VDC
Output Current Adjustment		25		100	%
Control Voltage Range Limits	On	0.30		1.25	VDC
	Off	0.0		0.15	
Drive Current	V <sub>ADJ</sub> = 1.25V			1.0	mA

#### EMC Compliance

EMI/RFI	Radiated/Conducted	EN 55015 (CISPR22)		
Electrostatic Discharge (ESD)	Class A	IEC/EN 61000-4-2, -6, -8		
RF Field Susceptibility	Class A	IEC/EN 61000-4-3		
Electrical Fast Transients/Bursts On Mains	Class A	IEC/EN 61000-4-4		
EMS Immunity		EN61547		

#### Reliability Specifications

Parameter	Conditions	Min.	Typ.	Max.	Units
MTBF	MIL HDBK 217F, 25°C, Gnd Benign	3.3			MHours

### MicroPower Direct

292 Page Street  
Suite D  
Stoughton, MA 02072  
USA

T: (781) 344-8226

F: (781) 344-8481

E: sales@micropowerdirect.com

W: www.micropowerdirect.com



[www.micropowerdirect.com](http://www.micropowerdirect.com)

Model Number	Input		Output		Maximum Power (W)	Ripple & Noise (mV P-P, Max)	Efficiency (% Typ)	Package
	Voltage (VDC)	Voltage (VDC)	Current					
	Range	Range	Max (mA)	Accuracy (%)				
LDM12-04-300	7.0 - 16.0	2.0 - 14.0	300	±5	4.2	120	93	8 -Pin MiniDIP
LDM12-05-350	7.0 - 16.0	2.0 - 14.0	350	±6	4.9	150	93	8 -Pin MiniDIP
LDM12-07-500	7.0 - 16.0	2.0 - 14.0	500	±7	7.0	200	93	8 -Pin MiniDIP
LDM12-08-600	7.0 - 16.0	2.0 - 14.0	600	±7	8.4	200	93	8 -Pin MiniDIP
LDM12-10-700	7.0 - 16.0	2.0 - 14.0	700	±7	9.8	250	93	8 -Pin MiniDIP
LDM12-14-1000	7.0 - 16.0	2.0 - 14.0	1,000	±8	14.0	250	93	8 -Pin MiniDIP

**Notes:**

1. A reversed power source could damage the unit.
2. No connection should be made between input ground and the output.
3. These are step-down devices, the maximum output open voltage is equal to the input voltage.
4. The V<sub>ADJ</sub> input should be left open if not used. Grounding V<sub>ADJ</sub> will shut the unit down. Connecting V<sub>ADJ</sub> to V<sub>IN</sub> may damage the unit.
5. Exceeding the specified maximum output power could cause damage to the unit.

**Typical Connection: DC/DC Input**

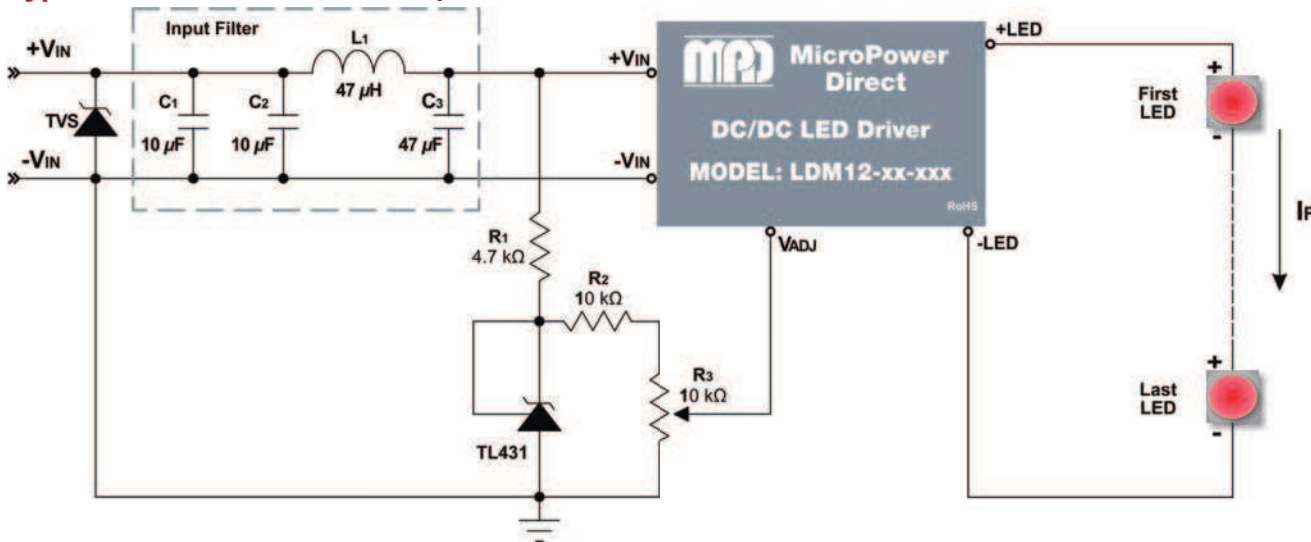

**Connection Notes:**

To comply with EN61000-4-5, a TVS should be installed before the input filter components. A 3.0SMCJ15A or SMCJ16A is recommended. The TVS max clamping voltage (@max peak pulse current I<sub>c</sub>) must be ≤20V. This will prevent any surge from exceeding the maximum input of the driver (20 VDC). Exceeding the maximum input rating could damage the driver.

The filter shown (C1, C2, C3 and L1) will help to meet conducted emission requirements. With the addition of the filter, the unit should meet the levels of EN 55015.

**Typical Connection: AC/DC Input**

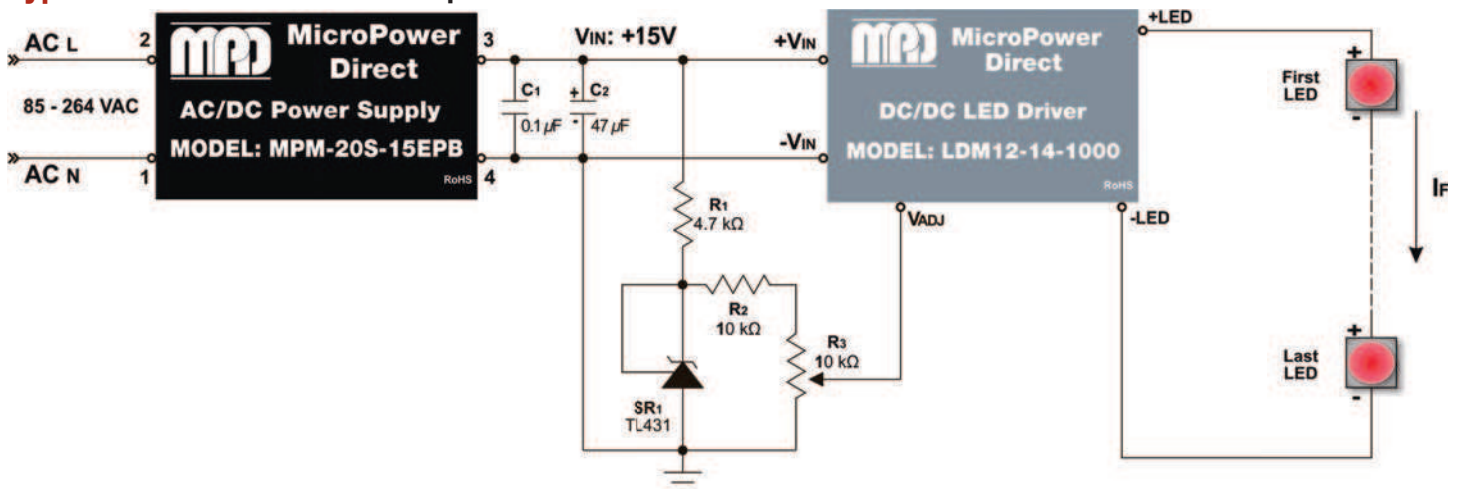

**Connection Notes:**

This is a distributed (or two-stage) AC connection. In this configuration, the AC line in (85 to 264 VAC) is connected to the **MPM-20S-15EPB**, a compact 20W AC/DC power supply. The **MPM-20S-15EPB** provides a tightly regulated 15 VDC output at 1,330 mA. The 15 VDC output powers the LED driver.

The two stage approach can simplify the safety approval process (most AC/DC power supplies on the market are approved to EN 60950) and may increase design flexibility. Besides the output voltage/current ratings, other specifications to consider when selecting the input AC/DC supply might include input range, case size, efficiency, EMI ratings and operating temperature range.

**Note: The output current adjustment circuit shown in both connection diagrams is discussed on page 4.**



## PWM Output Current Control

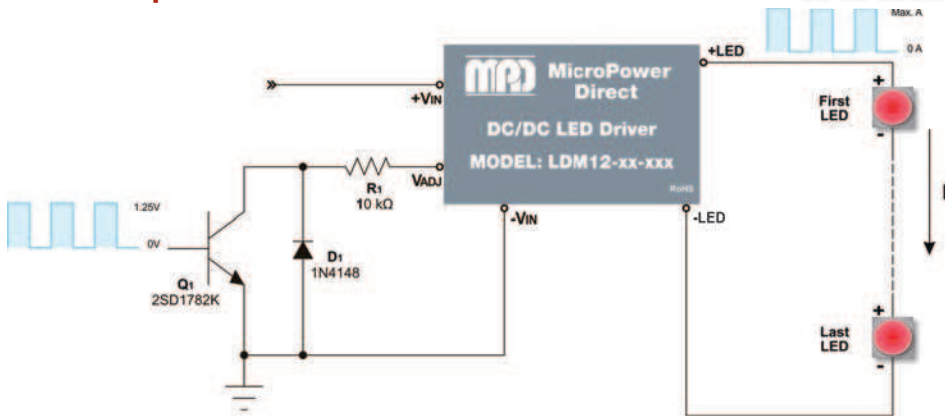

An LED operates at its maximum efficiency when operated at the rated drive current specified by the manufacturer. Operating an LED at lower than its rated forward current not only decreases the system efficiency; but may cause color (or wavelength) shifting. In illumination applications, this could cause visible changes to lighting.

A preferred method is using pulse width modulation (PWM). As shown at left, the output current is adjusted by applying a PWM signal to the VADJ input. By varying the signal duty cycle the average output current is adjusted up or down. To avoid visible flicker, the PWM signal should be greater than 200 Hz.

For duty cycles (DPWM) between 0.1 and 1, the output current is derived by the formula:

$$I_{NOM} = I_{MAX} \times D_{PWM}$$

The VADJ input may be driven via an open collector transistor (as shown). The diode and resistor suppress high amplitude negative spikes that may be caused by the drain-source capacitance of the transistor. Negative spikes on the control input of the unit could cause errors in output current or erratic operation.

The VADJ input can also be driven by the open drain output of a microcontroller. Again, any high amplitude negative spikes that may be caused by the drain-source capacitance of the FET must be suppressed.

## PWM Control Signals

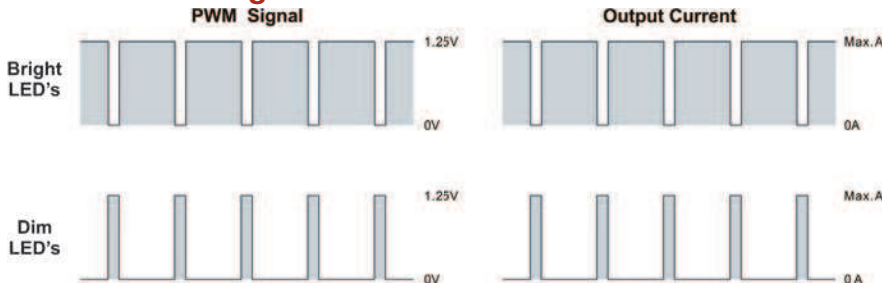

## PWM Dimming Application

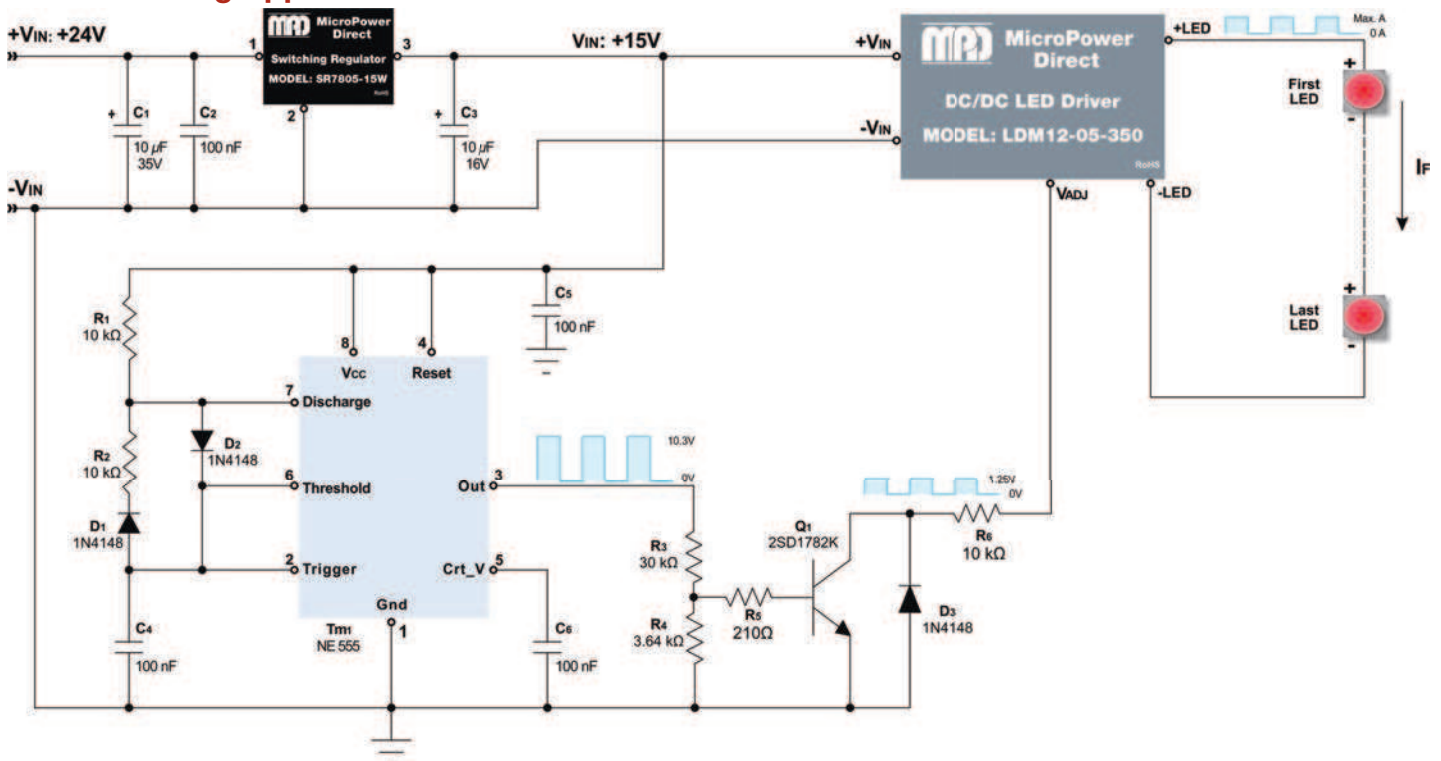

A simple method of achieving digital (or PWM) dimming is by using a 555 timer to apply a series of pulses to the VADJ input, as illustrated above. The 555 operates over a supply voltage range of 4.5 VDC to 18VDC. Here it is connected to the 15 VDC output of the SR7805 switching regulator (this is also the VIN of the LED driver). Care should be taken to minimize ripple at the Vcc input. Excess ripple could cause timing errors.

The timer is connected for astable (free run) operation. The frequency is set by R1, R2 and C4. The timing capacitor (C4) charges through R1 and D2. When it reaches the level of  $\frac{2}{3} V_{cc}$ , the discharge pin (pin 7) goes low and C4 will discharge through D1 and R2 to the internal discharge transistor. When the C4 voltage drops to  $\frac{1}{3} V_{cc}$ , the discharge pin goes high and C4 begins to charge

again. The formulas for calculating the frequency and duty cycle are included in the MPD application note "Driving LEDs".

The diodes (D1 and D2) allow duty cycles below 50% to be set. Diode D1 bypasses R2 while C4 is charging. Diode D2 is optional (but recommended), essentially blocking R2 during the charge period. Theoretically, this circuit will allow for duty cycles over a range of approximately 5% to 95%. If manual adjustment is desired, a potentiometer may be substituted for R2 (with some adjustment of the circuit).

The size of C4 is generally not critical, but it should be as low leakage as possible. In order to avoid excessive current flow through the internal discharge transistor, it is recommended that R1 be at least 5 kΩ.

## Analog Output Current Control (V<sub>CTRL</sub> = 5V)

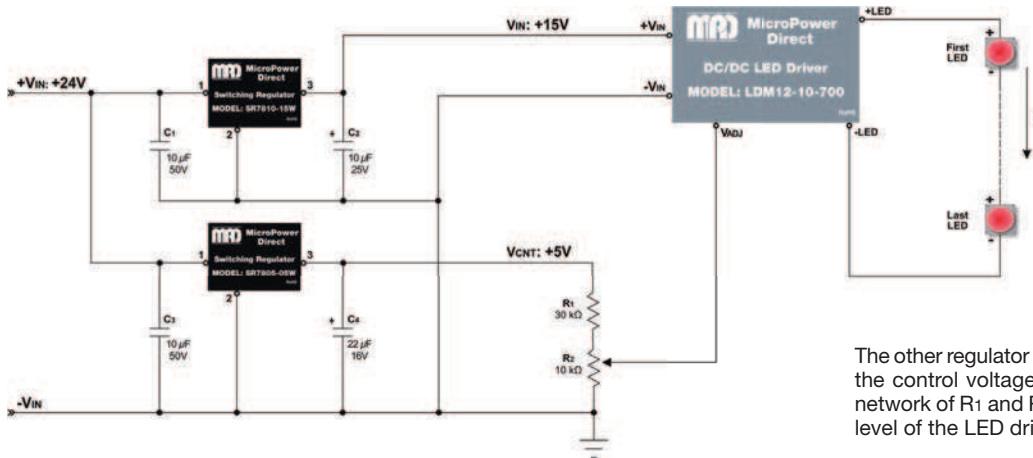

The output current of the unit can also be set by adjusting the voltage level on the V<sub>ADJ</sub> input to a value between 0.3V to 1.25V (I<sub>OUT</sub> will vary from 25% to 100% of rated output current). Care must be taken not to exceed 1.25V on this input, or the driver may be damaged.

A simple analog circuit using two low cost, switching regulators is shown at left. Working from inputs that can range from 20 to 32 VDC, the top regulator (SR1) keeps the input to the LED driver at 15 VDC.

The other regulator (SR2), driven off the same input line maintains the control voltage (for the V<sub>ADJ</sub> input) at 5 VDC. The resistor network of R1 and R2 can now be used to set the output current level of the LED driver. This level is equal to:

$$V_{ADJ} = \frac{R_2}{R_1 + R_2} \times V_{CTRL}$$

In the second circuit, the 5 VDC regulator (SR2) is replaced by the shunt regulator (D1) circuit connected in parallel with the resistor network. The regulator will maintain the voltage across R2 and R3 at 2.5 VDC, insuring that the 1.25 VDC limit on the V<sub>ADJ</sub> pin will not be exceeded.

When using the analog control input, the nominal output current is equal to:

$$I_{NOM} = I_{MAX} \times \frac{V_{ADJ}}{1.25}$$

The V<sub>ADJ</sub> input should be left open if not used. Grounding V<sub>ADJ</sub> will shut the unit down. Connecting V<sub>ADJ</sub> to directly to +V<sub>IN</sub> may damage the unit.

## Analog Output Current Control (5 - 16 VDC IN)

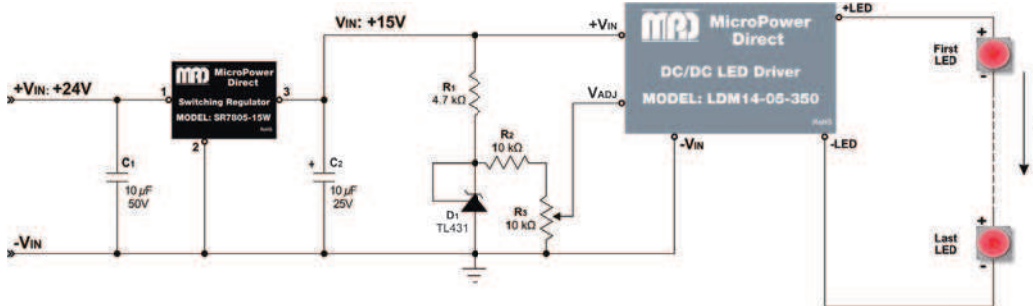

## Mechanical Dimensions

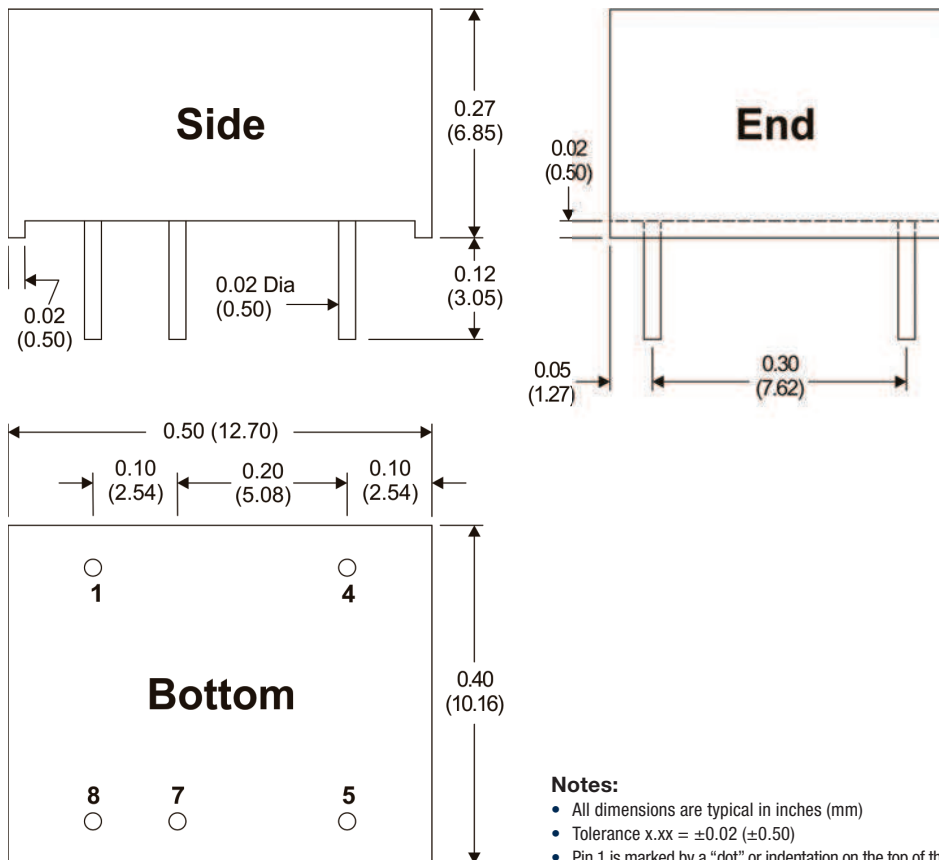

## Pin Connections

Pin	Function
1	+V <sub>IN</sub> +DC Supply
4	+LED LED Anode Conn.
5	-LED LED Cathode Conn.
7	V <sub>ADJ</sub> PWM, On/Off
8	-V <sub>IN</sub> -DC Supply



Get a full explanation of the circuits in this datasheet and more in "Driving LEDs". Available free at the MPD website

### Notes:

- All dimensions are typical in inches (mm)
- Tolerance x.xx = ±0.02 (±0.50)
- Pin 1 is marked by a "dot" or indentation on the top of the unit



**MicroPower Direct**  
We Power Your Success - For Less!