

C4000RU Series

Isolated, 40W Ultra-Wide 4:1 Input DC/DC Converters



Key Features:

- 40W Output Power
- 4:1 Input Voltage Range
- 1,500 VDC Isolation
- -40°C to +85°C Operation
- Single & Dual Outputs
- Remote ON/OFF
- >900 kHour MTBF
- Industry Standard Pin-Out

Electrical Specifications

Specifications typical @ +25°C, nominal input voltage & rated output current, unless otherwise noted. Specifications subject to change without notice.

Input

Parameter	Conditions	Min.	Typ.	Max.	Units
Input Voltage Range	24 VDC Input	9.0	24.0	36.0	VDC
	48 VDC Input	18.0	48.0	75.0	
Input Filter	π (Pi) Filter				
Start Up Time			68		mSec

Output

Parameter	Conditions	Min.	Typ.	Max.	Units
Output Voltage Accuracy			±1.0		%
Line Regulation	For Vin Min to Max			±0.5	%
Load Regulation, See Note 1	I _{out} = 25% to 100%			±0.5	%
Ripple & Noise, See Note 2				85	mV P-P
Transient Recovery Time, See Note 3	50% Load Step Change		250		μSec
Transient Response Deviation			±5.0		%
Output Over Voltage Protection	See Model Selection Guide				
Temperature Coefficient				±0.02	%/°C
Output Short Circuit	Continuous (Autorecovery)				

General

Parameter	Conditions	Min.	Typ.	Max.	Units
Isolation Voltage	60 Seconds	1,500			VDC
Isolation Resistance	500 VDC	1,000			MΩ
Isolation Capacitance	100 kHz, 1V		1,200		pF
Switching Frequency			300		kHz

Remote On/Off, See Note 4

Parameter	Conditions	Min.	Typ.	Max.	Units
Supply On			Open or 3.5 to 12 VDC		
Supply Off			Short or 0.0 to 0.7 VDC		
Standby Input Current				20	mA
Control Common		Referenced to Negative Input (pin 2)			

Environmental

Parameter	Conditions	Min.	Typ.	Max.	Units
Operating Temperature Range	Ambient	-40		+85	°C
Operating Temperature Range	Case			+105	°C
Storage Temperature Range		-55		+125	°C
Cooling	See Derating Curve				
Humidity	RH, Non-condensing			95	%

Physical

Case Size	2.0 x 2.0 x 0.45 Inches (50.8 x 50.8 x 11.4 mm)				
Case Material	Nickel Coated Copper with Non-Conductive Base				
Weight	2.78 Oz (79g)				

Reliability Specifications

Parameter	Conditions	Min.	Typ.	Max.	Units
MTBF	MIL HDBK 217F, 25°C, Gnd Benign	900			kHours

Absolute Maximum Ratings

Parameter	Conditions	Min.	Typ.	Max.	Units
Input Voltage Surge (0.1 Sec)	24 VDC Input	-0.7		50.0	VDC
	48 VDC Input	-0.7		100.0	
Lead Temperature	1.5 mm From Case For 10 Sec			260	°C

Caution: Exceeding Absolute Maximum Ratings may damage the module. These are not continuous operating ratings.



MicroPower Direct

292 Page Street
Suite D
Stoughton, MA 02072
USA

T: (781) 344-8226
F: (781) 344-8481
E: sales@micropowerelect.com
W: www.micropowerelect.com



www.micropowerelect.com

Model Number	Input				Output			Efficiency (Typ %)	Over Voltage Protection (VDC)	Capacitive Load (µF Max)	Fuse Rating Slow-Blow (mA)
	Voltage (VDC)		Current (mA)		Voltage (VDC)	Current (A, Max)	Current (A, Min)				
	Nom.	Range	Full-Load	No-Load							
C4001RU	24	9 - 36	1,677	88	3.3	10.00	0.00	86	3.9	28,000	5,000
C4002RU	24	9 - 36	2,008	119	5.0	8.00	0.00	87	6.2	18,000	5,000
C4003RU	24	9 - 36	2,018	137	12.0	3.35	0.00	87	15	3,800	5,000
C4004RU	24	9 - 36	1,972	112	15.0	2.65	0.00	88	18	3,000	5,000
C4005RU	24	9 - 36	2,012	58	±12.0	±1.65	0.00	86	±15	±2,200	5,000
C4006RU	24	9 - 36	2,058	77	±15.0	±1.35	0.00	86	±18	±1,200	5,000
C4011RU	48	18 - 75	838	49	3.3	10.00	0.00	86	3.9	28,000	2,500
C4012RU	48	18 - 75	992	57	5.0	8.00	0.00	88	6.2	18,000	2,500
C4013RU	48	18 - 75	997	60	12.0	3.35	0.00	88	15	3,800	2,500
C4014RU	48	18 - 75	974	57	15.0	2.65	0.00	89	18	3,000	2,500
C4015RU	48	18 - 75	994	53	±12.0	±1.65	0.00	87	±15	±2,200	2,500
C4016RU	48	18 - 75	1,017	60	±15.0	±1.35	0.00	87	±18	±1,200	2,500

For heatsink option, add suffix "H" to model number (i.e. C4015RU-H)

Notes:

- For dual output models used with unbalanced loads, the load regulation is ±3%.
- When measuring output ripple, it is recommended that external 1.0 µF & 10 µF capacitors be placed in parallel from the +Vout pin to the -Vout pin for single output units and from each output to common for dual output units.
- Transient recovery is measured to within a 1% error band for a load step change of 50% to 100%.
- If the on/off pin is left open, the unit operates. If grounded, the unit will shut off.
- Sense pins should be connected to the output load or to the corresponding output pin.
- No load operation will not damage these units, but they may not meet all spec's.
- It is recommended that a fuse be used on the input of a power supply for protection. See the table above for the correct rating.

Derating Curve

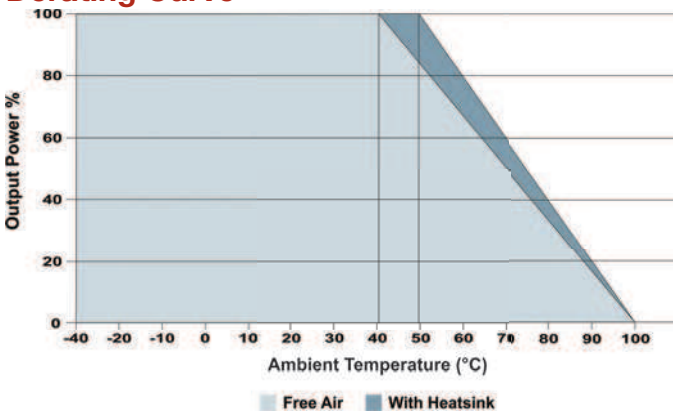

Pin Connections

Pin	Single	Dual
1	+VIN	+VIN
2	-VIN	-VIN
3	On/Off	On/Off
4	-Sense	+VOUT
5	+Sense	Common
6	+VOUT	Common
7	-VOUT	-VOUT
8	Trim	Trim

External Trim

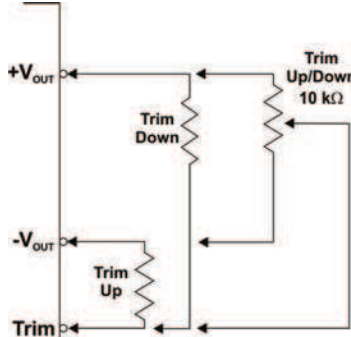

A simple external circuit may be used to adjust the converter output. To adjust the output DOWN, connect a 5%, 3W resistor between the plus output pin and the Vout trim pin. To adjust the output UP, connect a 5%, 3W resistor between the minus output pin and the Vout trim pin.

For UP/Down trimming capability, connect a 10 kW potentiometer between the plus and minus outputs with the wiper arm connected to the Vout trim pin.

The range for the external trim is about ±10%.

Mechanical Dimensions

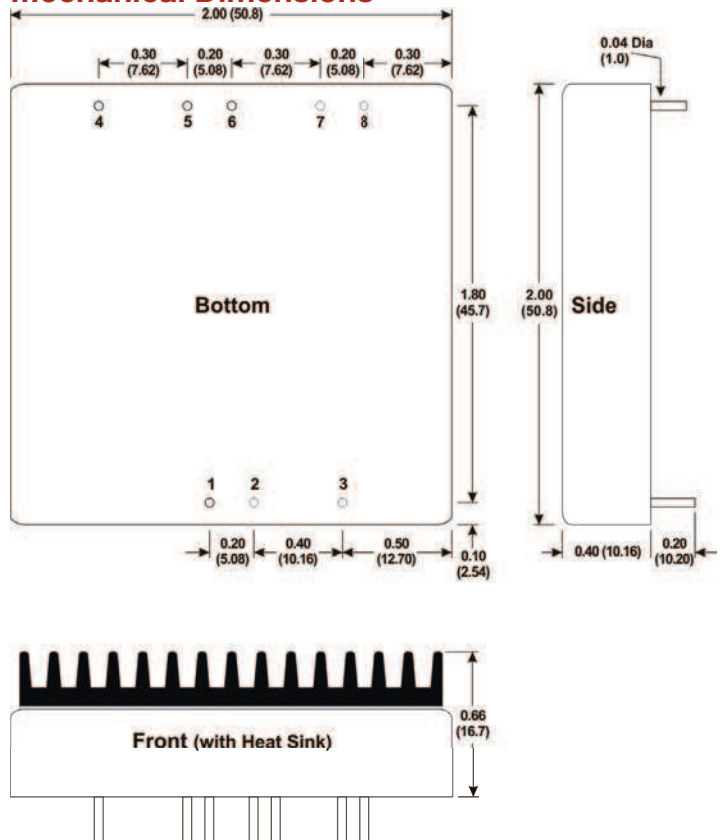

Mechanical Notes:

- All dimensions are typical in inches (mm)
- Tolerance x.xx = ±0.01 (±0.25)



MicroPower Direct
We Power Your Success - For Less!