

# F3000TERU Series

## Compact, 4:1 Input 30W, Triple Output DC/DC Converters



### Key Features:

- 30W Output Power
- 4:1 Input Voltage Range
- 1,500 VDC Isolation
- Triple Outputs
- Compact 1.6 x 2 In. Case
- -40°C to +85°C Operation
- >1.0 MHour MTBF
- Remote ON/OFF
- Industry Standard Pin-Out

Single & Dual  
Output Models  
Available  
F3000TERU Series



RoHS



### MicroPower Direct

292 Page Street  
Suite D  
Stoughton, MA 02072  
USA

T: (781) 344-8226

F: (781) 344-8481

E: sales@micropowerdirect.com

W: www.micropowerdirect.com



### Electrical Specifications

Specifications typical @ +25°C, nominal input voltage & rated output current, unless otherwise noted. Specifications subject to change without notice.

#### Input

Parameter	Conditions	Min.	Typ.	Max.	Units
Input Voltage Range	24 VDC Input	9.0	24.0	36.0	VDC
	48 VDC Input	18.0	48.0	75.0	
Under Voltage Shutdown	24 VDC Input	8.0		9.0	VDC
	48 VDC Input	16.0		17.8	
Input Filter, See Note 1	$\pi$ (Pi) Filter		30		mA
Start Up Time			10		mS

#### Output

Parameter	Conditions	Min.	Typ.	Max.	Units
Output Voltage Accuracy	Main Output		±1.0	±3.0	%
	Auxiliary Outputs		±3.0	±5.0	
Line Regulation, For VIN Min to Max	Main Output			±1.0	%
	Auxiliary Outputs			±5.0	
Load Regulation, IOUT = 10% to 100%	Main Output			±2.0	%
	Auxiliary Outputs			±5.0	
Ripple & Noise, See Note 2			85	120	mV P - P
Output Power Protection		110	130		%
Transient Recovery Time, See Note 3	25% Load Step Change		300	500	$\mu$ Sec
Transient Response Deviation			±3.0	±5.0	%
Temperature Coefficient			±0.03		%/°C
Output Short Circuit	Continuous (Autorecovery)				

#### General

Parameter	Conditions	Min.	Typ.	Max.	Units
Isolation Voltage	60 Seconds	1,500			VDC
Isolation Resistance	500 VDC	1,000			M $\Omega$
Isolation Capacitance	100 kHz, 0.1V		2,000		pF
Switching Frequency			400		kHz

#### Remote On/Off (Note 4)

Parameter	Conditions	Min.	Typ.	Max.	Units
Supply On		3.5		12.0	VDC
Supply Off		-0.0		1.2	VDC
Standby Input Current				1	mA
Control Common	Referenced to Negative Input (pin 2)				

#### Environmental

Parameter	Conditions	Min.	Typ.	Max.	Units
Operating Temperature Range	Ambient	-40		+85	°C
	Case			+105	°C
Storage Temperature Range		-55		+125	°C
Cooling	Free Air Convection				
Humidity	RH, Non-condensing			95	%

#### Physical

Case Size	2.0 x 1.6 x 0.42 Inches (50.8 x 40.6 x 11.8 mm)				
Case Material	Metal with Non-Conductive Base				
Weight	1.76 Oz (50g)				

#### Reliability Specifications

Parameter	Conditions	Min.	Typ.	Max.	Units
MTBF	MIL HDBK 217F, 25°C, Gnd Benign	1,000			kHours

#### Absolute Maximum Ratings

Parameter	Conditions	Min.	Typ.	Max.	Units
Input Voltage Surge (1 Sec)	24 VDC Input	-0.7		40.0	VDC
	48 VDC Input	-0.7		80.0	
Lead Temperature	1.5 mm From Case For 10 Sec			300	°C

**Caution:** Exceeding Absolute Maximum Ratings may damage the module. These are not continuous operating ratings.

[www.micropowerdirect.com](http://www.micropowerdirect.com)

Model Number	Input				Output 1				Outputs 2/3				Efficiency (Typ %)	Fuse Rating Slow-Blow (mA)
	Voltage (VDC)		Current (mA)		Voltage (VDC)	Current (A, Max)	Current (A, Min)	OVP (VDC)	Voltage (VDC)	Current (A, Max)	Current (A, Min)	OVP (VDC)		
Nom.	Range	Full-Load	No-Load											
F3001TERU	24	9 - 36	1,450	30	3.3	3.500	0.175	3.90	±12.0	±0.625	±0.031	± 15.0	85	2,500
F3002TERU	24	9 - 36	1,450	30	3.3	3.500	0.175	3.90	±15.0	±0.500	±0.025	± 18.0	86	2,500
F3003TERU	24	9 - 36	1,420	30	5.0	3.000	0.150	6.20	±12.0	±0.625	±0.031	± 15.0	88	2,500
F3004TERU	24	9 - 36	1,420	30	5.0	3.000	0.150	6.20	±15.0	±0.500	±0.025	± 18.0	88	2,500
F3011TERU	48	18 - 75	720	30	3.3	3.500	0.175	3.90	±12.0	±0.625	±0.031	± 15.0	85	2,000
F3012TERU	48	18 - 75	720	30	3.3	3.500	0.175	3.90	±15.0	±0.500	±0.025	± 18.0	85	2,000
F3013TERU	48	18 - 75	712	30	5.0	3.000	0.150	6.20	±12.0	±0.625	±0.031	± 15.0	88	2,000
F3014TERU	48	18 - 75	712	30	5.0	3.000	0.150	6.20	±15.0	±0.500	±0.025	± 18.0	87	2,000

For Heatsink Option, add suffix "H" to model number (i.e. F3003ERU-H)

**Notes:**

- With the addition of a simple external circuit, the units will pass EN 55022 and EN 61000 EMI specifications. Contact the factory for recommendations.
- When measuring output ripple, it is recommended that an external ceramic capacitor (see table at right) be placed from the +Vout pin to the -Vout pin for single output units and from each output to common for dual output units.
- Transient recovery is measured to within a 1% error band for a load step change of 75% to 100%.
- The Remote On/Off Control input (Pin 4) is referenced to -Vin (Pin 2). This input may be tied directly to ground, but it is recommended that connection to the pin should be made through a 1kΩ resistor and diode (1N4148). If it is not used, the control pin should be left open.
- Operation at no-load will not damage these units. However, they may not meet all specifications.
- It is recommended that a fuse be used on the input of a power supply for protection. See the table above for the correct rating.

Vout	Output Cap.
3.3 VDC	10 μF
5 VDC	10 μF
±12 VDC	±4.7 μF
±15 VDC	±4.7 μF

**Derating Curves**

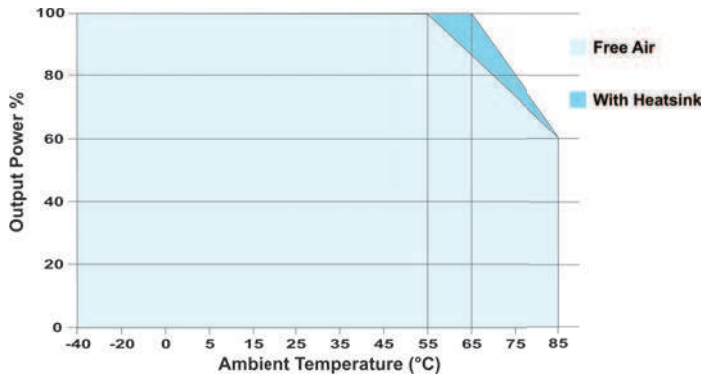

**Mechanical Dimensions**

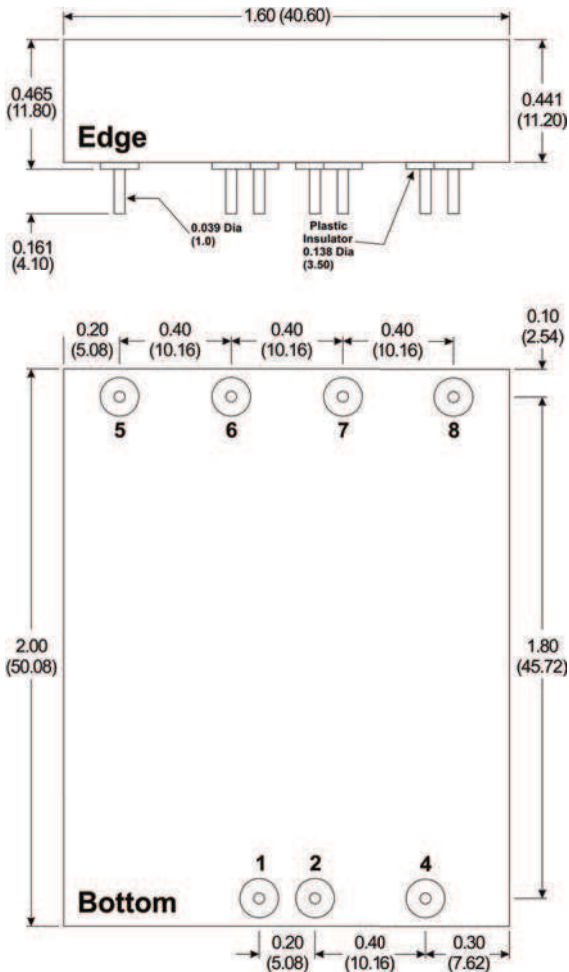

**Heatsink Dimensions (Optional)**

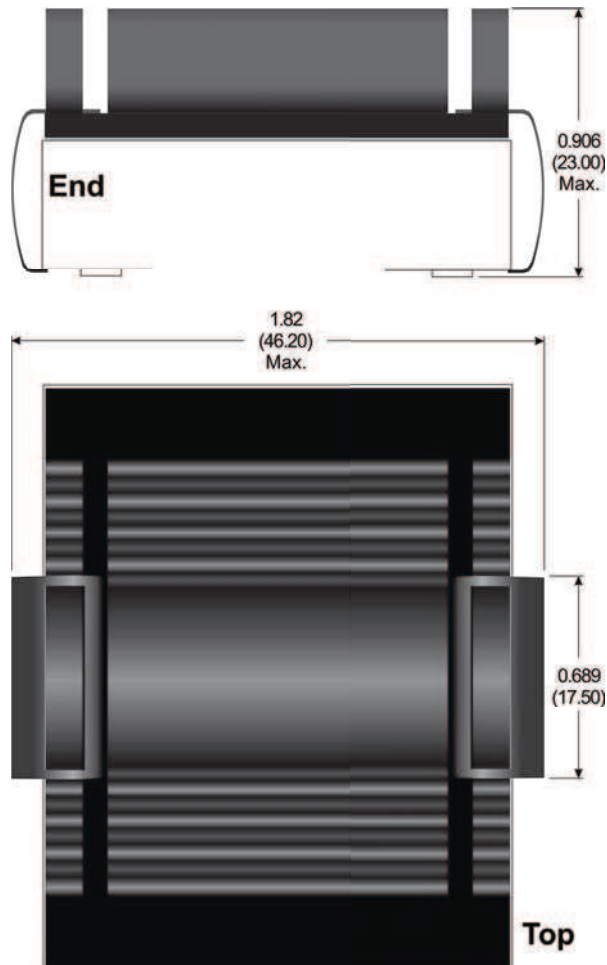

**Pin Connections**

Pin	Function
1	+VIN
2	-VIN
4	ON/OFF
5	+VOUT2
6	+VOUT1
7	-VOUT1
8	-VOUT2



**MicroPower Direct**  
We Power Your Success - For Less!

**Mechanical Notes:**

- All dimensions are typical in inches (mm)
- Tolerance x.xx = ±0.01 (±0.25)