

F2500RW Series



2:1 Input 25W - 30W Single & Dual Output DC/DC Converters

Key Features:

- 25W-30W Output Power
- 2:1 Input Voltage Range
- 1,500 VDC Isolation
- Meets EN55022 Class A
- Compact 2 x 1.6 In. Case
- Single & Dual Outputs
- Remote ON/OFF
- Industry Standard Pin-Out



Electrical Specifications

Specifications typical @ +25°C, nominal input voltage & rated output current, unless otherwise noted. Specifications subject to change without notice.

Input						
Parameter	Conditions	Min.	Typ.	Max.	Units	
Input Start Voltage	12 VDC Input	8.6	8.8	9.0	VDC	
	24 VDC Input	17.0	17.5	18.0		
	48 VDC Input	34.0	35.0	36.0		
Under Voltage Shutdown	12 VDC Input	8.1	8.3	8.5	VDC	
	24 VDC Input	16.0	16.5	17.0		
	48 VDC Input	32.0	33.0	34.0		
Input Filter	π (Pi) Filter (Meets EN55022 Class "A")					
Reverse Polarity Input Current				2.0	A	
Short Circuit Input Power				4,500	mW	
Output						
Parameter	Conditions	Min.	Typ.	Max.	Units	
Output Voltage Accuracy			±0.5	±1.0	%	
Output Voltage Balance	Dual Output , Balanced Loads		±0.5	±2.0	%	
Line Regulation	For Vin Min to Max		±0.1	±0.3	%	
Load Regulation	I _{out} = 50% to 100%		±0.1	±0.5	%	
Ripple & Noise (20 MHz) (Note 1)			55	80	mV P - P	
Ripple & Noise (20 MHz)	Over Line, Load & Temp.			100	mV P - P	
Output Power Protection		110		160	%	
Transient Recovery Time (Note 2)			150	300	μSec	
Transient Response Deviation	25% Load Step Change		±2.0	±4.0	%	
Temperature Coefficient			±0.01	±0.02	%/°C	
Output Short Circuit	Continuous (Autorecovery)					
General						
Parameter	Conditions	Min.	Typ.	Max.	Units	
Isolation Voltage	60 Seconds	1,500			VDC	
Isolation Resistance	500 VDC	1,000			MΩ	
Isolation Capacitance	100 kHz, 1V		1,200	1,500	pF	
Switching Frequency		290	330	360	kHz	
Over Temperature Protection	Case Temperature	107	112	117	°C	
Remote On/Off (Note 3)						
Parameter	Conditions	Min.	Typ.	Max.	Units	
Supply On		2.5		100.0	VDC	
Supply Off		-1.0		1.0	VDC	
Standby Input Current				5	mA	
Control Common	Referenced to Negative Input (pin 2)					
Environmental						
Parameter	Conditions	Min.	Typ.	Max.	Units	
Operating Temperature Range	Ambient	-40		+50	°C	
Operating Temperature Range	Case	-40		+105	°C	
Storage Temperature Range		-50		+125	°C	
Cooling	Free Air Convection					
Humidity	RH, Non-condensing			95	%	
Physical						
Case Size	2.0 x 1.6 x 0.37 Inches (50.8 x 40.6 x 9.3 mm)					
Case Material	Metal with Non-Conductive Base					
Weight	1.75 Oz (48g)					
Reliability Specifications						
Parameter	Conditions	Min.	Typ.	Max.	Units	
MTBF	MIL HDBK 217F, 25°C, Gnd Benign	1,000			kHours	
Absolute Maximum Ratings						
Parameter	Conditions	Min.	Typ.	Max.	Units	
Input Voltage Surge (1 Sec)	12 VDC Input	-0.7		25.0	VDC	
	24 VDC Input	-0.7		50.0		
	48 VDC Input	-0.7		100.0		
Lead Temperature	1.5 mm From Case For 10 Sec			260	°C	
Internal Power Dissipation	All Models			5,500	mW	

Caution: Exceeding Absolute Maximum Ratings may damage the module. These are not continuous operating ratings.

MicroPower Direct

292 Page Street
Suite D
Stoughton, MA 02072
USA

T: (781) 344-8226

F: (781) 344-8481

E: sales@micropowerdirect.com

W: www.micropowerdirect.com



www.micropowerdirect.com

Model Number	Input				Output			Over Voltage Protection (VDC)	Efficiency (% Typ)	Capacitive Load (µF Max)	Fuse Rating Slow-Blow (mA)
	Voltage (VDC)		Current (mA)		Voltage (VDC)	Current (mA, Max)	Current (mA, Min)				
	Nominal	Range	Full-Load	No-Load							
F2501RW	12	9.0 - 18.0	1,867	40	3.3	5,500	400.0	3.9	81	470	6,000
F2502RW	12	9.0 - 18.0	2,480	40	5.0	5,000	350.0	6.8	84	470	6,000
F2503RW	12	9.0 - 18.0	2,841	40	12.0	2,500	166.0	15.0	88	470	6,000
F2504RW	12	9.0 - 18.0	2,841	40	15.0	2,000	133.0	18.0	88	470	6,000
F2505RW	12	9.0 - 18.0	2,841	40	±12.0	±1,250	±83.0	±15.0	88	±220	6,000
F2506RW	12	9.0 - 18.0	2,841	40	±15.0	±1,000	±65.0	±18.0	88	±220	6,000
F2511RW	24	18.0 - 36.0	922	20	3.3	5,500	400.0	3.9	82	470	3,000
F2512RW	24	18.0 - 36.0	1,225	20	5.0	5,000	350.0	6.8	85	470	3,000
F2513RW	24	18.0 - 36.0	1,404	20	12.0	2,500	166.0	15.0	89	470	3,000
F2514RW	24	18.0 - 36.0	1,404	20	15.0	2,000	133.0	18.0	89	470	3,000
F2515RW	24	18.0 - 36.0	1,404	20	±12.0	±1,250	±83.0	±15.0	89	±220	3,000
F2516RW	24	18.0 - 36.0	1,404	20	±15.0	±1,000	±65.0	±18.0	89	±220	3,000
F2521RW	48	36.0 - 75.0	461	10	3.3	5,500	400.0	3.9	82	470	1,500
F2522RW	48	36.0 - 75.0	613	10	5.0	5,000	350.0	6.8	85	470	1,500
F2523RW	48	36.0 - 75.0	702	10	12.0	2,500	166.0	15.0	89	470	1,500
F2524RW	48	36.0 - 75.0	702	10	15.0	2,000	133.0	18.0	89	470	1,500
F2525RW	48	36.0 - 75.0	702	10	±12.0	±1,250	±83.0	±15.0	89	±220	1,500
F2526RW	48	36.0 - 75.0	702	10	±15.0	±1,000	±65.0	±18.0	89	±220	1,500

For Heatsink Option, add suffix "H" to model number (i.e. F2503RW-H)

Notes:

- When measuring output ripple, it is recommended that an external 1.0 µF ceramic capacitor be placed from the +Vout pin to the -Vout pin for single output units and from each output to common for dual output units. For noise sensitive applications, the use of 4.7 µF capacitors will reduce the output ripple. The maximum rms value of the output ripple is 10 mV.
- Transient recovery is measured within a 1% error band for a 75-100% load change.
- The maximum sink current at the on/off pin (pin 4) during a logic low is 100 µA. The maximum allowable leakage current of a switch connected to the on/off pin (Pin 4) at logic high (2.5V to 100V) is 5 µA. If the on/off pin (Pin 4) is left open, the unit operates. If it is grounded, the unit will shut off.
- No load operation will not damage these units, but they may not meet all spec's.
- Dual output units may be connected to provide a 24 VDC or 30 VDC output. To do this, connect the load across the positive (+Vout) and negative (-Vout) outputs and float the output common.
- The converter should be connected to a low ac-impedance source. An input source with a highly inductive impedance may affect the stability of the converter. In applications where the converter output loading is high and input power is supplied over long lines, it may be necessary to use a capacitor on the input to insure start-up. In this case, it is recommended that a low Equivalent Series Resistance (ESR <1.0Ω at 100 kHz) capacitor be mounted close to the converter. A 33 µF is recommended for 24V input models and a 10 µF for 48V units.
- It is recommended that a fuse be used on the input of a power supply for protection. See the table above for the correct rating.

Mechanical Dimensions

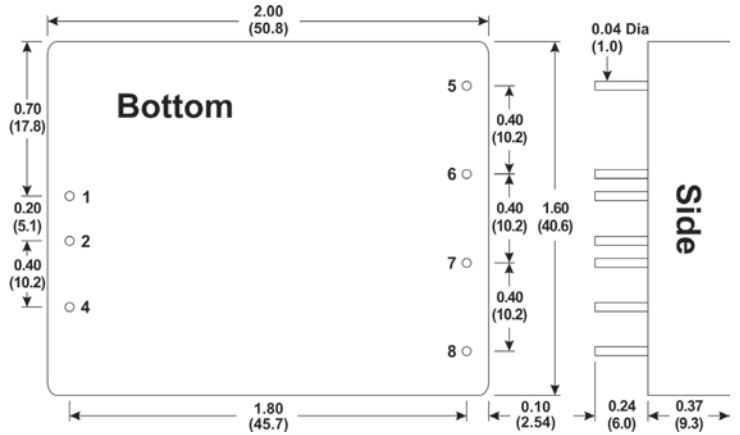

External Trim

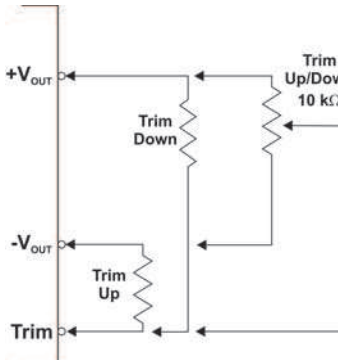

A simple external circuit may be used to adjust the converter output. To adjust the output DOWN, connect a 5%, 3W resistor between the plus output pin and the Vout trim pin. To adjust the output UP, connect a 5%, 3W resistor between the minus output pin and the Vout trim pin. To calculate the correct resistor value use:

$$UP \quad Radj = \frac{(33 \times Vout) - (30 \times Vadj)}{Vadj - Vout}$$

$$Down \quad Radj = \frac{(36.667 \times Vout) - (33 \times Vout)}{Vout - Vadj}$$

For UP/Down trimming capability, connect a 10 kW potentiometer between the plus and minus outputs with the wiper arm connected to the Vout trim pin.

Pin Connections

Pin	Single	Dual	Pin	Single	Dual
1	+Vin	+Vin	6	+Vout	Comm.
2	-Vin	-Vin	7	-Vout	-Vout
4	ON/OFF	ON/OFF	8	Trim	Trim
5	No Pin	+Vout			

Mechanical Notes:

- All dimensions are typical in inches (mm)
- Tolerance x.xx = ±0.01 (±0.25)

Heatsink Dimensions (Optional)

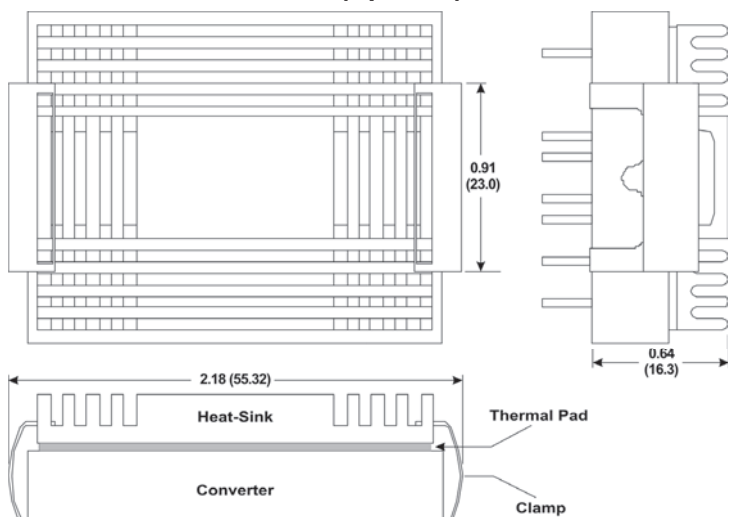

Derating Curves

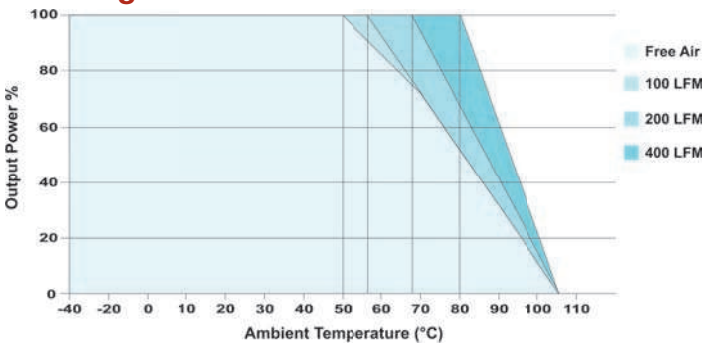

Heatsink Notes:

- Use of the heatsink will extend the units operating temperature range by approximately 10°C.
- The heatsink is black anodized aluminum.



MicroPower Direct
We Power Your Success - For Less!