

MI600ERU Series

4:1 Input, 6W Ultra-Miniature DC/DC Converters



Key Features:

- 6W Output Power
- 4:1 Input Range
- Miniature 1" x 1" Case
- Single & Dual Outputs
- 1,500 VDC Isolation
- >1 MHour MTBF
- 16 Standard Models
- **LOW COST!!**



Electrical Specifications

Specifications typical @ +25°C, nominal input voltage & rated output current, unless otherwise noted. Specifications subject to change without notice.

Input

Parameter	Conditions	Min.	Typ.	Max.	Units
Input Voltage Range	24 VDC Input	9.0	24.0	36.0	VDC
	48 VDC Input	18.0	48.0	75.0	
Input Filter	Pi (π) Filter				

Output

Parameter	Conditions	Min.	Typ.	Max.	Units
Output Voltage Accuracy			±1.0	±2.0	%
Output Voltage Balance	Dual Output, Balanced Loads		±0.5	±1.5	%
Line Regulation	Vin = Min to Max		±0.2	±0.5	%
Load Regulation, See Note 1	Iout = 5% to 100%		±0.5	±1.0	%
Ripple (20 MHz)	See Note 2		15	25	mV P - P
Noise (20 MHz)	See Note 2		50	75	mV P - P
Transient Recovery Time, See Note 3	25% Load Step Change		300	500	μSec
Transient Response Deviation			±3.0	±5.0	%
Temperature Coefficient			±0.03		%/°C
Output Over Voltage Protection		110		140	%VOUT
Output Over Load Protection		120		180	%IOUT
Output Short Circuit	Continuous (Autorecovery)				

General

Parameter	Conditions	Min.	Typ.	Max.	Units
Isolation Voltage	60 Seconds	1,500			VDC
Isolation Resistance	500 VDC	1,000			MΩ
Isolation Capacitance	100 kHz, 1V		1,000		pF
Switching Frequency			300		kHz

EMI Characteristics

Parameter	Standard	Min.	Typ.	Max.	Units
Radiated Emissions	See Note 4 EN 55022			Class A	
Conducted Emissions	See Note 4 EN 55022			Class A	
ESD	EN 61000-4-2			Criteria B; ±4 kV Contact	
RS	EN 61000-4-3			Criteria A; 10V/m	
EFT	See Note 5 EN 61000-4-4			Criteria B; ±2 kV	
Surge	See Note 6 EN 61000-4-5			Criteria B; ±2 kV	
CS	EN 61000-4-6			Criteria A; 3 Vrms	
Voltage Dips	EN 61000-4-29			Criteria B; 0% - 70%	

Environmental

Parameter	Conditions	Min.	Typ.	Max.	Units
Operating Temperature Range	Ambient	-40		+85	°C
Operating Temperature Range	Case			+105	°C
Storage Temperature Range		-55		+125	°C
Cooling	Free Air Convection				
Humidity	RH, Non-condensing			95	%

Physical

Case Size	1.00 x 1.00 x 0.461 Inches (25.4 x 25.4 x 11.7 mm)
Case Material	Aluminum (UL94-V0)
Weight	0.48 Oz (14g)

Reliability Specifications

Parameter	Conditions	Min.	Typ.	Max.	Units
MTBF	MIL HDBK 217F, 25°C, Gnd Benign	1.0			MHours

Absolute Maximum Ratings

Parameter	Conditions	Min.	Typ.	Max.	Units
Input Voltage Surge (1 Sec)	24 VDC Input	-0.7		50.0	VDC
	48 VDC Input	-0.7		100.0	
Lead Temperature	1.5 mm From Case For 10 Sec			300	°C

Caution: Exceeding Absolute Maximum Ratings may damage the module. These are not continuous operating ratings.

MicroPower Direct

292 Page Street
Suite D
Stoughton, MA 02072
USA

T: (781) 344-8226

F: (781) 344-8481

E: sales@micropowerdirect.com

W: www.micropowerdirect.com



www.micropowerdirect.com

Model Number	Input				Output			Capacitive Load (μ F Max)	Efficiency (% Typ)	Fuse Rating Slow-Blow (mA)
	Voltage (VDC)		Current (mA)		Voltage (VDC)	Current (mA, Max)	Current (mA, Min)			
	Nominal	Range	Full-Load	No-Load						
MI624S-03ERU	24	9.0 - 36.0	261	7	3.3	1,500	75	1,800	79	1500
MI624S-05ERU	24	9.0 - 36.0	301	7	5.0	1,200	60	1,000	83	1500
MI624S-12ERU	24	9.0 - 36.0	287	7	12.0	500	25	100	87	1500
MI624S-15ERU	24	9.0 - 36.0	284	7	15.0	400	20	100	88	1500
MI624S-24ERU	24	9.0 - 36.0	284	7	24.0	250	12	47	88	1500
MI624D-05ERU	24	9.0 - 36.0	301	7	\pm 5.0	\pm 600	\pm 30	470	83	1500
MI624D-12ERU	24	9.0 - 36.0	287	7	\pm 12.0	\pm 250	\pm 12	100	87	1500
MI624D-15ERU	24	9.0 - 36.0	284	7	\pm 15.0	\pm 200	\pm 10	100	88	1500
MI648S-03ERU	48	18.0 - 75.0	130	3	3.3	1,500	75	1,800	79	750
MI648S-05ERU	48	18.0 - 75.0	151	3	5.0	1,200	60	1,000	83	750
MI648S-12ERU	48	18.0 - 75.0	143	3	12.0	500	25	100	87	750
MI648S-15ERU	48	18.0 - 75.0	142	3	15.0	400	20	100	88	750
MI648S-24ERU	48	18.0 - 75.0	142	3	24.0	250	12	47	88	750
MI648D-05ERU	48	18.0 - 75.0	151	3	\pm 5.0	\pm 600	\pm 30	470	83	750
MI648D-12ERU	48	18.0 - 75.0	143	3	\pm 12.0	\pm 250	\pm 12	100	87	750
MI648D-15ERU	48	18.0 - 75.0	142	3	\pm 15.0	\pm 200	\pm 10	100	88	750

Notes:

- The load regulation of dual output units with unbalanced loads is \pm 5%.
- When measuring output ripple, it is recommended that an external ceramic capacitor (approx 1 μ F to 10 μ F) be placed from the +Vout pin to the -Vout pin for single output units and from each output to common for dual output units.
- Operation at no-load will not damage these units. However, they may not meet all specifications. The recommended minimum load is given in the model selection table above.

- All units are rated for EN 55022 (CE/RE) class A without external components. They will meet class B with the addition of the DCFM-01 (or a similar discrete filter circuit). Contact the factory for more information.
- The external EMS components shown in the typical connection diagram are required meet EN 61000-4-4, \pm 2 kV. The addition of the DCFM-01 filter module will bring it to \pm 4 kV. Contact the factory for more information.
- The external EMS components shown in the typical connection diagram are required meet EN 61000-4-5, \pm 2 kV. This level can also be achieved with the DCFM-01 filter module. Contact the factory for more information.
- It is recommended that a fuse be used on the input of a power supply for protection. See the Model Selection table above for the correct rating.

Typical Connection

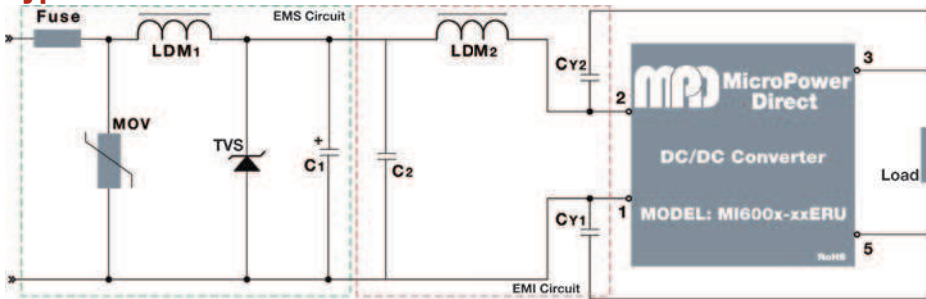

The diagram at left illustrates a typical application connection of the MI600x-ERW series. Shown are components for external EMI and/or EMS circuits. recommended values for the components shown are:

Output	MI624x-ERU	MI648x-ERU
Fuse	See Table Above	
MOV	10D560k	10D101k
LDM1	56 μ H	56 μ H
TVS	SMCJ48A	SMCJ90A
C1	120 μ F/50V	120 μ F/100V
C2	2.2 μ F/50V	2.2 μ F/100V
LDM2	4.7 μ H	4.7 μ H
CY1	1000 pF/2000V	1000 pF/2000V
CY2	1000 pF/2000V	1000 pF/2000V

Typical Board Layout: With DCFM-01 Input Module (See note at right)

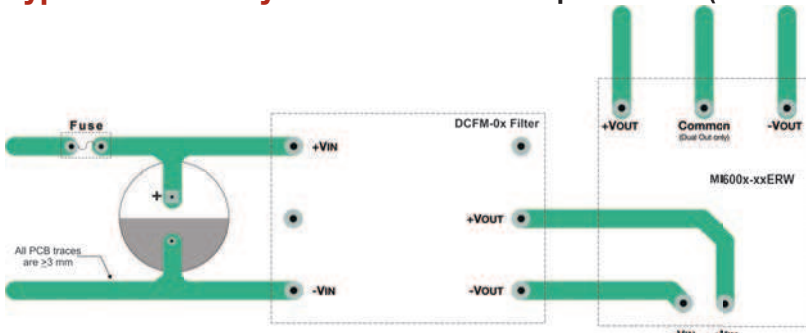

Input noise and surge suppression modules are available for a number of MPD DC/DC converters. An MI600xERU connection with the DCFM-01/02 is illustrated in the diagram at left. For pricing or full technical information on these modules (DCFM-01 and DCFM-02) please contact the factory.

Pin Connections

Pin	Single	Dual	Pin	Single	Dual
1	+VIN	+VIN	3	+VOUT	+VOUT
2	-VIN	-VIN	4	No Pin	Common
			5	-VOUT	-VOUT

Derating Curve

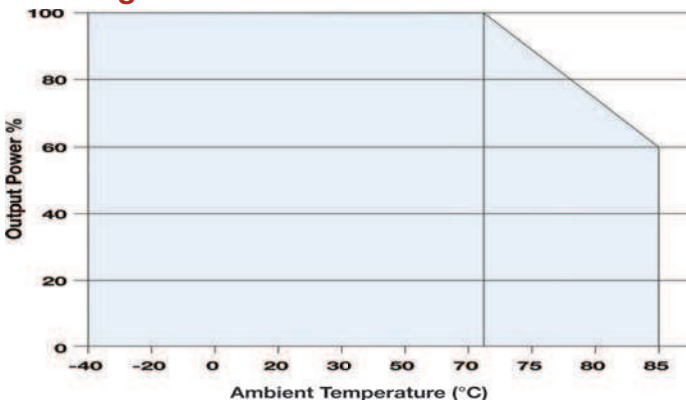

Mechanical Dimensions

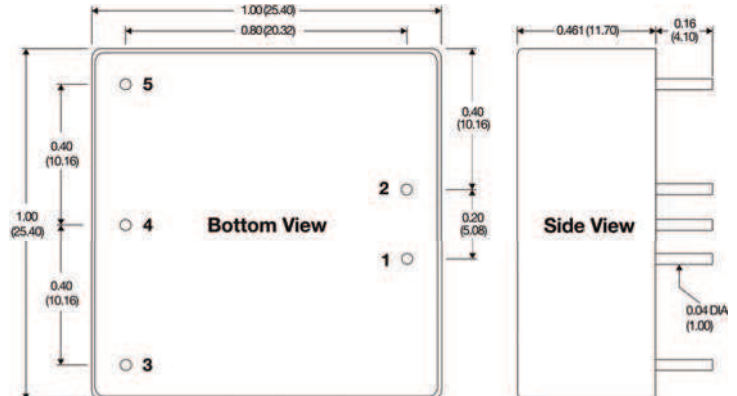

Notes:

- All dimensions are typical in inches (mm)
- Tolerance x.xx = \pm 0.01 (\pm 0.25)
- Pin 1 is marked by a "dot" on the top of the unit



MicroPower Direct
We Power Your Success - For Less!