

D300RW Series

Single & Dual Output 3W SIP, Wide Input DC/DC Converters

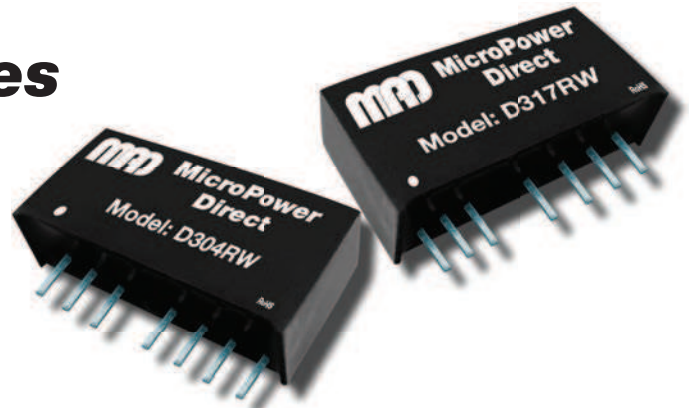

Key Features:

- 3W Output Power
- 2:1 Input Voltage Range
- 1,500 VDC Isolation
- Short Circuit Protected
- Miniature SIP Case
- Single & Dual Outputs
- 1.0 MH MTBF
- Industry Standard Pin-Out



Electrical Specifications

Specifications typical @ +25°C, nominal input voltage & rated output current, unless otherwise noted. Specifications subject to change without notice.

Input

Parameter	Conditions	Min.	Typ.	Max.	Units
Input Voltage Range	12 VDC Input	9.0	12.0	18.0	VDC
	24 VDC Input	18.0	24.0	36.0	
	48 VDC Input	36.0	24.0	72.0	

Output

Parameter	Conditions	Min.	Typ.	Max.	Units
Output Voltage Accuracy			±3.0		%
Line Regulation	Vin = Min to Max		±0.2	±0.5	%
Load Regulation, Single Output	Iout = 10% to 100%		±0.5	±0.75	%
Load Regulation, Dual Output	Iout = 10% to 100%		±0.5	±1.0	%
Ripple & Noise (20 MHz)	See Note 1		50	100	mV P - P
Temperature Coefficient				±0.03	%/°C
Output Short Circuit	Continuous (Autorecovery)				

General

Parameter	Conditions	Min.	Typ.	Max.	Units
Isolation Voltage	60 Seconds	1,500			VDC
Isolation Resistance	500 VDC	1,000			MΩ
Isolation Capacitance	100 kHz, 1V		80		pF
Switching Frequency	Iout = 100%		300		kHz

Environmental

Parameter	Conditions	Min.	Typ.	Max.	Units
Operating Temperature Range	Ambient	-40	+25	+85	°C
Storage Temperature Range		-55		+125	°C
Cooling	Free Air Convection				
Humidity	RH, Non-condensing			95	%

Physical

Case Size	0.87 x 0.47 x 0.37 Inches (22.0 x 12.0 x 9.50 mm)				
Case Material	Non-Conductive Black Plastic (UL94-V0)				
Weight	0.20 Oz (6.0g)				

Reliability Specifications

Parameter	Conditions	Min.	Typ.	Max.	Units
MTBF	MIL HDBK 217F, 25°C, Gnd Benign	1.0			MHours

Absolute Maximum Ratings

Parameter	Conditions	Min.	Typ.	Max.	Units
Input Voltage Surge (1 Sec)	12 VDC Input	-0.7		22.0	VDC
	24 VDC Input	-0.7		40.0	
	48 VDC Input	-0.7		80.0	
Lead Temperature	1.5 mm From Case For 10 Sec			300	°C

Caution: Exceeding Absolute Maximum Ratings may damage the module. These are not continuous operating ratings.

MicroPower Direct

292 Page Street
Suite D
Stoughton, MA 02072
USA

T: (781) 344-8226
F: (781) 344-8481
E: sales@micropowerdirect.com
W: www.micropowerdirect.com



www.micropowerdirect.com

Model Number	Input				Output (See Note 4)			Capacitive Load (μF, Max)	Efficiency (% Typ)	Fuse Rating Slow-Blow (mA)
	Voltage (VDC)		Current (mA)		Voltage (VDC)	Current (mA, Max)	Current (mA, Min)			
	Nominal	Range	Full-Load	No-Load						
D301RW	12	9.0 - 18.0	338	22	5.0	600.0	60.0	1,000	74	700
D302RW	12	9.0 - 18.0	329	22	9.0	333.0	33.0	680	76	700
D303RW	12	9.0 - 18.0	338	22	12.0	250.0	25.0	470	74	700
D304RW	12	9.0 - 18.0	333	22	15.0	200.0	20.0	330	75	700
D305RW	12	9.0 - 18.0	338	22	±5.0	±300.0	±30.0	±680	74	700
D306RW	12	9.0 - 18.0	329	22	±9.0	±167.0	±17.0	±470	76	700
D307RW	12	9.0 - 18.0	320	22	±12.0	±125.0	±13.0	±330	78	700
D308RW	12	9.0 - 18.0	316	22	±15.0	±100.0	±10.0	±220	79	700
D311RW	24	18.0 - 36.0	164	10	5.0	600.0	60.0	1,000	76	350
D312RW	24	18.0 - 36.0	160	10	9.0	333.0	33.0	680	78	350
D313RW	24	18.0 - 36.0	156	10	12.0	250.0	25.0	470	80	350
D314RW	24	18.0 - 36.0	156	10	15.0	200.0	20.0	330	80	350
D315RW	24	18.0 - 36.0	164	10	±5.0	±300.0	±30.0	±680	76	350
D316RW	24	18.0 - 36.0	160	10	±9.0	±167.0	±17.0	±470	78	350
D317RW	24	18.0 - 36.0	158	8	±12.0	±125.0	±13.0	±330	79	350
D318RW	24	18.0 - 36.0	156	8	±15.0	±100.0	±10.0	±220	80	350
D321RW	48	36.0 - 72.0	83	6	5.0	600.0	60.0	1,000	75	700
D323RW	48	36.0 - 72.0	80	6	12.0	250.0	25.0	470	78	700
D324RW	48	36.0 - 72.0	78	6	15.0	200.0	20.0	470	80	700

Notes:

- When measuring output ripple, it is recommended that an external ceramic capacitor (approx. 1 μF to 10 μF) be placed from the +Vout pin to the -Vout pin for single output units and from each output to common for dual output units.
- These units should not be operated with a load under 10% of full load. Operation at no-load may cause damage to the unit.
- Connection to the control (remote on/off) input must be made as shown in the typical connection diagram at right. This input is referenced to the -Vin pin. Input current to the pin (Ic) should be between 5 - 10 mA with a maximum of 20 mA. Exceeding 20 mA could cause damage to the unit. If not used, the pin should be left open. Grounding the pin could damage the unit. The value for R1 can be calculated by the formula at right.
- To insure proper operation over the full load range of 10% to 100%, a 100 μF capacitor should be connected across each output (as shown in the typical connection diagrams at right). In some applications the addition of input components may further enhance stability. Recommended capacitor values are given in the table at right. Recommended inductor values would be 4.7-120 μH for the input and 2.2-10 μH for the output. Output ripple on single output units may be further enhanced by using the CS terminal (single output units operated at 50% load or below should use this function). A low ESR capacitor is connected between the CS pin and the -Vout pin (the anode of the capacitor is connected to the -Vout pin). Recommended capacitor values are 10 - 47 μF. If not used, the CS pin should be left open.
- Dual output units may be connected to provide a 10V, 24V, or 30VDC output. To do this, connect the load across the +Vout and -Vout outputs and float the output common.
- It is recommended that a fuse be used on the input of a power supply for protection. See the Model Selection table above for the correct rating.

	Min	Max
On	<0.6 VDC	to Open Circuit
Off	2.7 VDC	15.0 VDC

$$R_1 = \frac{V_c - V_D - 1}{I_c}$$

Vin	Input Capacitor	Vout	Output Capacitor
12 VDC	100 μF	5 VDC	100 μF
24 VDC	10 - 47 μF	9 VDC	100 μF
48 VDC	10 - 47 μF	12 VDC	100 μF
		15 VDC	100 μF

Pin Connections

Pin	Single	Dual	Pin	Single	Dual
1	-Vin	-Vin	6	+Vout	+Vout
2	+Vin	+Vin	7	-Vout	Common
3	Remote ON/OFF		8	CS	-Vout
5	NC	NC			

NC = No Connection

Derating Curve

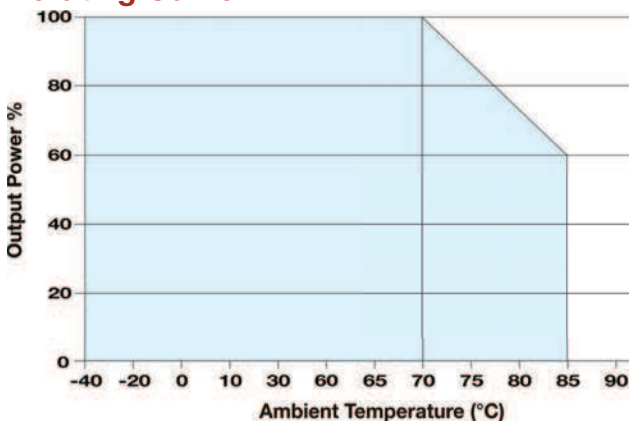

Typical Connection

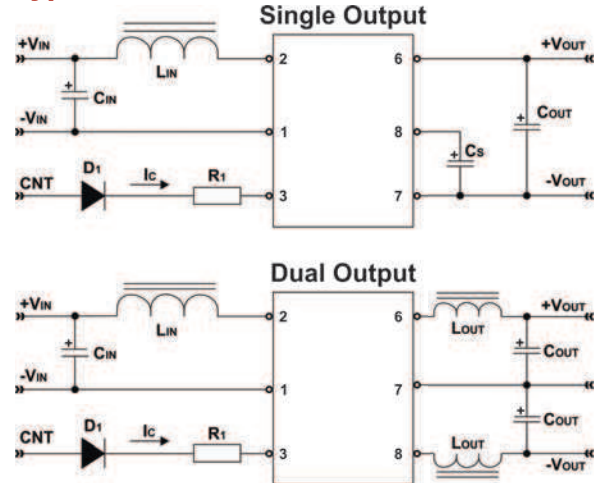

Mechanical Dimensions

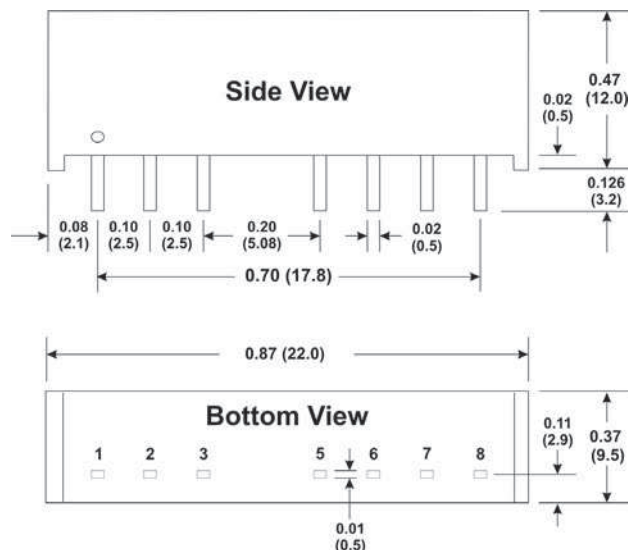

Mechanical Notes:

- All dimensions are typical in inches (mm)
- Tolerance x.xx = ±0.01 (±0.25)



MicroPower Direct
 We Power Your Success - For Less!