

# D200ERW Series

## Low Cost, Miniature 2W SIP, Wide Input DC/DC Converters

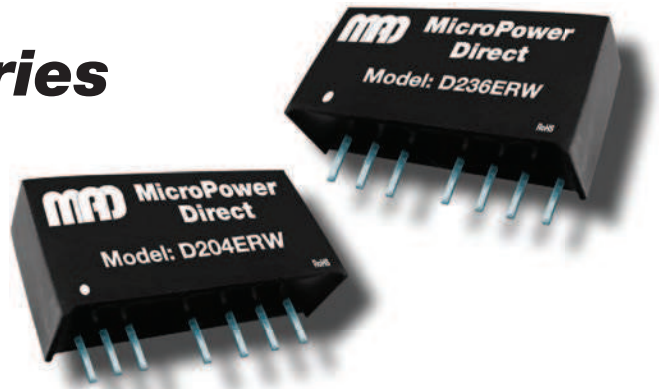

### Key Features:

- 2W Output Power
- 2:1 Input Voltage Range
- 1,500 VDC Isolation
- Short Circuit Protected
- Miniature SIP Case
- Single & Dual Outputs
- 1.0 MH MTBF
- Industry Standard Pin-Out
- **Low Low Cost!!**



### MicroPower Direct

292 Page Street  
Suite D  
Stoughton, MA 02072  
USA

T: (781) 344-8226

F: (781) 344-8481

E: sales@micropowerdirect.com

W: www.micropowerdirect.com



### Electrical Specifications

Specifications typical @ +25°C, nominal input voltage & rated output current, unless otherwise noted. Specifications subject to change without notice.

Parameter	Conditions	Min.	Typ.	Max.	Units
Input Voltage Range	5 VDC Input	4.5	5.0	9.0	VDC
	12 VDC Input	9.0	12.0	18.0	
	24 VDC Input	18.0	24.0	36.0	
	48 VDC Input	36.0	48.0	72.0	

Parameter	Conditions	Min.	Typ.	Max.	Units
Output Voltage Accuracy			±1.0	±3.0	%
Output Voltage Balance			±1.0	±2.0	%
Line Regulation	Vin = Min to Max		±0.2	±0.5	%
Load Regulation, Single Output	Iout = 10% to 100%		±0.5	±0.75	%
Load Regulation, Dual Output	Iout = 10% to 100%		±0.5	±1.0	%
Ripple & Noise (20 MHz)	See Note 1		35	100	mV P - P
Temperature Coefficient				±0.03	%/°C
Output Short Circuit	Continuous (Autorecovery)				

Parameter	Conditions	Min.	Typ.	Max.	Units
Isolation Voltage	60 Seconds	1,500			VDC
Isolation Resistance	500 VDC	1,000			MΩ
Isolation Capacitance	100 kHz, 1V		80		pF
Switching Frequency	Iout = 100%	180		500	kHz

Parameter	Conditions	Min.	Typ.	Max.	Units
Operating Temperature Range	Ambient	-40	+25	+85	°C
Output Derating		3.4%/°C from +71°C to +100°C			
Storage Temperature Range		-50		+125	°C
Cooling	Free Air Convection				
Humidity	RH, Non-condensing			95	%

Parameter	Conditions	Min.	Typ.	Max.	Units
Case Size		0.87 x 0.47 x 0.37 Inches (22.0 x 12.0 x 9.50 mm)			
Case Material		Non-Conductive Black Plastic (UL94-V0)			
Weight		0.19 Oz (5.5g)			

Parameter	Conditions	Min.	Typ.	Max.	Units
Unit On	See Note 3	Open or High Impedance			
Unit Off	See Note 3	2.7 VDC To 15 VDC			
Off Idle Current			5.0		mA

Parameter	Conditions	Min.	Typ.	Max.	Units
MTBF	MIL HDBK 217F, 25°C, Gnd Benign	1.0			MHours

Parameter	Conditions	Min.	Typ.	Max.	Units
Input Voltage Surge (1 Sec)	5 VDC Input	-0.7		11.0	VDC
	12 VDC Input	-0.7		22.0	
	24 VDC Input	-0.7		40.0	
	48 VDC Input	-0.7		80.0	
Lead Temperature	1.5 mm From Case For 10 Sec			300	°C

Caution: Exceeding Absolute Maximum Ratings may damage the module. These are not continuous operating ratings.

[www.micropowerdirect.com](http://www.micropowerdirect.com)

# Model Selection Guide

Model Number	Input				Output			Capacitive Load (μF, Max)	Efficiency (% Typ)	Fuse Rating Slow-Blow (mA)
	Voltage (VDC)		Current (mA)		Voltage (VDC)	Current (mA, Max)	Current (mA, Min)			
	Nominal	Range	Full-Load	No-Load						
D201ERW	5	4.5 - 9.0	508	40	3.3	500.0	50.0	2,200	65	1,500
D202ERW	5	4.5 - 9.0	588	40	5.0	400.0	40.0	1,000	68	1,500
D203ERW	5	4.5 - 9.0	555	40	9.0	222.0	22.0	820	72	1,500
D204ERW	5	4.5 - 9.0	547	40	12.0	166.0	16.0	680	73	1,500
D205ERW	5	4.5 - 9.0	555	40	15.0	133.0	13.0	520	72	1,500
D206ERW	5	4.5 - 9.0	547	40	24.0	83.0	8.0	470	73	1,500
D207ERW	5	4.5 - 9.0	597	40	±5.0	±200.0	±20.0	±560	67	1,500
D208ERW	5	4.5 - 9.0	555	40	±12.0	±83.0	±8.0	±330	72	1,500
D209ERW	5	4.5 - 9.0	547	40	±15.0	±66.0	±7.0	±270	73	1,500
D211ERW	12	9.0 - 18.0	191	20	3.3	500.0	50.0	2,200	72	700
D212ERW	12	9.0 - 18.0	216	20	5.0	400.0	40.0	1,000	77	700
D213ERW	12	9.0 - 18.0	211	20	9.0	222.0	22.0	820	79	700
D214ERW	12	9.0 - 18.0	206	20	12.0	166.0	16.0	680	81	700
D215ERW	12	9.0 - 18.0	208	20	15.0	133.0	13.0	520	80	700
D216ERW	12	9.0 - 18.0	208	20	24.0	83.0	8.0	470	80	700
D217ERW	12	9.0 - 18.0	222	20	±5.0	±200.0	±20.0	±560	75	700
D218ERW	12	9.0 - 18.0	214	20	±12.0	±83.0	±8.0	±330	78	700
D219ERW	12	9.0 - 18.0	214	20	±15.0	±66.0	±7.0	±270	78	700
D221ERW	24	18.0 - 36.0	96	10	3.3	500.0	50.0	2,200	72	350
D222ERW	24	18.0 - 36.0	108	10	5.0	400.0	40.0	1,000	77	350
D223ERW	24	18.0 - 36.0	105	10	9.0	222.0	22.0	820	79	350
D224ERW	24	18.0 - 36.0	103	10	12.0	166.0	16.0	680	81	350
D225ERW	24	18.0 - 36.0	104	10	15.0	133.0	13.0	520	80	350
D226ERW	24	18.0 - 36.0	104	10	24.0	83.0	8.0	470	80	350
D227ERW	24	18.0 - 36.0	109	10	±5.0	±200.0	±20.0	±560	76	350
D228ERW	24	18.0 - 36.0	105	10	±12.0	±83.0	±8.0	±330	79	350
D229ERW	24	18.0 - 36.0	107	10	±15.0	±66.0	±7.0	±270	78	350
D231ERW	48	36.0 - 72.0	48	5	3.3	500.0	50.0	2,200	71	135
D232ERW	48	36.0 - 72.0	55	5	5.0	400.0	40.0	1,000	75	135
D233ERW	48	36.0 - 72.0	53	5	9.0	222.0	22.0	820	79	135
D234ERW	48	36.0 - 72.0	52	5	12.0	166.0	16.0	680	80	135
D235ERW	48	36.0 - 72.0	53	5	15.0	133.0	13.0	520	79	135
D236ERW	48	36.0 - 72.0	52	5	24.0	83.0	8.0	470	80	135
D237ERW	48	36.0 - 72.0	55	5	±5.0	±200.0	±20.0	±560	75	135
D238ERW	48	36.0 - 72.0	52	5	±12.0	±83.0	±8.0	±330	80	135
D239ERW	48	36.0 - 72.0	52	5	±15.0	±66.0	±7.0	±270	80	135

**Notes:**

- When measuring output ripple, it is recommended that an external ceramic capacitor (approx. 1 μF to 10 μF) be placed from the +Vout pin to the -Vout pin for single output units and from each output to common for dual output units.
- Operation at no-load will not damage the units, however, they may not meet all specifications. A minimum 10% load is recommended.
- Connection to the control (remote on/off) input must be made as shown in the typical connection diagram below. This input is referenced to the -Vin pin. Input current to the pin (Ic) should be between 5 - 10 mA with a maximum of 20 mA. Exceeding 20 mA could cause damage to the unit. If not used, the pin should be left open. Grounding the pin could damage the unit. The value for R1 can be calculated by the formula at right.  $R_1 = \frac{V_c - V_b - 1}{I_c}$
- These converters are specified for operation without external components (except as noted above for the control input). However, in some applications the addition of input/output components will enhance stability and reduce output ripple. Recommended capacitor values are given in the table at right. Recommended inductor values would be 4.7-120 μH for the input and 2.2-10 μH for the output. Output ripple on single output units may be further enhanced by using the CS terminal (single output units operated at 50% load or below should use this function). A low ESR capacitor is connected between the CS pin and the -Vout pin (the anode of the capacitor is connected to the -Vout pin). Recommended capacitor values are given in the table at right. If not used, the CS pin should be left open.
- It is recommended that a fuse be used on the input of a power supply for protection. See the Model Selection table above for the correct rating.

Vin	Input Capacitor	Vout	Output Capacitor
5 VDC	100 μF	5 VDC	47 μF
12 VDC	100 μF	12 VDC	47 μF
24 VDC	10 μF	15 VDC	47 μF
48 VDC	10 μF		

  

Output Voltage					
3.3V	5V	9V	12V	15V	24V
CS	47 μF - 100 μF	22 μF - 47 μF			

## Derating Curve

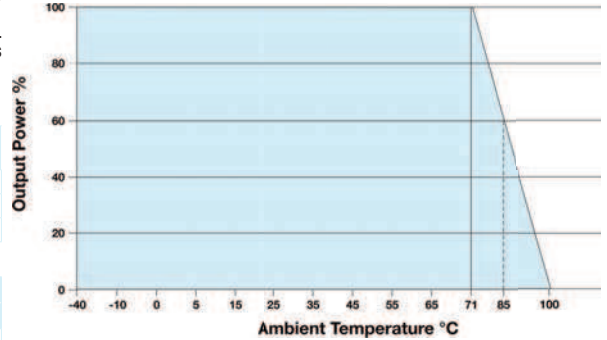

## Typical Connection

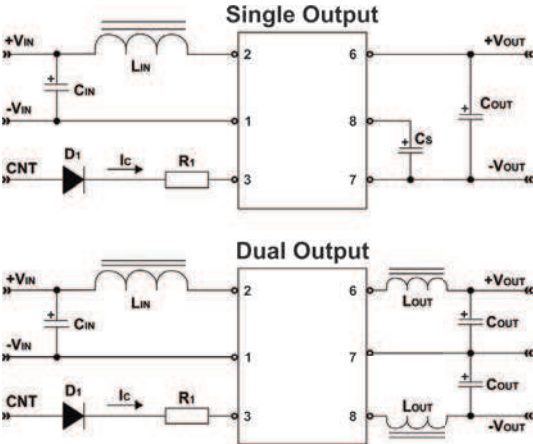

## Pin Connections

Pin	Single	Dual
1	-Vin	-Vin
2	+Vin	+Vin
3	Remote ON/OFF	
5	NC	NC
6	+Vout	+Vout
7	-Vout	Common
8	CS	-Vout

NC = No Connection

## Mechanical Dimensions

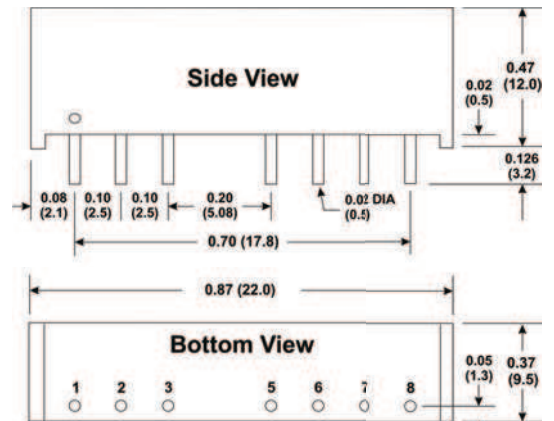

**Mechanical Notes:**

- All dimensions are typical in inches (mm)
- Tolerance x.xx = ±0.01 (±0.25)



**MicroPower Direct**  
**We Power Your Success - For Less!**