

# MPM-10 Series

## Compact, 10W PC Mount Single, Dual & Dual ISO Out AC/DC Power Supplies



### Key Features:

- 10W Output Power
- Universal 85-264 VAC Input
- EN 60950 Approved (UL)
- Single, Dual & Dual Iso Outputs
- Meets EN 55022 B
- >200 kHour MTBF
- Compact PC Mount Case



### MicroPower Direct

292 Page Street  
Suite D  
Stoughton, MA 02072  
USA

T: (781) 344-8226  
F: (781) 344-8481  
E: sales@micropowerdirect.com  
W: www.micropowerdirect.com



### Electrical Specifications

Specifications typical @ +25°C, 230 VAC input voltage & rated output current, unless otherwise noted. Specifications subject to change without notice.

#### Input

Parameter	Conditions	Min.	Typ.	Max.	Units
Input Voltage Range		85		264	VAC
		120		370	VDC
Input Frequency		47		63	Hz
Input Current	See Model Selection Guide				
Inrush Current	115 VAC		10.0		A Pk
	230 VAC		20.0		
EMI	Meets CISPR Pub. 22/FCC Class B				
Safety Ground Leakage Current	115 VAC			0.1	mA
	230 VAC			0.3	

#### Output

Parameter	Conditions	Min.	Typ.	Max.	Units
Output Voltage	See Model Selection Guide				
Output Current	See Model Selection Guide				
Output Voltage Accuracy			±2.0		%
Line Regulation			±0.5		
Load Regulation, See Note 1	See Model Selection Guide				
Ripple & Noise (20 MHz)			50		mV Pk - Pk
	115 VAC		20		
Hold-Up Time	230 VAC		80		mSec
Temperature Coefficient			±0.02		%/°C
Short Circuit Protection	Continuous (Autorecovery)				
Overload Protection	Typ. 110% of Output Power				

#### General

Parameter	Conditions	Min.	Typ.	Max.	Units
Isolation Voltage	Input to Output	3,000			VAC
	Input to Ground	1,500			
	Output to Ground	500			
EMI/RFI	Conducted	EN 55022 Level B			
EMC Compliance	Electrostatic Discharge (ESD)	EN 61000-4-2 Level 3 6kV/8kV			
	RF Field Susceptibility	EN61000-4-3			
	Electrical Fast Transients/Bursts On Mains	EN 61000-4-4 Level 3 2 kV			
	Surge	EN 61000-4-5 Level 3 1kV/2 kV			
Switching Frequency			150		kHz

#### Environmental

Parameter	Conditions	Min.	Typ.	Max.	Units
Operating Temperature Range	Ambient	-25	+25	+70	°C
	Case			+90	°C
Storage Temperature Range		-25		+105	°C
Cooling	Free Air Convection (See Derating Curve)				
Humidity	RH, Non-condensing			85	%

#### Physical

Case Size	2.16 x 1.77 x 0.81 Inches (55.0 x 45.0 x 20.5 mm)				
Case Material	Non-Conductive Black Plastic (UL94-V0)				
Weight	4.23 Oz (120g)				

#### Reliability Specifications

Parameter	Conditions	Min.	Typ.	Max.	Units
MTBF	MIL HDBK 217F, 25°C, Gnd Benign	200			kHours
Safety Standards	UL 60950, EN 60950				
Safety Approvals	UL, cUL; File No. E245422				

[www.micropowerdirect.com](http://www.micropowerdirect.com)

Model Number	Input		Output 1 (Vout 1)				Output 2 (Vout 2)				Output 3 (Vout 3)			Efficiency (% Typ)
	Current (A)		Voltage (VDC)	Current (A)		Over Volt. Protection (VDC)	Voltage (VDC)	Current (A)		Over Volt. Protection (VDC)	Voltage (VDC)	Current (A)		
	115 VAC	230 VAC		Rated	Load Reg.			Rated	Load Reg.			Rated	Load Reg.	
MPM-10S-03	0.23	0.12	3.3	2.00	±1.0%	6.5								70
MPM-10S-05	0.23	0.12	5.0	2.00	±1.0%	6.5								76
MPM-10S-09	0.23	0.12	9.0	1.10	±1.0%	12.0								78
MPM-10S-12	0.23	0.12	12.0	0.90	±1.0%	20.0								80
MPM-10S-15	0.23	0.12	15.0	0.70	±1.0%	20.0								81
MPM-10S-24	0.23	0.12	24.0	0.45	±1.0%	30.0								82
MPM-10D-05	0.23	0.12	+5.0	+1.00	±2.0%	6.5	-5.0	-1.00	±2.0%	6.5				76
MPM-10D-12	0.23	0.12	+12.0	+0.45	±2.0%	20.0	-12.0	-0.45	±2.0%	20.0				80
MPM-10D-15	0.23	0.12	+15.0	+0.35	±2.0%	20.0	-15.0	-0.35	±2.0%	20.0				81
MPM-10D-24	0.23	0.12	+24.0	+0.20	±2.0%	30.0	-24.0	-0.20	±2.0%	30.0				84
MPM-10ID-0505	0.23	0.12	5.0	1.80	±3.0%	6.5	5.0	0.20	±5.0%	6.5				75
MPM-10ID-0512	0.23	0.12	5.0	1.50	±3.0%	6.5	12.0	0.20	±5.0%	20.0				79
MPM-10ID-0515	0.23	0.12	5.0	1.40	±3.0%	6.5	15.0	0.20	±5.0%	20.0				79
MPM-10ID-0524	0.23	0.12	5.0	1.00	±3.0%	6.5	24.0	0.20	±5.0%	30.0				81

Notes:

- Load regulation is measured for an output change of 10% to 90% at nominal input line. For multiple output models, the loads are balanced.
- The **MPM-10** series is specified for operation over the wide operating temperature range of -25°C to +55°C without derating. For operation over +55°C, derate the power linearly by 3.75%/°C from +55°C to +70°C.
- Model numbers **MPM-10ID-05xx** are dual isolated units (Dual ISO). The outputs on these models are isolated from each other.
- It is recommended that a fuse be used on the input of a power supply for protection. For the **MPM-10** series, a 2A/250 VAC slow blow should be used.

Typical Connection

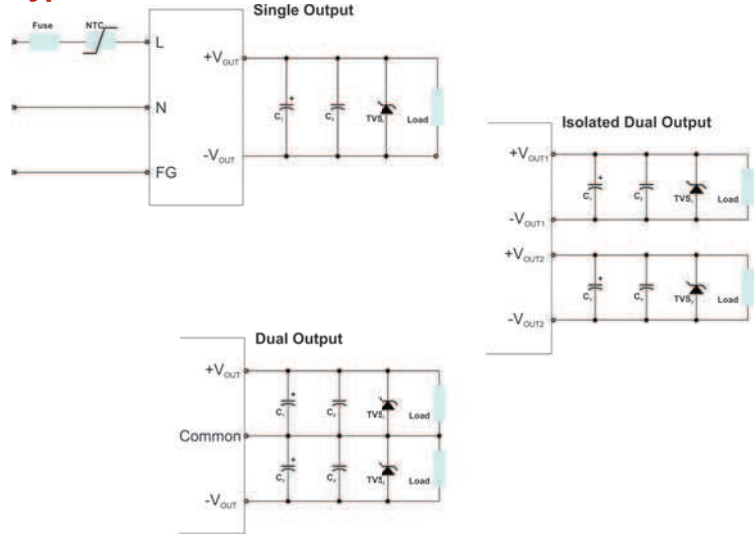

Mechanical Dimensions

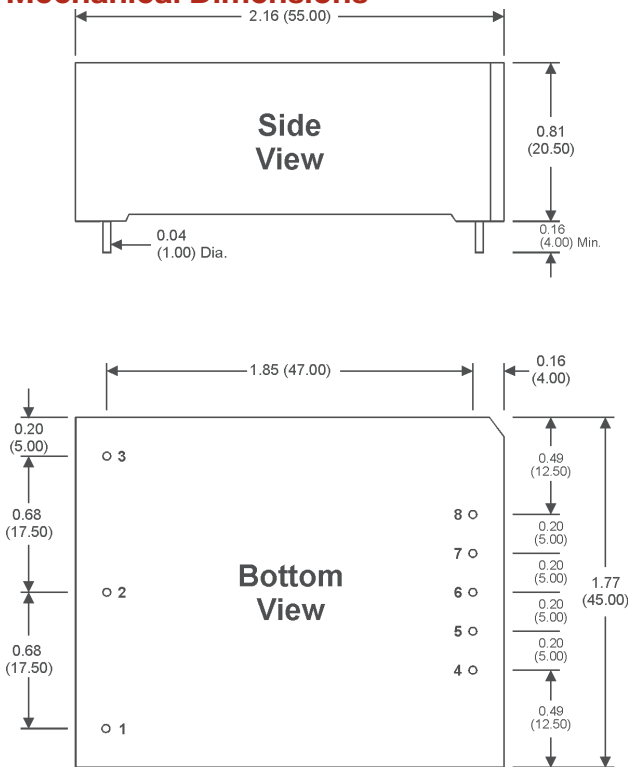

Notes:

- All dimensions are typical in inches (mm)
- Tolerance x.xx = ±0.01 (±0.25)

Typical Component Values

Vout	C1, C3	C2, C4	Fuse	TVS
3.3	330 ~ 1,000 µF/16V	0.1 µF/50V Ceramic	2A/ 250 VAC Slow Blow	P6KE6.8A
5.0	330 ~ 1,000 µF/16V			P6KE6.8A
12.0	220 µF/25V			P6KE16A
15.0	220 µF/25V			P6KE20A
24.0	120 µF/35V			P6KE33A

Notes:

- C1 and C3 are high frequency, low resistance electrolytic capacitors. Refer to the suppliers specifications for capacitance/current ratings.
- Voltage derating on all capacitors should be 80% or higher.
- C2 and C4 eliminate high frequency noise.
- The TVS is recommended to protect load circuitry in the event of a module failure.

Pin Connections

Pin	Single	Dual	Dual ISO
1	AC-Ground	AC-Ground	AC-Ground
2	AC-Neutral	AC-Neutral	AC-Neutral
3	AC-Line	AC-Line	AC-Line
4	-Vo 1	-Vo 2	-Vo 1
5	No Pin	No Pin	+Vo 1
6	No Pin	Common	No Pin
7	No Pin	No Pin	-Vo 2
8	+Vo 1	+Vo 1	+Vo 2



**MicroPower Direct**  
 We Power Your Success - For Less!