

SRS10A-12 Series

Miniature, Non-isolated 10A Output, Switching POL Regulators



Key Features:

- 10A Output Current
- Efficiency to 95%
- EN 60950 Approved (UL)
- Compact SIP Case
- Wide Input Range
- Short Circuit Protected
- Thermal Shutdown
- Remote On/Off Control
- Industry Standard Footprint



MicroPower Direct

292 Page Street
Suite D
Stoughton, MA 02072
USA

T: (781) 344-8226

F: (781) 344-8481

E: sales@micropowerdirect.com

W: www.micropowerdirect.com



Electrical Specifications

Specifications typical @ +25°C, nominal input voltage & rated output current, unless otherwise noted. Specifications subject to change without notice.

Input

Parameter	Conditions	Min.	Typ.	Max.	Units
Input Voltage Range		8.3	12.0	14.0	VDC
Under Voltage Lockout, Power Up	Turn On Voltage Threshold		8.0		VDC
	Turn Off Voltage Threshold		7.7		
	Lockout Hysteresis Voltage		0.3		
Maximum Input Current	$I_{OUT} = 100\%$, $V_{IN} = 0$ to 14 VDC			7.0	A
Off Input Current	Input Idle Current			10	mA
Input Filter	Capacitive				
Input Reflected Ripple Current	See Note 1		200		mA P-P

Output

Parameter	Conditions	Min.	Typ.	Max.	Units
Output Voltage/Current	See Model Selection Guide				
Output Voltage Tolerance				±1.5	%
Line Regulation	$V_{IN} = \text{Min to Max}$			±0.2	%
Load Regulation	$I_{OUT} = 0\%$ to 100%			±0.5	%
Ripple & Noise (20 MHz)	See Note 2			50	mV P-P
				20	mV RMS
Transient Recovery Time, See Note 3	50% Load Change			200	µSec
Temperature Coefficient				±0.03	%/°C
Short Circuit Protection	Continuous (Hiccup Mode)				
Over Temperature Protection	See Note 4		120		°C
Overload Protection	See Note 5		170		%

General

Parameter	Conditions	Min.	Typ.	Max.	Units
Isolation Voltage	Not Isolated				
Switching Frequency	Fixed		300		kHz

Remote On/Off, See Note 6

Parameter	Conditions	Min.	Typ.	Max.	Units
Unit On	Logic High			Open or V_{IN}	
Unit Off	Logic Low	0.0		0.4	VDC
On/Off Current	$V_{ON}/V_{OFF} = 0.0V$			1	mA

Environmental

Parameter	Conditions	Min.	Typ.	Max.	Units
Operating Temperature Range	Ambient	-40	+25	+85	°C
Storage Temperature Range		-55		+125	°C
Cooling	Free Air Convection (See Derating Curves)				
Humidity	RH, Non-condensing			93	%

Physical

Parameter	Conditions	Min.	Typ.	Max.	Units
Size	2.0 x 0.51 x 0.32 Inches (50.8 x 13.0 x 8.3 mm)				
Weight					0.325 Oz (10.0g)

Reliability Specifications

Parameter	Conditions	Min.	Typ.	Max.	Units
MTBF	MIL HDBK 217F, 25°C, Gnd Benign		980		kHours
Safety Standards	UL 60950, EN 60950				

www.micropowerdirect.com

Model Number	Input		Output		Efficiency (% Typ)	Capacitive Load (µF Max)	Fuse Rating Slow-Blow (A)		
	Voltage (VDC) Range	Current (mA) Full-Load No-Load	Voltage (VDC)	Current (A, Max) Current (A, Min)					
SRS10A-12-5.0	8.3 - 14.0	2,956	40	0.75	10.0	0.0	8,000	10	82
		2,956	50	1.20					86
		2,956	50	1.50					89
		2,956	60	1.80					90
		2,956	60	2.00					91
		2,956	60	2.50					92
		2,956	70	3.30					93
		2,956	70	5.00					95

Notes:

1. Measured over a bandwidth of 5 Hz to 20 MHz using a 1 µH inductor.
2. Output ripple is measured at 20 MHz bandwidth using a 1.0 µF ceramic capacitor and a 10 µF tantalum capacitor connected in parallel as close to the output terminals as possible.
3. Transient recovery is measured to within a 200 mV error band for a 50% load change.
4. These units include a non-latching over temperature protection circuit. If the temperature exceeds approximately 120°C at the monitored "hot spot", the unit will be shut down. When the temperature decreases, the unit will automatically restart. See page 3 for temperature measurement information.
5. These units will provide up to 150% of rated current. In the event of an over current fault, the unit will go into hiccup mode until the fault is removed.
6. Standard units feature an active high remote control input. See the note and diagram at right.
7. These units do not include an internal fuse. It is recommended that an external slow-blow fuse be used with a rating as shown in the table above.

Remote On/Off

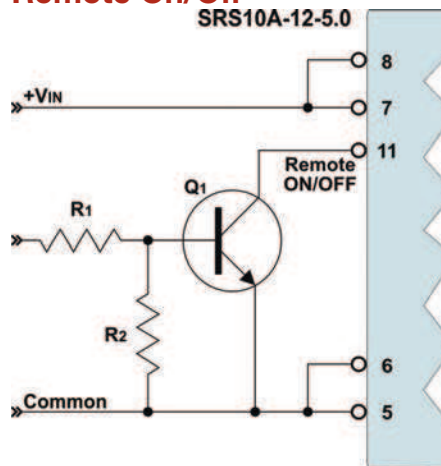

These units include an active high On/OFF control input. The unit is "ON" if the input to the control pin (pin 11) is high; or if the pin is left open (or floating). The signal level of the control input is referenced to ground. A recommended drive circuit for the control pin is shown at left. The resistors R1 & R2 have been added to help reduce possible false triggering of the control input due to leakage currents.

Units are available with an active low control input. With this input, the unit will remain off if the control input remains above 2.8 VDC. For more information on the active low option, contact the factory.

Typical Connection

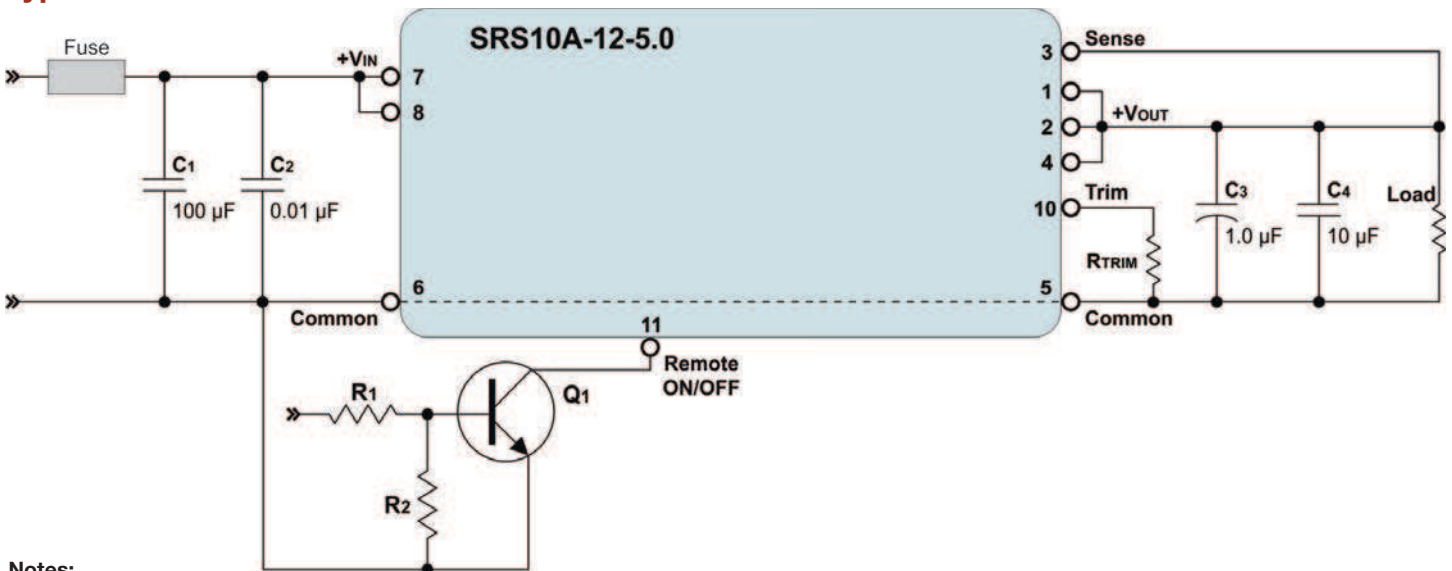

Notes:

Fuse: SRS10A-12 regulators do not include an internal fuse. For safety and protection, an external slow-blow fuse should be placed in the input (+VIN) line. A 10A fuse is recommended.

Input Filter: The unit must be connected to a low AC impedance source, and to avoid loop stability issues, the source inductance should also be low. To significantly reduce ripple caused by the switching action of the POL, the SRS10A-12 includes onboard filtering. However, adding input capacitors C1 and C2 will further reduce ripple currents (C1) and high frequency noise spikes (C2). These capacitors should be placed as close to the input pins as possible (see board layout at right). It is recommended that low ESR (<100 mΩ) and low ESL ceramic capacitors be used. Recommended values are:

C1	C2
33 µF to 250 µF	0.01 µF

Remote ON/OFF: See note above

Output Trim: See note on page 4

Remote Sense: The remote sense helps regulate the output voltage at the point of load by minimizing the effects of distribution losses. The voltage between the sense pin (Pin 3) and the point of load should not exceed 500 mV. When using the remote sense function, the output voltage level may rise. Care must be taken not to exceed the maximum rated output power of the regulator. When not in use, the remote sense pin should be tied to the output pin of the regulator.

Output Filter: Output filtering is not required, but may be used to further reduce output ripple & noise; or to adjust the transient response time of the unit. Care must be taken not to exceed 8,000 µF, the maximum value of output capacitance the unit is rated for. The values given in the connection diagram are typical for light filtering.



Derating Curves

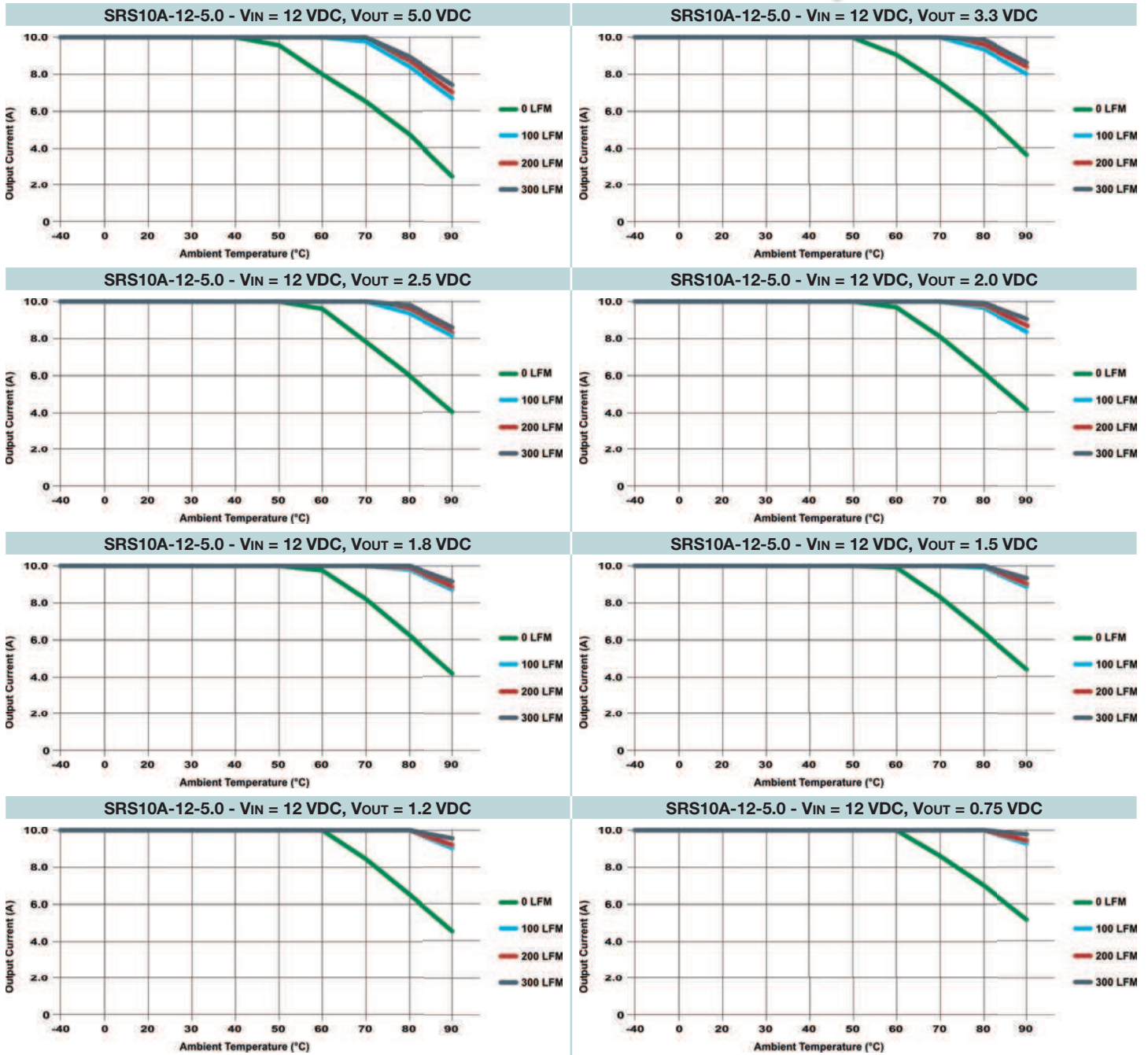

Temperature Measurement

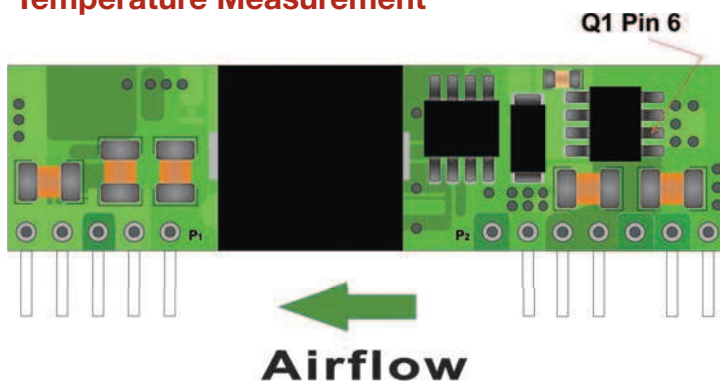

These switching regulators may be used in a wide variety of thermal environments, but must be properly cooled to ensure long reliable operation. The derating curves shown above are approximations of the ambient temperature and airflow required to maintain the switching regulator temperature below its maximum rating.

Airflow should move parallel to the long axis of the unit, as shown at left. Proper cooling can be verified by measuring the temperature at pin six of Q₁ (as shown at left). The thermocouple should be mounted approximately 0.5 in. off the unit board. The temperature at this location should not exceed 110°C.

Suggested Board Layout

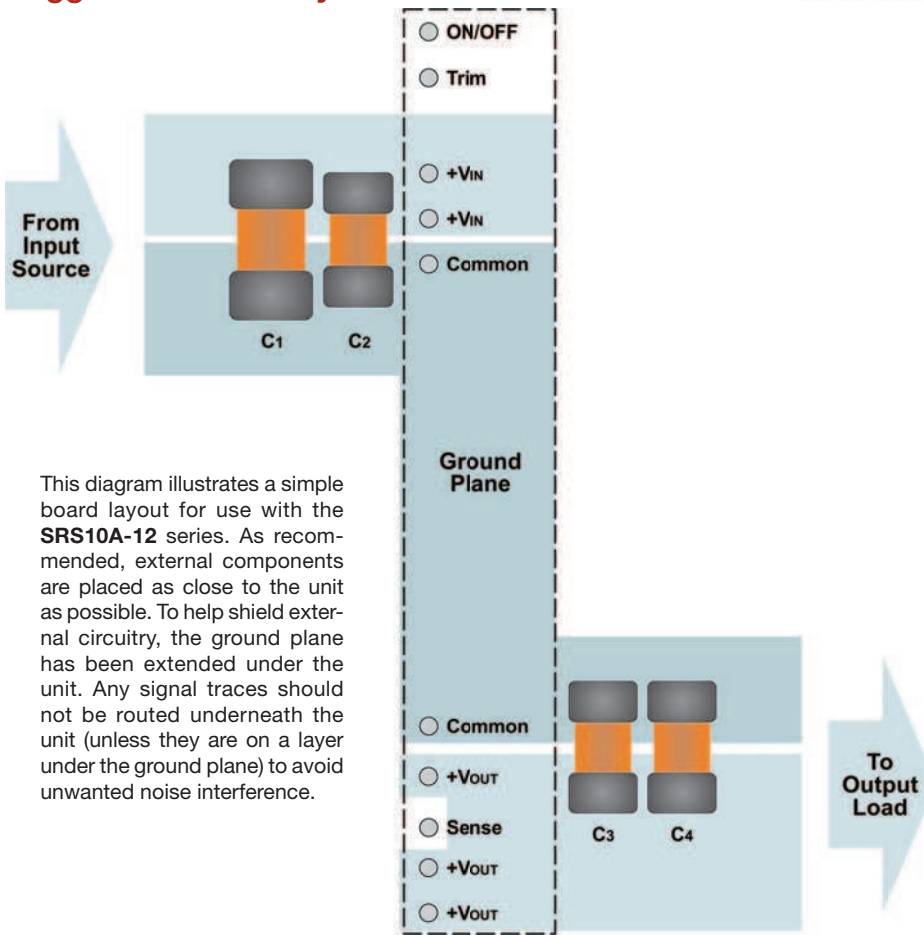

This diagram illustrates a simple board layout for use with the **SRS10A-12** series. As recommended, external components are placed as close to the unit as possible. To help shield external circuitry, the ground plane has been extended under the unit. Any signal traces should not be routed underneath the unit (unless they are on a layer under the ground plane) to avoid unwanted noise interference.

Output Voltage Trim

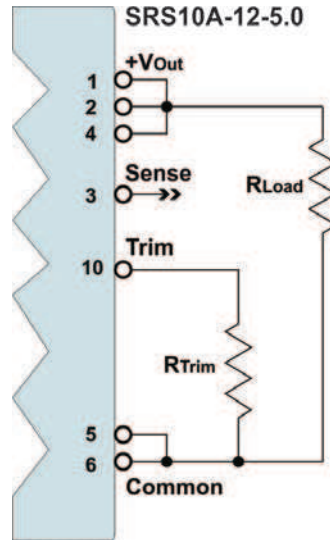

The output voltage level of the **SRS10A-12** series is adjustable over a wide range by the simple addition of an external resistor. This trim resistor is connected between the circuit common and the trim input (pin 10), as shown in the diagram above.

SRS10A-12-5.0	
VOUT (VDC)	RTRIM (kΩ)
0.75	Open
1.20	22.33
1.50	13.00
1.80	9.00
2.00	7.40
2.50	5.00
3.30	3.12
5.00	1.47

The required resistor value for various output levels is given in the table above. To calculate the correct value for a different output level, the formula is:

$$R_{TRIM} = \left(\frac{10,500}{V_{OUT} - 0.75} - 1,000 \right)$$

Where: RTRIM = The external trim resistor
VOUT = The desired output voltage

If a trim resistor is not connected, the output goes to 0.75 VDC.

Pin Connections

Pin	Description	Pin	Description
1	+V Output	6	Common
2	Sense	7	+V Input
3	+V Output	8	+V Input
4	+V Output	10	Trim
5	Common	11	Remote On/Off

Mechanical Dimensions

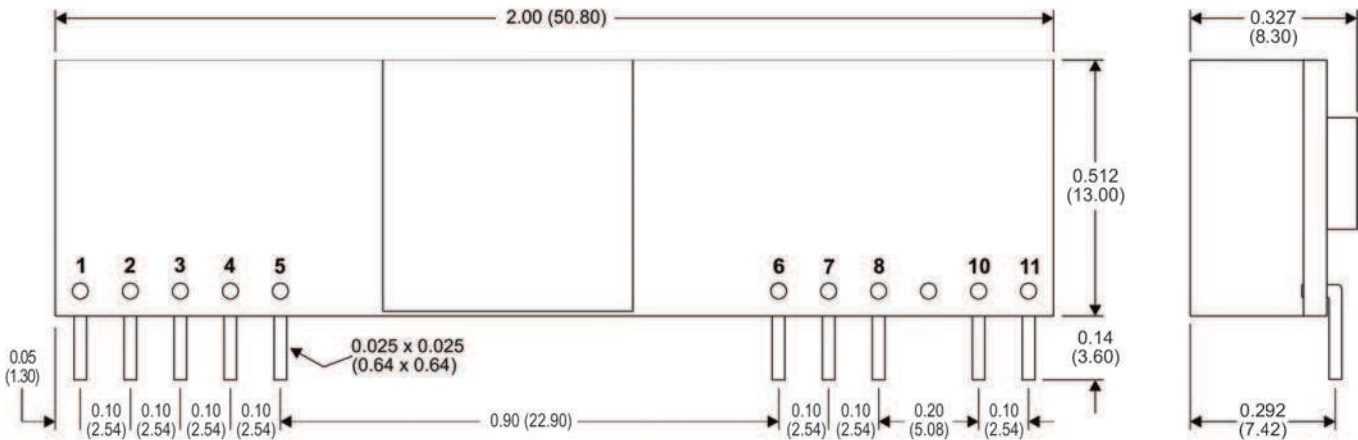

MicroPower Direct
We Power Your Success - For Less!

292 Page Street Ste D Stoughton, MA 02072 • TEL: (781) 344-8226 • FAX: (781) 344-8481 • E-Mail: sales@micropowerdirect.com

Notes:

- All dimensions are typical in inches (mm)
- Tolerance x.xx = ±0.02 (±0.50)