



1A Low Dropout Positive Voltage Regulators

Features

- Dropout Guaranteed <1.3V at Full Load Current
- Fast Transient Response
- Voltage Reference Initial Accuracy of 2%
- Built-In Thermal Shutdown
- Available in RoHS-compliant halogen-free D-Pak, SOT-223, and SOT-89 surface-mount packages.

Applications

- Graphic and Sound Card Applications
- Low-voltage IC Supply Applications
- PC Clock Supply Voltage

Description

The APU1117-33-HF-3 is a low-dropout, three-terminal fixed output regulator with minimum output current capability of 1A, specifically designed to provide a well-regulated supply for low-voltage IC applications such as VGA, sound and DVD cards.

The APU1117-33-HF-3 is specifically designed to be stable with low-cost aluminum capacitors, and is guaranteed to have a drop-out voltage less than 1.3V at full load, making it ideal to provide well-regulated outputs of 3.3V from input supplies from 4.75V to 7V.

Typical Application

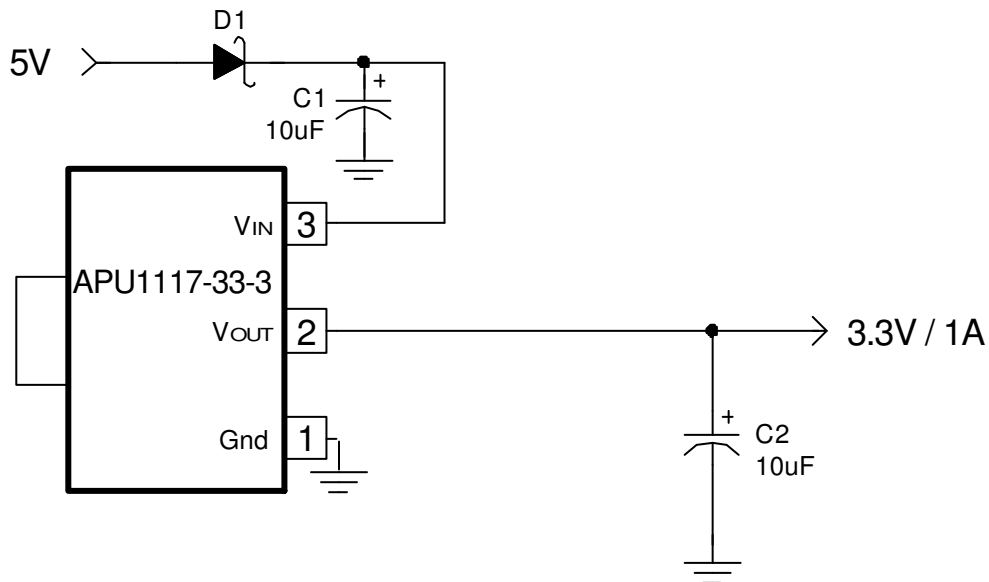
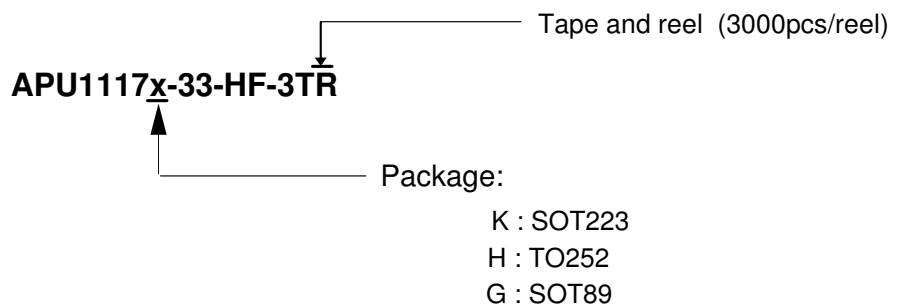

Figure 1 - Typical application of APU1117-33-3 in a 5V to 3.3V regulator.

Ordering information



Example: APU1117K-33-HF-3TR 3.3V output voltage in RoHS-compliant halogen-free SOT-223, shipped on tape and reel, 3000pcs/reel



Absolute Maximum Ratings

Input Voltage (V_{IN})	7V
Power Dissipation	Internally Limited
Storage Temperature Range	-65°C To 150°C
Operating Junction Temperature Range	0°C To 150°C
Thermal Resistance, Junction-Ambient: TO-252	70°C/W for 0.5" square pad
SOT-89	100°C/W for minimum pad
SOT-223.....	90°C/W for 0.4" square pad

Pin Configurations

2-PIN PLASTIC TO-252 (H)

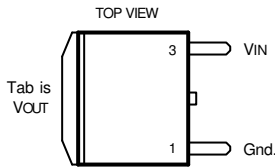

3-PIN PLASTIC SOT-89 (G)

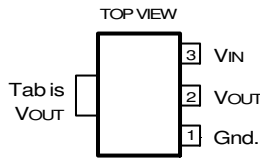

3-PIN PLASTIC SOT-223 (K)

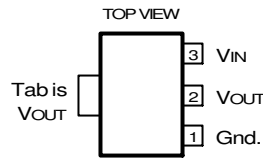

Electrical Specifications

Unless otherwise specified, these specifications apply over $V_{IN}=5V$, $C_{IN}=1\mu F$, $C_{OUT}=10\mu F$, and $T_J=0$ to $125^\circ C$. Typical values refer to $T_J=25^\circ C$.

PARAMETER	SYM	TEST CONDITION	MIN	TYP	MAX	UNITS
Output Voltage	V_o	$I_o=10mA$, $T_J=25^\circ C$	3.235	3.300	3.365	V
Line Regulation		$I_o=10mA$, $4.75V < V_{IN} < 7V$			7	mV
Load Regulation (Note 1)		$10mA < I_o < 1A$			1	%
Dropout Voltage (Note 2)	ΔV_o	Note 2, $I_o=1A$		1.1	1.3	V
Current Limit		$\Delta V_o=100mV$	1.1			A
Thermal Regulation		30ms Pulse, $I_o=1A$		0.01	0.02	%/W
Ripple Rejection		$f=120Hz$, $C_o=25\mu F$ Tantalum, $I_o=0.5A$	60	70		dB
Temperature Stability		$I_o=10mA$		0.5		%
Long Term Stability		$T_J=125^\circ C$, 1000 hours		0.3	1	%
RMS Output Noise		$T_J=25^\circ C$, $10Hz < f < 10kHz$		0.003		% V_o

Note 1: Low duty-cycle pulse testing with Kelvin connections is required in order to maintain accurate data.

Note 2: Dropout voltage is defined as the minimum differential voltage between V_{IN} and V_{OUT} required to maintain regulation at V_{OUT} . It is measured when the output voltage drops 1% below its nominal value.

THIS PRODUCT IS SENSITIVE TO ELECTROSTATIC DISCHARGE, PLEASE HANDLE WITH CAUTION.

USE OF THIS PRODUCT AS A CRITICAL COMPONENT IN LIFE SUPPORT OR OTHER SIMILAR SYSTEMS IS NOT AUTHORIZED.

APEC DOES NOT ASSUME ANY LIABILITY ARISING OUT OF THE APPLICATION OR USE OF ANY PRODUCT OR CIRCUIT DESCRIBED HEREIN; NEITHER DOES IT CONVEY ANY LICENSE UNDER ITS PATENT RIGHTS, NOR THE RIGHTS OF OTHERS.

APEC RESERVES THE RIGHT TO MAKE CHANGES WITHOUT FURTHER NOTICE TO ANY PRODUCTS HEREIN TO IMPROVE RELIABILITY, FUNCTION OR DESIGN.



Pin Descriptions

PIN #	PIN SYMBOL	PIN DESCRIPTION
1	Gnd.	Ground pin. This pin must be connected to ground plane using a low-inductance short connection.
2	V _{OUT}	The output of the regulator. A capacitor of at least 10 μ F must be connected from this pin to ground to ensure stability.
3	V _{IN}	The input pin of the regulator. Typically a large storage capacitor is connected from this pin to ground to ensure that the input voltage does not sag below the minimum dropout voltage during the load transient response. This pin must always be 1.3V higher than V _{OUT} in order for the device to regulate properly.

Block Diagram

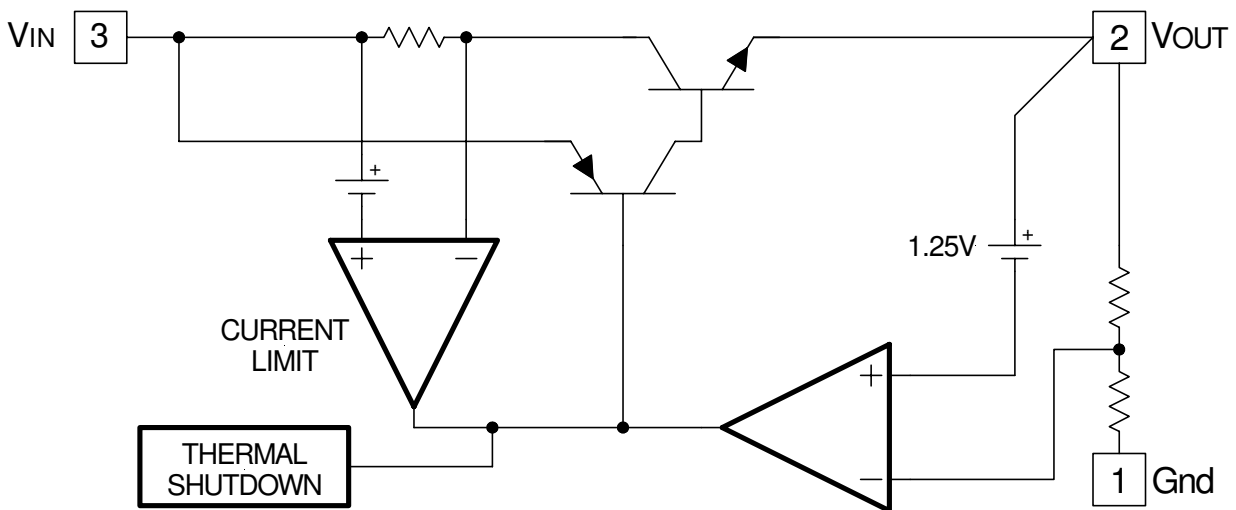
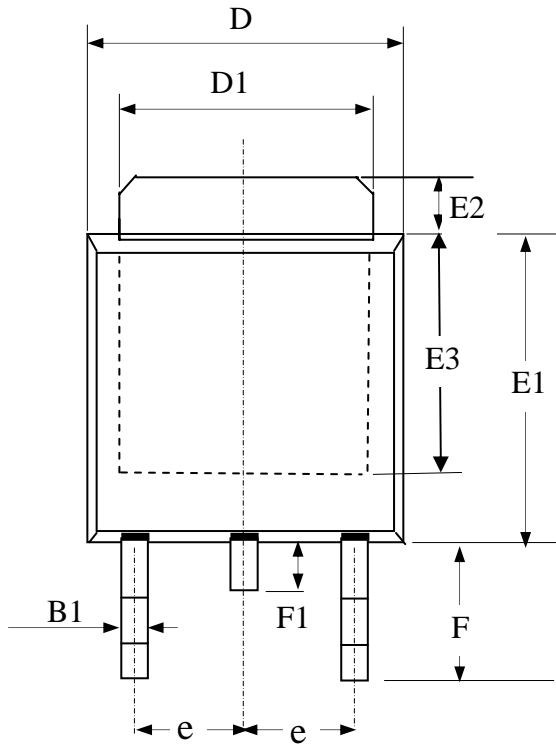

Figure 2 - Simplified block diagram of the APU1117-33-3.



Package Dimensions: TO-252



SYMBOLS	Millimeters		
	MIN	NOM	MAX
A2	1.80	2.30	2.80
A3	0.40	0.50	0.60
B1	0.40	0.70	1.00
D	6.00	6.50	7.00
D1	4.80	5.35	5.90
E3	3.50	4.00	4.50
F	2.20	2.63	3.05
F1	0.50	0.85	1.20
E1	5.10	5.70	6.30
E2	0.50	1.10	1.80
e	--	2.30	--
C	0.35	0.50	0.65

1. All dimensions are in millimeters.
2. Dimensions do not include lead dimensions.

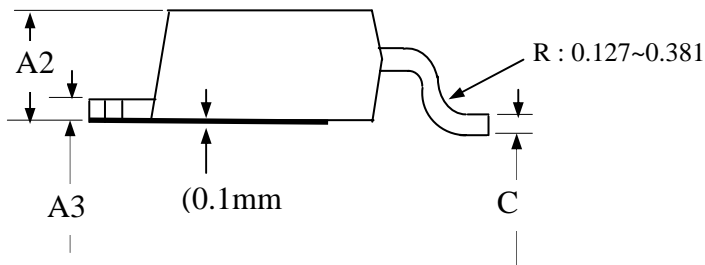

Marking Information

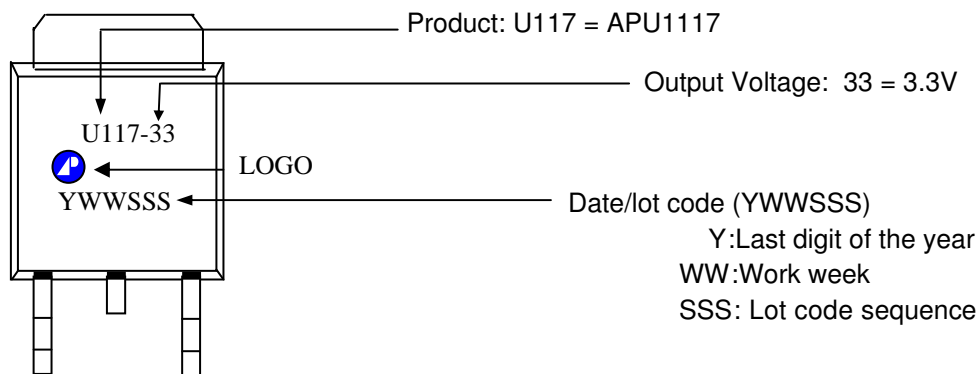



Package Dimensions: SOT-223

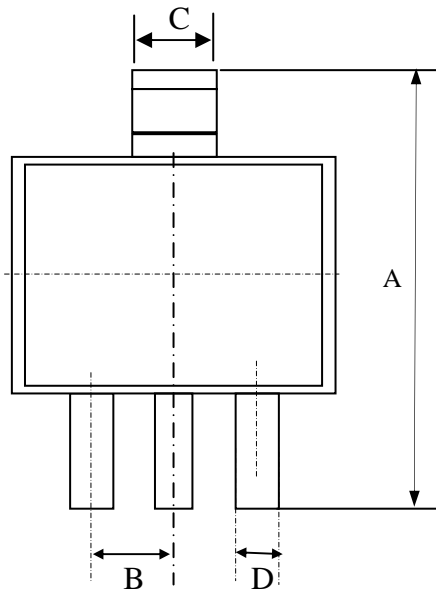

SYMBOLS	Millimeters		
	MIN	NOM	MAX
A	6.70	7.00	7.30
B	---	2.30	---
C	2.90	3.00	3.10
D	0.60	0.70	0.80
G	0.25	0.30	0.35
E	6.30	6.50	6.70
F	1.40	1.60	1.80
K	0.02	0.06	0.10

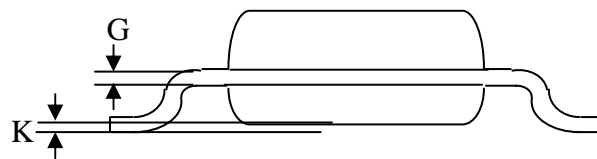
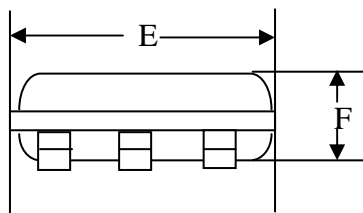

1. All dimensions are in millimeters.
2. Dimensions do not include mold protrusions.

Marking Information

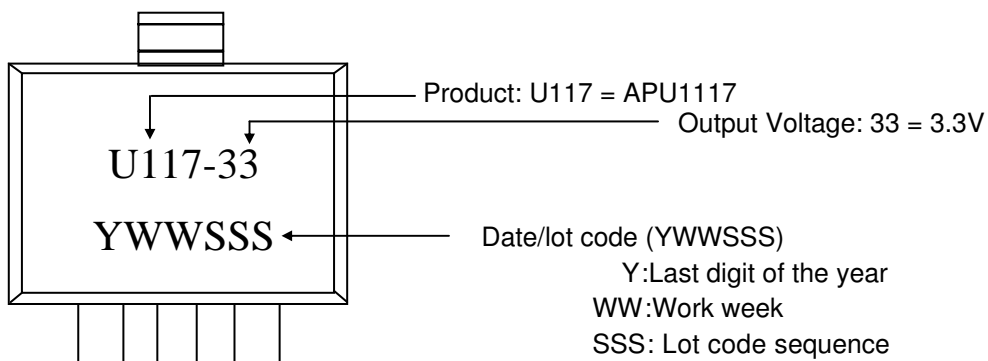



Package Dimensions: SOT-89

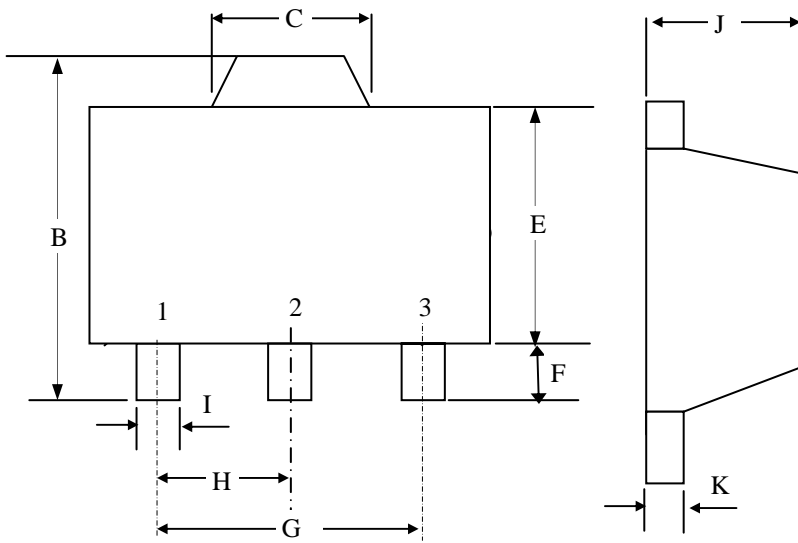

SYMBOLS	Millimeters		
	MIN	NOM	MAX
A	4.40	-	4.60
B	4.05	-	4.25
C	1.40	-	1.75
E	2.40	-	2.60
F	0.89	-	1.20
I	0.35	-	0.55
H	----	1.50	----
G	----	3.00	----
J	1.40	-	1.60
K	0.35	-	0.43

1. All dimensions are in millimeters.
2. Dimensions do not include mold protrusions.

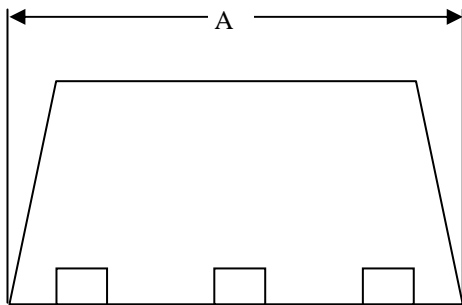

Marking Information

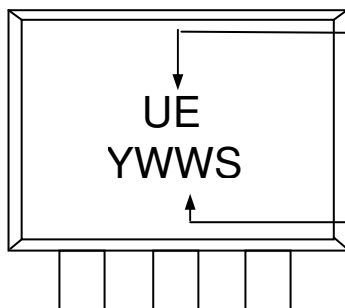

Product: UE = APU1117G-33-3

Date/lot code (YWWS)

Y: Last digit of the year
 WW: Work week
 S: Lot code sequence